

## Abgaskompensator mit Anschweißenden

### Typ 200

### Typ 201 (mit Innenleitrohr)

Der Typ 200 ist ein mehrlagiger Abgaskompensator mit Anschweißenden. Er ist speziell konzipiert für den Betrieb in Anlagen mit geringen Betriebsdrücken (bis maximal 1 barg).

Dieser Kompensator lässt sowohl axiale, laterale wie auch angulare Bewegungen zu.

#### Beschreibung

Die angegebenen Bewegungen gelten nicht in Kombination. Der Gesamtnutzungsfaktor darf 1 nicht überschreiten. Bei 100%iger Ausnutzung der axialen Bewegung ist keine laterale Bewegung mehr zulässig.

Neben den aufgeführten Standardbaulängen kann die Baulänge speziell auf Ihre Bedürfnisse angepasst gefertigt werden. Dieser Kompensator kann auch in anderen Werkstoffen (siehe Seite 179) gefertigt werden.

Die angegebenen Bewegungen stellen die einzelnen Maximalwerte dar. Zur Ermittlung kombinierter Bewegungsmöglichkeiten verwenden Sie bitte das Bewegungsschaubild auf Seite 10.

#### Ausführung

Zur Realisierung größerer Kompensatorenbaulängen sind Varianten mit Zwischenrohr aus Balgmaterial (Ausführung 3) bzw. aus einem eingeschweißten Zwischenrohr (Ausführung 2) erhältlich.

#### Anwendung

Abgaskompensatoren kommen in einer Vielzahl von Anwendungen zum Einsatz, z. B. Turbinenauslassstutzen, Aggregaten, Generatoren, Schiffsantriebe, Erstausrüster-Motoren und Hilfssysteme.

Abgaskompensatoren können für jede spezielle Anforderung und Anwendung kundenspezifisch angefertigt werden.

#### Vorteile

- Gasdicht und beständig gegen Korrosion und hohen Temperaturen
- Nimmt Schwingungen auf
- Die leichte Bauweise in Kombination mit sehr niedrigen Federraten verringern die auf die Rohrleitungs-komponenten wirksamen Lasten.
- Platzsparend

### Type 200

### Type 201 (with internal sleeve)



Type 200 is a multi-layer exhaust expansion joint with weld ends. It is designed specifically for operation in installations with low operating pressures (up to maximum 1 barg).

This expansion joint allows axial, lateral and angular movements.

#### Description

The specified movements do not apply to combinations. The total utilisation factor must not exceed 1. With 100% utilisation of the axial movement, no further lateral movement is permissible.

In addition to the given standard lengths, other lengths are available to meet specific requirements. This expansion joint can also be produced in other materials (see page 179).

The specified movements represent the individual maximum values. For determining combined movements refer to the movement diagram on page 10.

#### Versions

For longer expansion joint lengths, versions are available with an intermediate pipe of bellows material (version 3) or a welded intermediate pipe (version 2).

#### Applications

Exhaust expansion joints are used in a wide range of applications, e.g. turbine exhausts, apparatus, generators, marine propulsion, OEM motors and auxiliary systems.

Exhaust expansion joints can be made to suit all specific customer requirements and applications.

#### Advantages

- Gas-tight and resistant to corrosion and high temperatures
- Absorb vibrations
- Lightweight design combined with very low spring rates reduce loads exerted on pipeline components

## Abgaskompensator Exhaust expansion mit Anschweißenden joint with weld ends

### Typ 200

### Typ 201 (mit Innenleitrohr)

### Typ 200

### Typ 201 (with internal sleeve)

#### Einsatzbeispiele

Flüssige und gasförmige Medien im Niederdruckbetrieb, z. B. Abgasanlagen im Schiffbau, Biogasanlagen, Blockheizkraftwerke etc.

#### Standardmäßiger Aufbau

Mehrlagiger Wellrohrbalg aus 1.4541 mit Anschweißenden aus 1.0345/P235 (HI) bzw. ab DN 500 1.0425/P265 (HII). Ab einer Anschweißendendicke von 3,5 mm ist dieses montagefertig gefast.

#### Zulässige Betriebsdaten (Standard)

1 barg / 550 °C / 1000 Lastwechsel  
Höhere Drücke auf Anfrage.

#### Zubehör

Innenleitrohr, Außenschutzrohr

#### Hinweis

Bei Verwendung von Leitrohren vermindert sich die Möglichkeit der Aufnahme der lateralen oder angularen Bewegungen um min. 90 %. Die Ausführung 3 ist nicht vakuumfest. Bitte beachten Sie bei Ihrer Planung die Medienverträglichkeit der zu verwendenden Kompensatorenmaterialien.

#### Application examples

Liquid and gaseous media in low pressure operation, e.g. exhaust systems in shipbuilding, biogas plants, block-type thermal power stations, etc.

#### Standard design

Multi-layer corrugated tube bellows of 1.4541 with weld ends of 1.0345/P235 (HI) and from DN 500 1.0425/P265 (HII). From a weld end thickness of 3.5 mm, these parts are bevelled ready for installation.

#### Permissible operating data

1 barg / 550 °C / 1000 load cycles  
Higher pressures on request.

#### Accessories

Internal sleeve, external protective sleeve

#### Note

When using internal sleeves, the possibility to compensate for lateral or angular movements reduces by minimum 90 %. Version 3 is not vacuum-tight. To be noted is that the media compatibility of the expansion joint material to be used should be taken into account in the planning phase.

## Ausführungsvarianten / Versions

#### Ausführung 1 / Model 1



#### Ausführung 2 / Model 2



#### Ausführung 3 / Model 3



## Ausführung 1

### Model 1

Druckstufe 1 barg (PN 1)

Design pressure 1 barg (PN 1)

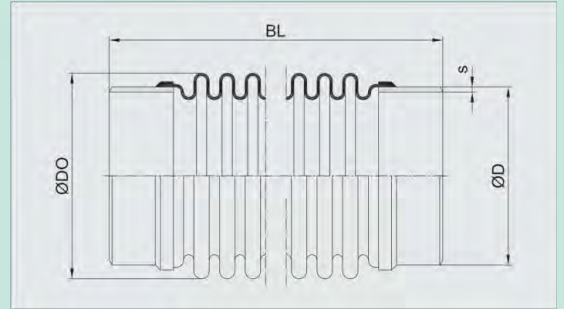

DN	Länge Length	Balg Bellows			Anschweißenden Weld ends			Bewegungsaufnahm Movement			rstellkraftrate Springrate			Gewicht Weight	Artikel Article
		BL mm	ØDO cm <sup>2</sup>	WF* mm	ØD mm	s mm	mm	axial 2δN mm	lateral 2λN mm	angular 2αN e <sub>o</sub> /deg.	axial Cδ <sub>Ve</sub> N/mm	lateral Cλ N/mm	angular Cα Nn/deg.		
50	215	69	28	60,3	2,9	30	18	50	73	41	0,6	0,7	200-01-030-0050		
50	280	69	28	60,3	2,9	49	50	50	45	9,6	0,4	0,8	200-01-049-0050		
65	205	87	46	76,1	2,9	34	15	50	64	77	0,9	0,8	200-01-034-0065		
65	270	87	46	76,1	2,9	56	42	50	63	26	0,9	1,3	200-01-056-0065		
80	165	114	79	88,9	3,2	34	8	38	64	308	1,4	1,2	200-01-034-0080		
80	210	114	79	88,9	3,2	56	22	50	38	64	0,9	1,4	200-01-056-0080		
80	270	114	79	88,9	3,2	85	51	50	26	18	0,6	1,5	200-01-085-0080		
100	165	145	131	114,3	3,6	49	9	43	40	382	1,5	1,7	200-01-049-0100		
100	200	144	130	114,3	3,6	70	19	50	29	113	1,1	1,7	200-01-070-0100		
100	275	144	129	114,3	3,6	119	59	50	27	33	1,0	2,6	200-01-119-0100		
125	165	171	188	139,7	4,0	49	7	36	46	640	2,4	2,2	200-01-049-0125		
125	215	171	187	139,7	4,0	84	23	50	42	174	2,2	3,2	200-01-084-0125		
125	315	172	186	139,7	4,0	125	65	50	47	51	2,4	4,9	200-01-125-0125		
150	175	204	271	168,3	4,5	54	7	33	51	716	3,8	2,6	200-01-054-0150		
150	250	204	271	168,3	4,5	109	31	50	26	90	1,9	3,4	200-01-109-0150		
150	405	203	266	168,3	4,5	158	94	50	48	35	3,5	6,8	200-01-158-0150		
200	190	257	442	219,1	6,3	76	10	36	40	713	4,9	4,5	200-01-076-0200		
200	275	259	441	219,1	6,3	120	32	50	62	255	7,6	7,3	200-01-120-0200		
200	310	259	444	219,1	6,3	149	48	50	32	96	4,0	7,1	200-01-149-0200		
250	190	309	663	273,0	6,3	67	7	26	59	1450	11,0	6,1	200-01-067-0250		
250	310	314	673	273,0	6,3	144	38	50	39	173	7,3	8,8	200-01-144-0250		
250	400	313	667	273,0	6,3	194	73	50	47	96	8,6	14,3	200-01-194-0250		
300	190	365	927	323,9	7,1	69	6	23	70	2540	18,0	9,1	200-01-069-0300		
300	245	370	943	323,9	7,1	121	18	40	21	290	5,3	8,5	200-01-121-0300		
300	415	365	923	323,9	7,1	207	70	50	48	126	13,0	17,6	200-01-207-0300		
350	190	404	1132	355,6	6,3	54	3	16	39	2800	13,0	8,5	200-01-054-0350		
350	265	402	1126	355,6	6,3	121	17	36	22	377	6,9	9,8	200-01-121-0350		



350	415	400	1113	355,6	6,3	219	64	50	45	173	14,0	19,7	200-01-219-0350
400	230	461	1478	406,4	6,3	90	8	23	59	2280	25,0	12,5	200-01-090-0400
400	305	461	1478	406,4	6,3	151	23	39	36	494	15,0	14,5	200-01-151-0400
400	410	457	1459	406,4	6,3	229	56	50	44	241	18,0	22,7	200-01-229-0400
450	230	511	1842	457,0	6,3	88	7	20	69	3360	36,0	14,0	200-01-088-0450
450	305	511	1842	457,0	6,3	152	21	35	42	720	22,0	16,3	200-01-152-0450
450	410	510	1832	457,0	6,3	229	50	50	44	299	23,0	22,1	200-01-229-0450
500	240	566	2263	508,0	6,3	99	8	21	72	3750	46,0	15,7	200-01-099-0500
500	340	564	2254	508,0	6,3	188	28	40	45	692	28,0	18,2	200-01-188-0500
500	445	564	2248	508,0	6,3	266	59	50	47	321	29,0	28,3	200-01-266-0500
600	240	679	3257	610,0	4,0	101	6	17	129	9550	116,0	13,8	200-01-101-0600
600	330	679	3257	610,0	4,0	177	21	31	74	1790	67,0	20,4	200-01-177-0600
600	450	679	3257	610,0	4,0	279	52	49	47	461	43,0	22,4	200-01-279-0600
700	260	777	4335	711,0	4,0	98	5	15	150	14800	180,0	20,7	200-01-098-0700
700	350	778	4341	711,0	4,0	176	18	27	82	2650	99,0	25,1	200-01-176-0700
700	470	781	4358	711,0	4,0	280	45	43	47	611	56,0	31,8	200-01-280-0700
800	230	886	5654	813,0	4,0	76	2	10	169	38700	265,0	23,7	200-01-076-0800
800	320	886	5654	813,0	4,0	153	11	20	85	4860	133,0	23,7	200-01-153-0800
800	470	884	5640	813,0	4,0	279	39	37	50	851	78,0	36,4	200-01-279-0800
900	230	990	7110	914,0	4,0	75	2	9	173	49900	342,0	21,0	200-01-075-0900
900	320	990	7110	914,0	4,0	151	10	18	87	6270	171,0	32,3	200-01-151-0900
900	440	990	7110	914,0	4,0	253	29	30	52	1360	103,0	35,3	200-01-253-0900
1000	230	1096	8749	1016,0	4,0	75	2	8	165	59200	399,0	29,6	200-01-075-1000
1000	290	1098	8765	1016,0	4,0	127	6	13	92	11900	224,0	35,9	200-01-127-1000
1000	440	1093	8724	1016,0	4,0	252	26	27	55	1770	133,0	39,2	200-01-252-1000

\*WF = wirksame Fläche / effective area





1700	460	1763	23368	1720,0	4,0	223	12	14	105	11200	677,0	69,8	200-01-223-1700
1800	285	1864	26142	1820,0	4,0	78	1	4	343	351700	2490,0	48,3	200-01-078-1800
1800	345	1864	26199	1820,0	4,0	130	3	8	206	78300	1500,0	56,7	200-01-130-1800
1800	460	1864	26142	1820,0	4,0	224	12	14	115	13700	830,0	73,9	200-01-224-1800
1900	285	1962	29117	1920,0	4,0	74	1	4	390	426200	3150,0	50,8	200-01-074-1900
1900	345	1963	29132	1920,0	4,0	126	3	7	225	92700	1820,0	59,8	200-01-126-1900
1900	465	1963	29132	1920,0	4,0	228	11	13	125	16200	1020,0	77,9	200-01-228-1900
2000	285	2061	32204	2020,0	4,0	72	1	4	425	503800	3800,0	56,7	200-01-072-2000
2000	345	2061	32204	2020,0	4,0	121	3	6	255	112200	2280,0	62,9	200-01-121-2000
2000	465	2061	32204	2020,0	4,0	217	10	12	142	19700	1270,0	82,0	200-01-217-2000
2100	285	2160	35449	2120,0	4,0	77	1	4	359	496100	3540,0	60,7	200-01-077-2100
2100	345	2161	35466	2120,0	4,0	125	3	6	208	104300	2050,0	72,6	200-01-125-2100
2100	465	2162	35483	2120,0	4,0	225	10	12	111	17300	1100,0	96,5	200-01-225-2100
2200	285	2260	38865	2220,0	4,0	77	1	3	375	568300	4050,0	63,6	200-01-077-2200
2200	345	2260	38865	2220,0	4,0	126	3	6	225	124300	2430,0	76,0	200-01-126-2200
2200	470	2260	38865	2220,0	4,0	234	10	12	125	21000	1350,0	102,0	200-01-234-2200

\*WF = wirksame Fläche / effective area

Weitere Abmessungen und Werkstoffe auf Anfrage. /  
Other dimensions and materials on request.

## Ausführung 2

### Model 2

Druckstufe 1 barg (PN 1)  
Design pressure 1 barg (PN 1)

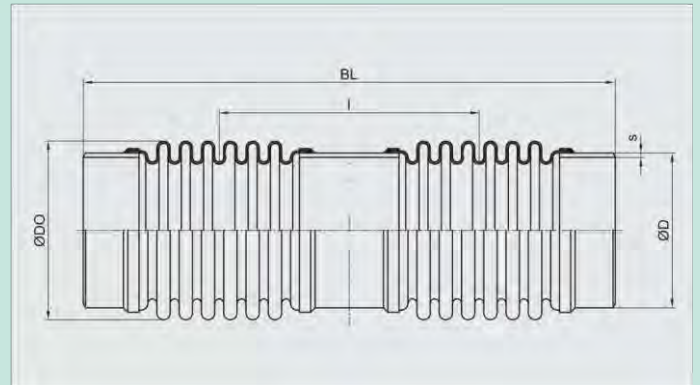

DN	Länge Length	Balg Bellow				Anschweißenden Weld ends			aufnahme Mount		Verstell Sp		Gewicht Weight	Artikel Article
		BL mm	ØDO	WF* cm <sup>2</sup>	mm	I** mm	ØD	s mm	mm	axial	lateral	axial		
									2ΔN mm	2ΔN mm	CΔ N/mm	CΔ N/mm	kg	
50	410	69	28	195	60,3	2,9	60	140	37	1,6	1,3	200-01-060-0050		
65	390	87	46	185	76,1	2,9	69	120	32	2,6	1,5	200-01-069-0065		
80	395	114	79	228	88,9	3,2	68	122	32	3,1	2,8	200-01-064-0080		
100	375	145	131	208	114,3	3,6	99	123	20	3,8	3,8	200-01-092-0100		
125	405	171	188	238	139,7	4,0	99	122	23	4,9	5,4	200-01-094-0125		
150	430	204	271	255	168,3	4,5	109	119	26	6,6	6,7	200-01-101-0150		
200	360	257	442	170	219,1	6,3	152	77	20	19,0	8,3	200-01-135-0200		
250	415	309	663	228	273,0	6,3	134	79	30	23,0	13,9	200-01-122-0250		
300	415	365	927	223	323,9	7,1	167	77	35	41,0	20,0	200-01-149-0300		
350	415	404	1132	222	355,6	6,3	173	57	20	28,0	18,7	200-01-120-0350		
400	455	461	1478	223	406,4	6,3	212	75	30	53,0	24,3	200-01-185-0400		
450	485	511	1842	253	457,0	6,3	201	77	35	61,0	29,4	200-01-184-0450		
500	505	566	2263	262	508,0	6,3	223	79	36	72,0	32,9	200-01-199-0500		
600	570	679	3257	330	610,0	4,0	202	79	65	117,0	32,9	200-01-180-0600		
700	640	777	4335	380	711,0	4,0	197	79	75	138,0	49,7	200-01-177-0700		
800	605	886	5654	283	813,0	4,0	340	77	43	172,0	44,2	200-01-300-0800		
900	625	990	7110	302	914,0	4,0	348	76	44	197,0	62,7	200-01-310-0900		

1000	640	1098	8765	350	1016,0	4,0	323	68	46	201,0	77,7	200-01-252-1000
1100	665	1198	10540	383	1120,0	4,0	235	57	72	326,0	80,6	200-01-211-1100
1200	730	1264	11794	415	1220,0	4,0	223	54	82	356,0	88,0	200-01-212-1200
1300	740	1364	13818	395	1320,0	4,0	265	57	76	419,0	88,6	200-01-259-1300
1400	760	1464	15980	415	1420,0	4,0	264	57	81	472,0	98,3	200-01-259-1400
1500	790	1564	18299	445	1520,0	4,0	263	57	87	504,0	110,0	200-01-260-1500
1600	820	1664	20776	475	1620,0	4,0	262	58	92	535,0	122,0	200-01-257-1600
1700	700	1764	23409	355	1720,0	4,0	261	39	98	1130,0	109,0	200-01-254-1700
1800	720	1864	26199	375	1820,0	4,0	260	39	103	1200,0	119,0	200-01-259-1800
1900	740	1963	29132	395	1920,0	4,0	254	38	113	1320,0	130,0	200-01-251-1900
2000	775	2061	32204	433	2020,0	4,0	242	39	128	1360,0	144,0	200-01-236-2000
2100	715	2161	35466	367	2120,0	4,0	306	33	104	1690,0	150,0	200-01-256-2100
2200	735	2260	38865	387	2220,0	4,0	299	34	113	1810,0	161,0	200-01-260-2200

\*WF = wirksame Fläche / effective area Weitere Abmessungen und Werkstoffe auf Anfrage. / \*\*I = Mittenabstand / center distance request.

Other dimensions and materials on



### Ausführung 3

### Model 3

Druckstufe 1 barg (PN 1)  
Design pressure 1 barg (PN 1)

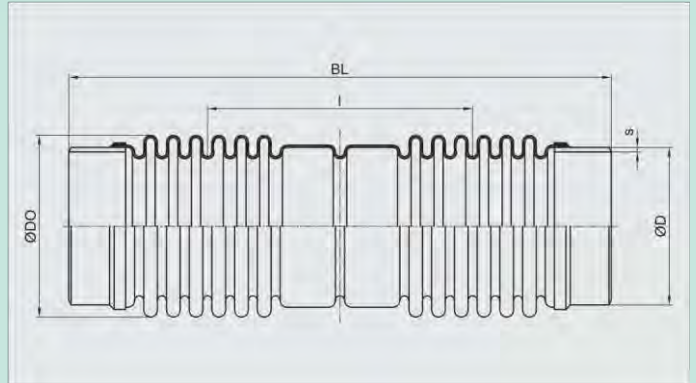

DN	Balg Bellow				Anschweißenden Weld ends			gsaufnahme ement		Verstellkr Spr		Gewicht Weight kg	Artikel Article
	BL mm	ØDO cm <sup>2</sup>	WF* mm	l** mm	ØD mm	s mm	mm	axial 2δN mm	lateral 2λN mm	axial Cδ N/mm	lateral Cλ N/mm		
50	310	69	28	133	60,3	2,9		38	63	57	5,7	0,8	200-01-038-0050
65	315	87	46	149	76,1	2,9		41	62	53	7,3	1,1	200-01-041-0065
80	305	114	79	138	88,9	3,2		68	76	32	9,0	1,5	200-01-068-0080
100	270	145	131	115	114,3	3,6		82	62	24	17,0	2,1	200-01-082-0100
125	275	170	187	120	139,7	4,0		78	51	31	28,0	2,6	200-01-078-0125
150	330	204	271	155	168,3	4,5		109	76	26	21,0	3,7	200-01-109-0150
200	320	258	444	145	219,1	6,3		102	52	49	72,0	6,5	200-01-102-0200
250	320	312	669	145	273,0	6,3		98	41	59	130,0	8,1	200-01-098-0250
300	320	363	923	145	323,9	7,1		95	34	68	208,0	10,3	200-01-095-0300
350	350	401	1121	170	355,6	6,3		96	37	62	171,0	11,8	200-01-096-0350
400	390	458	1464	195	406,4	6,3		125	49	50	137,0	14,5	200-01-125-0400
450	390	509	1830	195	457,0	6,3		125	44	55	190,0	16,3	200-01-125-0450
500	385	560	2238	193	508,0	6,3		112	36	82	352,0	16,9	200-01-112-0500
550	385	609	2676	192	559,0	4,0		104	31	98	495,0	14,9	200-01-104-0550
600	420	672	3211	210	610,0	4,0		137	40	102	529,0	18,4	200-01-137-0600
700	495	781	4358	265	711,0	4,0		151	48	85	377,0	25,1	200-01-151-0700
800	495	883	5634	265	813,0	4,0		151	42	95	544,0	28,7	200-01-151-0800
900	495	985	7072	265	914,0	4,0		151	38	105	755,0	32,3	200-01-151-0900
1000	495	1087	8674	265	1016,0	4,0		151	34	115	1020,0	35,9	200-01-151-1000

1100	515	1191	10476	265	1120,0	4,0	151	31	125	1330,0	41,7	200-01-151-1100
1200	595	1263	11784	314	1220,0	4,0	145	30	113	971,0	49,5	200-01-145-1200
1300	595	1363	13787	314	1320,0	4,0	145	28	122	1230,0	53,6	200-01-145-1300
1400	595	1463	15947	314	1420,0	4,0	145	26	130	1520,0	57,6	200-01-145-1400
1500	595	1563	18264	314	1520,0	4,0	145	24	139	1860,0	61,6	200-01-145-1500
1600	595	1663	20737	314	1620,0	4,0	145	22	148	2250,0	65,7	200-01-145-1600
1700	595	1763	23368	314	1720,0	4,0	145	21	157	2680,0	69,8	200-01-145-1700
1800	595	1863	26156	314	1820,0	4,0	145	20	166	3170,0	73,9	200-01-145-1800
1900	595	1963	29101	314	1920,0	4,0	145	19	174	3710,0	77,9	200-01-145-1900
2000	595	2063	32204	314	2020,0	4,0	145	18	183	4310,0	82,0	200-01-145-2000
2100	595	2163	35463	314	2120,0	4,0	145	17	192	4980,0	86,0	200-01-145-2100
2200	595	2263	38879	314	2220,0	4,0	145	16	201	5710,0	90,1	200-01-145-2200

\*WF = wirksame Fläche / effective area Weitere Abmessungen und Werkstoffe auf Anfrage. / \*\*I = Mittenabstand / center distance Other dimensions and materials on request.

## Abgaskompensator mit drehbaren Losflanschen

### Typ 202

Der Typ 202 ist ein mehrlagiger Abgaskompensator mit drehbaren Losflanschen. Er ist speziell konzipiert für den Betrieb in Anlagen mit geringen Betriebsdrücken (bis max. 1 barg).

Dieser Kompensator lässt sowohl axiale, laterale wie auch angulare Bewegungen zu.

#### Beschreibung

Neben den aufgeführten Standardbaulängen kann die Baulänge speziell auf Ihre Bedürfnisse angepasst gefertigt werden. Dieser Kompensator kann auch in anderen Werkstoffen (siehe Seite 179) gefertigt werden.

Die angegebenen Bewegungen stellen die einzelnen Maximalwerte dar. Zur Ermittlung kombinierter Bewegungsmöglichkeiten verwenden Sie bitte das Bewegungsschaubild auf Seite 10.

#### Ausführung

Zur Realisierung größerer Kompensatorenbaulängen sind Varianten mit Zwischenrohr aus Balgmaterial (Ausführung 3) bzw. aus einem eingeschweißten Zwischenrohr (Ausführung 2) erhältlich.

## Typ 203 (mit Innenleitrohr) Exhaust expansion with loose flanges

### Type 202

### Type 203 (with internal sleeve)

#### Anwendung

Abgaskompensatoren kommen in einer Vielzahl von Anwendungen zum Einsatz, z. B. Turbinenauslassstützen, Aggregaten, Generatoren, Schiffsantriebe, Erstausrüster-Motoren und Hilfssysteme.

Abgaskompensatoren können für jede spezielle Anforderung und Anwendung kundenspezifisch angefertigt werden.

#### Vorteile

- ▣ Gasdicht und beständig gegen Korrosion und hohen Temperaturen
- ▣ Nimmt Schwingungen auf
- ▣ Die leichte Bauweise in Kombination mit sehr niedrigen Federraten verringern die auf die Rohrleitungskomponenten wirksame Lasten.
- ▣ Platzsparend



**Einsatzbeispiele** Flüssige und gasförmige Medien im Niederdruckbetrieb, z. B. Abgasanlagen im Schiffbau, Biogasanlagen, Blockheizkraftwerke etc.

**Standardmäßiger Aufbau** Mehrlagiger Wellrohrbalg aus 1.4541 mit glatten Flanschen aus C-Stahl (roh) gebohrt nach DIN 86044-1. Der Bördel besteht aus umgeformtem Balgmaterial.

**Zulässige Betriebsdaten** (Standard) max. 1,0 barg / 550 °C  
Höhere Drücke auf Anfrage.

**Zubehör** Innenleitrohr, Außenschutzrohr

**Hinweis** Bei Verwendung von Leitrohren vermindert sich die Möglichkeit der Aufnahme der lateralen oder angularen Bewegungen um min. 90 %. Die Ausführung 3 ist nicht vakuumfest. Bitte beachten Sie bei Ihrer Planung die Medienverträglichkeit der zu verwendenden Kompensatormaterialien.

**Application examples** Liquid and gaseous media in low pressure operation, e.g. exhaust systems in shipbuilding, biogas plants, block-type thermal power stations, etc.

**Standard design** Multi-layer corrugated tube bellows of 1.4541 with smooth flanges of carbon steel (raw) drilled according to DIN 86044-1. The collar is made from formed bellows material.

**Permissible operating data** max 1.0 barg / 550 °C  
Higher pressures on request.

**Accessories** Internal sleeve, external protective sleeve

**Note** When using internal sleeves, the possibility to compensate for lateral or angular movements reduces by minimum 90 %. Version 3 is not vacuum-tight. To be noted is that the media compatibility of the expansion joint material to be used should be taken into account in the planning phase.

## Ausführungsvarianten / Versions

**Ausführung 1 / Model 1**



**Ausführung 2 / Model 2**



**Ausführung 3 / Model 3**



## Ausführung 1

### Type 202 Specifications Model 1

Druckstufe 1 barg (PN 1)  
Design pressure 1 barg (PN 1)

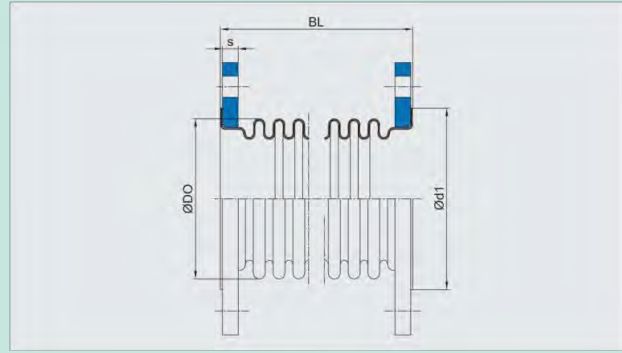

DN	Länge Length	Balg Bellows		Flansch Flanges		Bewegungsaufnahm Movement			Verstellkraftrate Springrate			Gewicht Weight	Artikel Article
		BL mm	ØDO cm <sup>2</sup>	WF* mm	Ød1 mm	s mm	axial 2δN mm	lateral 2λN mm	angular e 2αN %/deg.	angular Cδ N/mm	axial Cλ N/mm		
50	140	69	28	80	20	30	18	50	73	42	0,6	5,8	202-01-030-0050
50	210	69	28	80	20	49	50	50	45	9,2	0,4	5,9	202-01-049-0050
65	130	87	46	98	20	34	15	50	64	79	0,9	6,7	202-01-034-0065
65	190	87	46	98	20	55	39	50	40	18	0,6	6,9	202-01-055-0065
65	235	87	46	98	20	73	68	50	31	8,3	0,4	7,0	202-01-073-0065
80	135	114	79	113	20	34	8	38	64	272	1,4	7,6	202-01-034-0080
80	180	114	79	113	20	56	22	50	38	59	0,9	7,9	202-01-056-0080
80	235	114	79	113	20	85	51	50	26	18	0,6	8,0	202-01-085-0080
100	145	145	131	141	22	49	9	43	40	359	1,5	9,5	202-01-049-0100
100	180	144	130	141	22	70	19	50	29	107	1,1	9,6	202-01-070-0100
100	255	144	129	141	22	119	59	50	27	33	1,0	10,7	202-01-119-0100
125	145	171	188	170	22	49	7	36	46	602	2,4	11,7	202-01-049-0125
125	195	171	187	170	22	84	23	50	42	184	2,2	12,7	202-01-084-0125
125	290	172	186	170	22	125	65	50	47	50	2,4	14,4	202-01-125-0125
150	165	204	271	201	24	54	7	33	51	789	3,8	15,3	202-01-054-0150
150	240	204	271	201	24	109	31	50	26	95	1,9	15,9	202-01-109-0150
150	390	203	266	201	24	158	94	50	48	35	3,5	19,3	202-01-158-0150
200	155	257	442	252	16	76	10	36	40	713	4,9	11,4	202-01-076-0200
200	225	256	440	252	16	130	32	50	24	132	2,9	12,4	202-01-130-0200
200	275	259	444	252	16	149	48	50	32	98	4,0	13,8	202-01-149-0200

250	155	309	663	306	16	67	7	26	59	1520	11,0	13,6	202-01-067-0250
250	275	314	673	306	16	144	38	50	39	178	7,3	16,6	202-01-144-0250
250	370	313	667	305	16	194	73	50	47	96	8,6	22,1	202-01-194-0250
300	170	365	927	357	16	77	7	25	70	2440	18,0	19,6	202-01-077-0300
300	220	370	943	357	16	118	18	39	21	295	5,3	19,6	202-01-118-0300
300	385	365	923	356	16	207	70	50	48	124	13,0	28,1	202-01-207-0300
350	135	404	1132	391	16	54	3	16	39	2800	13,0	23,1	202-01-054-0350
350	210	402	1126	391	16	118	16	35	22	383	6,9	24,8	202-01-118-0350
350	365	400	1113	390	16	219	64	50	45	170	14,0	34,0	202-01-219-0350
400	185	461	1478	442	16	90	8	23	59	2280	25,0	27,8	202-01-090-0400
400	260	461	1478	442	16	151	23	39	36	494	15,0	29,8	202-01-151-0400
400	365	457	1459	441	16	226	56	50	44	243	18,0	38,0	202-01-226-0400
450	185	511	1842	493	16	91	7	21	69	3330	36,0	32,0	202-01-091-0450
450	260	511	1842	493	16	152	21	35	42	720	22,0	34,3	202-01-152-0450
450	365	510	1832	492	16	223	49	50	44	303	23,0	43,5	202-01-223-0450
500	210	566	2263	544	16	108	8	23	72	3600	46,0	34,7	202-01-108-0500
500	305	564	2254	544	16	184	27	39	45	698	28,0	37,2	202-01-184-0500
500	415	564	2248	543	16	270	59	50	47	320	29,0	47,3	202-01-270-0500
600	250	679	3257	643	20	101	6	17	129	9320	116,0	54,2	202-01-101-0600
600	340	679	3257	643	20	177	21	31	74	1740	67,0	58,0	202-01-177-0600
600	460	679	3257	643	20	279	52	49	47	455	43,0	63,0	202-01-279-0600
700	230	777	4335	745	20	98	5	15	150	14100	180,0	62,3	202-01-098-0700
700	320	778	4341	745	20	176	18	27	82	2590	99,0	66,7	202-01-176-0700
700	460	781	4358	745	20	283	45	43	47	608	56,0	73,4	202-01-283-0700
800	200	886	5654	847	20	80	3	10	169	38200	265,0	71,0	202-01-080-0800
800	290	886	5654	847	20	156	12	21	85	4810	133,0	76,0	202-01-156-0800
800	440	884	5640	847	20	282	40	38	50	847	78,0	83,7	202-01-282-0800
900	220	990	7110	949	20	79	2	9	173	49100	342,0	76,3	202-01-079-0900
900	305	990	7110	949	20	144	9	17	87	6400	171,0	81,9	202-01-144-0900

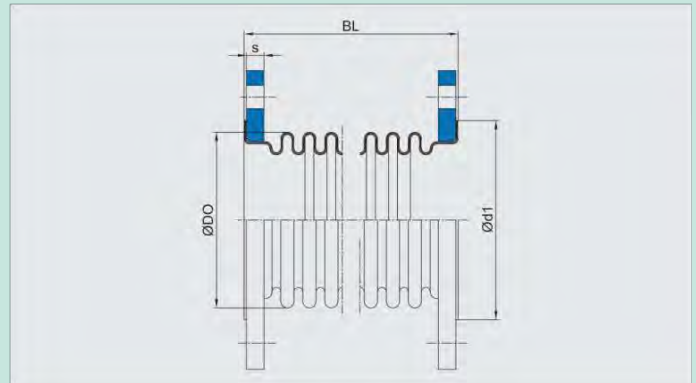

900	425	990	7110	949	20	247	28	29	52	1380	103,0	93,4	202-01-247-0900
-----	-----	-----	------	-----	----	-----	----	----	----	------	-------	------	-----------------

\*WF = wirksame Fläche / effective area

Weitere Abmessungen und Werkstoffe auf Anfrage. /  
Other dimensions and materials on request.

## Ausführung 1

### Model 1

#### Druckstufe 1 barg (PN 1)

#### Design pressure 1 barg (PN 1)

DN	Länge Length	Balg Bellow		Flansch Flanges		wegungsaufnah Movement lateral			erstellkrafttrat Springrate			Gewicht Weight	Artikel Article	
		BL mm	ØDO cm <sup>2</sup>	WF* mm	Ød1 mm	s mm	axial	angular		Cδ N/mm	Cλ N/mm			Cα Nm/deg.
							2ΔN mm	2αN °/deg.	γularaxiallateral					
1000	215	1096	8749	1051	20	71	2	7	165	60400	399,0	84,1	202-01-071-1000	
1000	275	1098	8765	1051	20	120	6	13	92	12100	224,0	93,5	202-01-120-1000	
1000	425	1093	8724	1051	20	246	25	26	55	1790	133,0	104,0	202-01-246-1000	
1100	225	1198	10540	1155	20	95	3	9	144	35600	421,0	96,0	202-01-095-1100	
1100	315	1194	10503	1155	20	170	11	16	95	7630	278,0	103,0	202-01-170-1100	
1100	435	1197	10531	1155	20	274	28	27	55	1750	159,0	114,0	202-01-274-1100	
1200	195	1264	11794	1255	20	101	3	9	163	44200	533,0	104,0	202-01-101-1200	
1200	285	1264	11813	1255	20	178	11	16	101	8860	329,0	112,0	202-01-178-1200	

1200	435	1259	11765	1255	20	286	30	26	71	2040	232,0	124,0	202-01-286-1200
1300	165	1366	13818	1355	20	75	1	6	218	122800	835,0	108,0	202-01-075-1300
1300	225	1364	13818	1355	20	127	5	10	151	30600	580,0	112,0	202-01-127-1300
1300	345	1364	13797	1355	20	227	16	19	78	4880	299,0	125,0	202-01-227-1300
1400	165	1466	15980	1455	20	75	1	6	234	152400	1040,0	116,0	202-01-075-1400
1400	225	1464	15980	1455	20	127	4	10	162	38000	719,0	121,0	202-01-127-1400
1400	345	1464	15958	1455	20	227	15	18	84	6050	371,0	134,0	202-01-227-1400
1500	165	1565	18287	1555	20	75	1	5	259	192400	1320,0	124,0	202-01-075-1500
1500	225	1564	18299	1555	20	127	4	9	173	46400	879,0	129,0	202-01-127-1500
1500	345	1564	18275	1555	20	227	14	17	90	7400	453,0	143,0	202-01-227-1500
1600	165	1664	20750	1655	20	75	1	5	285	239600	1650,0	132,0	202-01-075-1600
1600	225	1664	20776	1655	20	127	4	8	184	56000	1070,0	137,0	202-01-127-1600
1600	345	1664	20750	1655	20	227	13	16	95	8930	547,0	152,0	202-01-227-1600
1700	165	1763	23368	1755	20	76	1	5	313	298000	2030,0	140,0	202-01-076-1700
1700	225	1764	23409	1755	20	127	4	8	195	66900	1270,0	145,0	202-01-127-1700
1700	345	1763	23368	1755	20	228	13	15	105	11100	677,0	161,0	202-01-228-1700
1800	165	1864	26142	1855	20	76	1	4	343	363900	2490,0	145,0	202-01-076-1800
1800	225	1864	26199	1855	20	127	3	7	206	79100	1500,0	153,0	202-01-127-1800
1800	345	1864	26142	1855	20	229	12	14	115	13600	830,0	170,0	202-01-229-1800
1900	165	1962	29117	1955	20	74	1	4	390	448500	3150,0	152,0	202-01-074-1900
1900	225	1963	29132	1955	20	126	3	7	225	95100	1820,0	161,0	202-01-126-1900
1900	345	1963	29132	1955	20	228	11	13	125	16400	1020,0	179,0	202-01-228-1900
2000	165	2061	32204	2055	20	72	1	4	425	529400	3800,0	163,0	202-01-072-2000
2000	225	2061	32204	2055	20	121	3	6	255	115000	2280,0	170,0	202-01-121-2000
2000	344	2061	32204	2055	20	144	0	0	142	16500	1270,0	189,0	202-01-144-2000
2100	170	2160	35449	2155	20	80	1	4	359	485600	3540,0	172,0	202-01-080-2100
2100	230	2161	35466	2155	20	131	3	7	208	102500	2040,0	184,0	202-01-131-2100
2100	350	2162	35483	2155	20	231	10	12	111	17200	1100,0	208,0	202-01-231-2100
2200	170	2260	38865	2255	20	80	1	4	375	556200	4050,0	180,0	202-01-080-2200

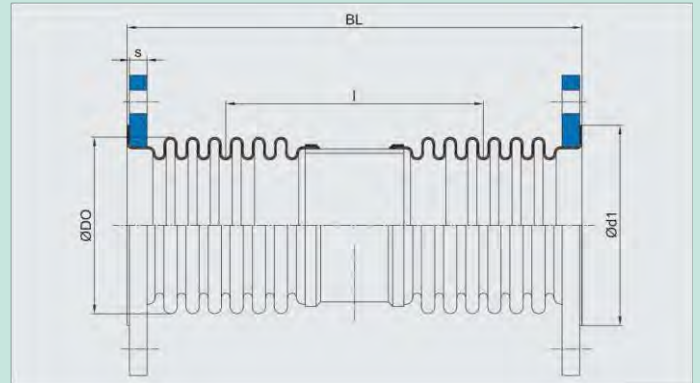

2200	230	2260	38865	2255	20	131	3	6	225	121600	2430,0	192,0	202-01-131-2200
2200	350	2260	38865	2255	20	229	10	11	125	21200	1350,0	217,0	202-01-229-2200

\*WF = wirksame Fläche / effective area

Weitere Abmessungen und Werkstoffe auf Anfrage. /  
Other dimensions and materials on request.

## Ausführung 2

### Model 2

#### Druckstufe 1 barg (PN 1)

#### Design pressure 1 barg (PN 1)

DN	Länge Length	Balg Bellows				Flansch Flanges			saufnahme mount		Verstell Sp		Gewicht Weight	Artikel Article
		BL mm	ØDO mm	WF* cm <sup>2</sup>	mm	l** mm	Ød1 mm	s mm	mm	axial 2δN mm	lateral 2λN mm	axial Cδ N/mm		
50	335	69	28	194	80	20	60	140	37	1,6	6,4	202-01-060-0050		
65	315	87	46	184	98	20	69	120	32	2,6	7,5	202-01-069-0065		





80	360	114	79	239	113	20	68	122	32	3,1	9,3	202-01-064-0080
100	355	145	131	225	141	22	99	123	20	3,8	11,4	202-01-092-0100
125	385	171	188	255	170	22	99	122	23	4,9	14,7	202-01-094-0125
150	420	204	271	276	201	24	109	119	26	6,6	19,4	202-01-101-0150
200	325	257	442	186	252	16	152	77	20	19,0	15,2	202-01-135-0200
250	385	309	663	246	306	16	134	79	30	23,0	21,7	202-01-122-0250
300	395	365	927	245	357	16	167	77	35	41,0	30,4	202-01-153-0300
350	365	404	1132	241	391	16	173	57	20	28,0	33,3	202-01-126-0350
400	410	461	1478	243	442	16	212	75	30	53,0	39,7	202-01-187-0400
450	440	511	1842	274	493	16	201	77	35	61,0	47,4	202-01-184-0450
500	475	566	2263	291	544	16	223	79	36	72,0	49,4	202-01-199-0500
600	580	679	3257	374	643	20	202	79	65	117,0	76,2	202-01-180-0600
700	610	777	4335	414	745	20	197	79	75	138,0	86,9	202-01-177-0700
800	570	886	5654	314	847	20	340	77	43	172,0	102,0	202-01-300-0800
900	610	990	7110	344	949	20	348	76	44	197,0	116,0	202-01-306-0900
1000	630	1098	8765	394	1051	20	323	68	46	201,0	136,0	202-01-255-1000
1100	610	1198	10540	414	1155	20	235	57	72	326,0	142,0	202-01-204-1100
1200	610	1264	11794	414	1255	20	223	54	82	356,0	154,0	202-01-204-1200
1300	620	1364	13818	394	1355	20	265	57	76	419,0	160,0	202-01-255-1300
1400	640	1464	15980	414	1455	20	264	57	81	472,0	175,0	202-01-255-1400
1500	670	1564	18299	444	1555	20	263	57	87	504,0	191,0	202-01-256-1500
1600	700	1664	20776	474	1655	20	262	58	92	535,0	208,0	202-01-257-1600
1700	580	1764	23409	354	1755	20	261	39	98	1130,0	200,0	202-01-254-1700
1800	600	1864	26199	374	1855	20	260	39	103	1200,0	215,0	202-01-253-1800
1900	620	1963	29132	394	1955	20	254	38	113	1320,0	230,0	202-01-251-1900
2000	660	2061	32204	434	2055	20	242	39	128	1360,0	250,0	202-01-236-2000
2100	600	2161	35466	368	2155	20	306	33	104	1690,0	261,0	202-01-264-2100
2200	620	2260	38865	388	2255	20	299	34	113	1810,0	277,0	202-01-267-2200

\*WF = wirksame Fläche / effective area Weitere Abmessungen und Werkstoffe auf Anfrage. / \*\*I = Mittenabstand / center distance

Other dimensions and materials on request.

### Ausführung 3

### Model 3

Druckstufe 1 barg (PN 1)  
Design pressure 1 barg (PN 1)

Bewegun  
Mov

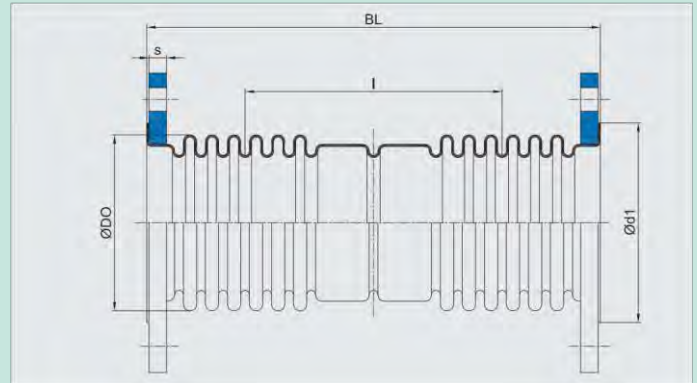

DN	Länge Length	Balg Bellows				Flansch Flanges			gsaufnahme element		Verstellkr Spr		Gewicht Weight	Artikel Article
		BL mm	ØDO	WF* cm <sup>2</sup>	mm	l** mm	Ød1	s mm	mm	axial	lateral	axial		
									2δN mm	2λN mm	Cδ N/mm	Cλ N/mm	kg	
50	235	69	28	132	80	20			38	64	57	5,4	5,9	202-01-038-0050
65	245	87	46	150	98	20			41	63	53	6,6	6,9	202-01-041-0065
80	270	114	79	137	113	20			61	69	32	7,9	8,0	202-01-061-0080
100	240	145	131	116	141	22			72	55	24	14,0	9,9	202-01-072-0100
125	245	170	187	120	170	22			69	46	31	24,0	12,1	202-01-069-0125
150	310	204	271	154	201	24			97	68	26	18,0	16,2	202-01-097-0150
200	285	258	444	144	252	16			90	47	49	61,0	13,2	202-01-090-0200
250	285	312	669	144	306	16			85	36	59	111,0	15,9	202-01-085-0250
300	285	363	923	144	357	16			83	30	68	178,0	20,8	202-01-083-0300
350	295	401	1121	169	391	16			86	34	62	148,0	26,1	202-01-086-0350
400	345	458	1464	195	442	16			116	46	50	115,0	29,8	202-01-116-0400
450	345	509	1830	195	493	16			113	40	55	159,0	34,3	202-01-113-0450
500	355	560	2238	194	544	16			94	31	82	297,0	35,9	202-01-094-0500
550	360	609	2676	192	595	20			90	27	98	429,0	49,6	202-01-090-0550
600	410	672	3211	211	643	20			114	34	102	436,0	57,9	202-01-114-0600
700	465	781	4358	266	745	20			139	45	85	321,0	69,0	202-01-139-0700
800	465	883	5634	266	847	20			137	39	95	463,0	78,7	202-01-137-0800
900	465	985	7072	266	949	20			134	34	105	642,0	87,7	202-01-134-0900
1000	465	1087	8674	266	1051	20			131	30	115	862,0	96,8	202-01-131-1000

1100	465	1191	10476	266	1155	20	129	27	125	1140,0	107,0	202-01-129-1100
1200	480	1263	11784	315	1255	20	148	31	113	844,0	116,0	202-01-148-1200
1300	480	1363	13787	315	1355	20	150	29	122	1070,0	125,0	202-01-150-1300
1400	480	1463	15947	315	1455	20	150	27	130	1320,0	134,0	202-01-150-1400
1500	480	1563	18264	315	1555	20	148	25	139	1620,0	143,0	202-01-148-1500
1600	480	1663	20737	315	1655	20	152	24	148	1950,0	152,0	202-01-152-1600
1700	480	1763	23368	315	1755	20	148	22	157	2330,0	161,0	202-01-148-1700
1800	480	1863	26156	315	1855	20	149	21	166	2750,0	170,0	202-01-149-1800
1900	480	1963	29101	315	1955	20	150	20	174	3230,0	179,0	202-01-150-1900
2000	480	2063	32204	315	2055	20	150	19	183	3750,0	189,0	202-01-150-2000
2100	480	2163	35463	315	2155	20	149	18	192	4320,0	198,0	202-01-149-2100
2200	480	2263	38879	315	2255	20	147	17	201	4960,0	206,0	202-01-147-2200

\*WF = wirksame Fläche / effective area Weitere Abmessungen und Werkstoffe auf Anfrage. / \*\*I = Mittenabstand / center distance

Other dimensions and materials on request.

## Abgaskompensator mit Festflanschen

### Typ 204

### Typ 205 (mit Innenleitrohr) Exhaust expansion with fixed flanges

Der Typ 204 ist ein mehrlagiger Abgaskompensator mit Festflanschen. Er ist speziell konzipiert für den Betrieb in Anlagen mit geringen Betriebsdrücken (bis max. 1 barg).

Dieser Kompensator lässt sowohl axiale, laterale wie auch angulare Bewegungen zu.

#### Beschreibung

Neben den aufgeführten Standardbaulängen kann die Baulänge speziell auf Ihre Bedürfnisse angepasst gefertigt werden. Dieser Kompensator kann auch in anderen Werkstoffen (siehe Seite 179) gefertigt werden.

Die angegebenen Bewegungen stellen die einzelnen Maximalwerte dar. Zur Ermittlung kombinierter Bewegungsmöglichkeiten verwenden Sie bitte das Bewegungsschaubild auf Seite 10.

#### Ausführung

Zur Realisierung größerer Kompensatorenbaulängen sind Varianten mit Zwischenrohr aus Balgmaterial (Ausführung 3) bzw. aus einem eingeschweißten Zwischenrohr (Ausführung 2) erhältlich.

### Type 204

### Type 205 (with internal sleeve)

#### Anwendung

Abgaskompensatoren kommen in einer Vielzahl von Anwendungen zum Einsatz, z. B. Turbinenauslassstutzen, Aggregaten, Generatoren, Schiffsantriebe, Erstausrüster-Motoren und Hilfssysteme.

Abgaskompensatoren können für jede spezielle Anforderung und Anwendung kundenspezifisch angefertigt werden.

#### Vorteile

- Gasdicht und beständig gegen Korrosion und hohen Temperaturen
- Nimmt Schwingungen auf
- Die leichte Bauweise in Kombination mit sehr niedrigen Federraten verringern die auf die Rohrleitungskomponenten wirksamen Lasten
- Platzsparend



Type 204 is a multi-layer exhaust expansion joint with fixed flanges. It is designed specifically for operation in installations with low operating pressures (up to maximum 1 barg).

This expansion joint allows axial, lateral and angular movements.

#### Description

In addition to the given standard lengths, other lengths are available to meet specific requirements. This expansion joint can also be produced in other materials (see page 179).

The specified movements represent the individual maximum values. For determining combined movements, refer to the movement diagram on page 10.

#### Versions

For longer expansion joint lengths, inversions are available with an intermediate pipe of bellows material (version 3) or a welded intermediate pipe (version 2).

#### Applications

Exhaust expansion joints are used in a wide range of applications, e.g. turbine exhausts, apparatus, generators, marine propulsion, OEM motors and auxiliary systems.

Exhaust expansion joints can be made to suit all specific customer requirements and applications.

#### Advantages

- Gas-tight and resistant to corrosion and high temperatures
- Absorb vibrations
- Lightweight design combined with very low spring rates reduce loads exerted on pipeline components
- Space-saving

## Abgaskompensator mit Festflanschen

### Typ 204

### Typ 205 (mit Innenleitrohr) Exhaust expansion with fixed flanges

### Type 204

### Type 205 (with internal sleeve)

**Einsatzbeispiele** Flüssige und gasförmige Medien im Niederdruckbetrieb, z. B. Abgasanlagen im Schiffbau, Biogasanlagen, Blockheizkraftwerke etc.

**Standardmäßiger Aufbau** Mehrlagiger Wellrohrbalg aus 1.4541 mit glatten Flanschen aus C-Stahl (roh) gebohrt nach DIN 86044-1.

**Zulässige Betriebsdaten (Standard)** 1,0 barg / 550 °C  
Höhere Drücke auf Anfrage.

**Zubehör** Innenleitrohr, Außenschutzrohr

**Hinweis** Bei Verwendung von Leitrohren vermindert sich die Möglichkeit der Aufnahme der lateralen oder angularen Bewegungen um mind. 90 %. Die Ausführung 3 ist nicht vakuumfest. Bitte beachten Sie bei Ihrer Planung die Medienverträglichkeit der zu verwendenden Kompensatormaterialien.

**Application examples** Liquid and gaseous media in low pressure operation, e.g. exhaust systems in shipbuilding, biogas plants, block-type thermal power stations, etc.

**Standard design** Multi-layer corrugated tube bellows of 1.4541 with smooth flanges of carbon steel (raw) drilled according to DIN 86044-1.

**Permissible operating data** 1.0 barg / 550 °C  
Higher pressures on request.

**Accessories** Internal sleeve, external protective sleeve

**Note** When using internal sleeves, the possibility to compensate for lateral or angular movements reduces by minimum 90 %. Version 3 is not vacuum-tight. To be noted is that the media compatibility of the expansion joint material to be used should be taken into account in the planning phase.

## Ausführungsvarianten / Versions

**Ausführung 1 / Model 1**



**Ausführung 2 / Model 2**



**Ausführung 3 / Model 3**



## Ausführung 1

### Model 1

Druckstufe 1 barg (PN 1)

Design pressure 1 barg (PN 1)

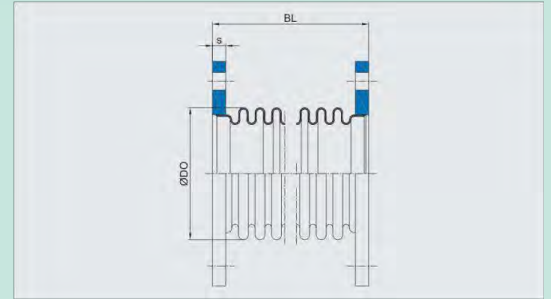

DN	Länge Length	Balg Bellow		Flansch Flanges	Bewegungsaufnahm Movement			Verstellkraftrate Springrate			Gewicht Weight	Artikel Article
		BL mm	ØDO mm		WF* cm <sup>2</sup>	s mm	axial 2δN mm	lateral 2ΔN mm	angular e 2αN °/deg.	Cδ N/mm		
50	140	69	28	20	30	18	50	73	42,0	0,6	5,8	204-01-030-0050
50	210	69	28	20	49	50	50	45	9,2	0,4	5,9	204-01-049-0050
65	130	87	46	20	34	15	50	64	79,0	0,9	6,7	204-01-034-0065
65	190	87	46	20	55	39	50	40	18,0	0,6	6,9	204-01-055-0065
65	235	87	46	20	73	68	50	31	8,3,0	0,4	7,0	204-01-073-0065
80	135	114	79	20	34	8	38	64	272,0	1,4	7,6	204-01-034-0080
80	180	114	79	20	56	22	50	38	59,0	0,9	7,9	204-01-056-0080
80	235	114	79	20	85	51	50	26	18,0	0,6	8,0	204-01-085-0080
100	145	145	131	22	49	9	43	40	359,0	1,5	9,5	204-01-049-0100
100	180	144	130	22	70	19	50	29	107,0	1,1	9,6	204-01-070-0100
100	255	144	129	22	119	59	50	27	33,0	1,0	10,7	204-01-119-0100
125	145	171	188	22	49	7	36	46	602,0	2,4	11,7	204-01-049-0125
125	195	171	187	22	84	23	50	42	184,0	2,2	12,7	204-01-084-0125
125	290	172	186	22	125	65	50	47	50,0	2,4	14,4	204-01-125-0125
150	165	204	271	24	54	7	33	51	789,0	3,8	15,3	204-01-054-0150
150	240	204	271	24	109	31	50	26	95,0	1,9	15,9	204-01-109-0150
150	390	203	266	24	158	94	50	48	35,0	3,5	19,3	204-01-158-0150
200	155	257	442	16	76	10	36	40	713,0	4,9	11,4	204-01-076-0200
200	225	256	440	16	130	32	50	24	132,0	2,9	12,4	204-01-130-0200
200	275	259	444	16	149	48	50	32	98,0	4,0	13,8	204-01-149-0200

## Typ 204 Abmessungen

## Type 204 Specifications

250	155	309	663	16	67	7	26	59	1520,0	11,0	13,6	204-01-067-0250
250	275	314	673	16	144	38	50	39	178,0	7,3	16,6	204-01-144-0250
250	370	313	667	16	194	73	50	47	96,0	8,6	22,1	204-01-194-0250
300	170	365	927	16	77	7	25	70	2440,0	18,0	19,6	204-01-077-0300
300	220	370	943	16	118	18	39	21	295,0	5,3	19,6	204-01-118-0300
300	385	365	923	16	207	70	50	48	124,0	13,0	28,1	204-01-207-0300
350	135	404	1132	16	54	3	16	39	2800,0	13,0	23,1	204-01-054-0350
350	210	402	1126	16	118	16	35	22	383,0	6,9	24,8	204-01-118-0350
350	365	400	1113	16	219	64	50	45	170,0	14,0	34,0	204-01-219-0350
400	185	461	1478	16	90	8	23	59	2280,0	25,0	27,8	204-01-090-0400
400	260	461	1478	16	151	23	39	36	494,0	15,0	29,8	204-01-151-0400
400	365	457	1459	16	226	56	50	44	243,0	18,0	38,0	204-01-226-0400
450	185	511	1842	16	91	7	21	69	3330,0	36,0	32,0	204-01-091-0450
450	260	511	1842	16	152	21	35	42	720,0	22,0	34,3	204-01-152-0450
450	365	510	1832	16	223	49	50	44	303,0	23,0	43,5	204-01-223-0450
500	210	566	2263	16	108	8	23	72	3600,0	46,0	34,7	204-01-108-0500
500	305	564	2254	16	184	27	39	45	698,0	28,0	37,2	204-01-184-0500
500	415	564	2248	16	270	59	50	47	320,0	29,0	47,3	204-01-270-0500
600	250	679	3257	20	101	6	17	129	9320,0	116,0	54,2	204-01-101-0600
600	340	679	3257	20	177	21	31	74	1740,0	67,0	58,0	204-01-177-0600
600	460	679	3257	20	279	52	49	47	455,0	43,0	63,8	204-01-279-0600
700	230	777	4335	20	98	5	15	150	14100,0	180,0	62,3	204-01-098-0700
700	320	778	4341	20	176	18	27	82	2590,0	99,0	66,7	204-01-176-0700
700	460	781	4358	20	283	45	43	47	608,0	56,0	73,4	204-01-283-0700
800	200	886	5654	20	80	3	10	169	38200,0	265,0	71,0	204-01-080-0800
800	290	886	5654	20	156	12	21	85	4810,0	133,0	76,0	204-01-156-0800
800	440	884	5640	20	282	40	38	50	847,0	78,0	83,7	204-01-282-0800

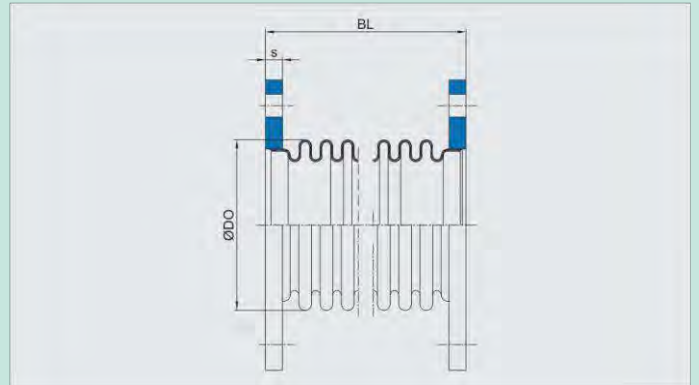

900	220	990	7110	20	79	2	9	173	49100,0	342,0	76,3	204-01-079-0900
900	305	990	7110	20	144	9	17	87	6400,0	171,0	81,9	204-01-144-0900
900	425	990	7110	20	247	28	29	52	1380,0	103,0	93,4	204-01-247-0900

\*WF = wirksame Fläche / effective area

Weitere Abmessungen und Werkstoffe auf Anfrage. /  
Other dimensions and materials on request.

## Ausführung 1

### Model 1

#### Druckstufe 1 barg (PN 1) Design pressure 1 barg (PN 1)

DN	Länge Length	Balg Bellow		Flansch Flanges	Bewegungsaufnahm Movement lateral			Verstellkraftrate Springrate			Gewicht Weight	Artikel Article
		ØDO mm	WF* cm <sup>2</sup>		s mm	axial 2ΔN mm	angular e 2αN %/deg.	angularaxiallateral Cδ N/mm	Cλ N/mm	Cα Nm/deg.		
1000	215	1096	8749	20	71	2	7	165	60400	399,0	84,1	204-01-071-1000
1000	275	1098	8765	20	120	6	13	92	12100	224,0	93,5	204-01-120-1000
1000	425	1093	8724	20	246	25	26	55	1790	133,0	104,0	204-01-246-1000
1100	225	1198	10540	20	95	3	9	144	35600	421,0	96,0	204-01-095-1100
1100	315	1194	10503	20	170	11	16	95	7630	278,0	103,0	204-01-170-1100



## Typ 204 Abmessungen

## Type 204 Specifications

1100	435	1197	10531	20	274	28	27	55	1750	159,0	114,0	204-01-274-1100
1200	195	1264	11794	20	101	3	9	163	44200	533,0	104,0	204-01-101-1200
1200	285	1264	11813	20	178	11	16	101	8860	329,0	112,0	204-01-178-1200
1200	435	1259	11765	20	286	30	26	71	2040	232,0	124,0	204-01-286-1200
1300	165	1366	13818	20	75	1	6	218	122800	835,0	108,0	204-01-075-1300
1300	225	1364	13818	20	127	5	10	151	30600	580,0	112,0	204-01-127-1300
1300	345	1364	13797	20	227	16	19	78	4880	299,0	125,0	204-01-227-1300
1400	165	1466	15980	20	75	1	6	234	152400	1040,0	116,0	204-01-075-1400
1400	225	1464	15980	20	127	4	10	162	38000	719,0	121,0	204-01-127-1400
1400	345	1464	15958	20	227	15	18	84	6050	371,0	134,0	204-01-227-1400
1500	165	1565	18287	20	75	1	5	259	192400	1320,0	124,0	204-01-075-1500
1500	225	1564	18299	20	127	4	9	173	46400	879,0	129,0	204-01-127-1500
1500	345	1564	18275	20	227	14	17	90	7400	453,0	143,0	204-01-227-1500
1600	165	1664	20750	20	75	1	5	285	239600	1650,0	132,0	204-01-075-1600
1600	225	1664	20776	20	127	4	8	184	56000	1070,0	137,0	204-01-127-1600
1600	345	1664	20750	20	227	13	16	95	8930	547,0	152,0	204-01-227-1600
1700	165	1763	23368	20	76	1	5	313	298000	2030,0	140,0	204-01-076-1700
1700	225	1764	23409	20	127	4	8	195	66900	1270,0	145,0	204-01-127-1700
1700	345	1763	23368	20	228	13	15	105	11100	677,0	161,0	204-01-228-1700
1800	165	1864	26142	20	76	1	4	343	363900	2490,0	145,0	204-01-076-1800
1800	225	1864	26199	20	127	3	7	206	79100	1500,0	153,0	204-01-127-1800
1800	345	1864	26142	20	229	12	14	115	13600	830,0	170,0	204-01-229-1800
1900	165	1962	29117	20	74	1	4	390	448500	3150,0	152,0	204-01-074-1900
1900	225	1963	29132	20	126	3	7	225	95100	1820,0	161,0	204-01-126-1900
1900	345	1963	29132	20	228	11	13	125	16400	1020,0	179,0	204-01-228-1900
2000	165	2061	32204	20	72	1	4	425	529400	3800,0	163,0	204-01-072-2000
2000	225	2061	32204	20	121	3	6	255	115000	2280,0	170,0	204-01-121-2000

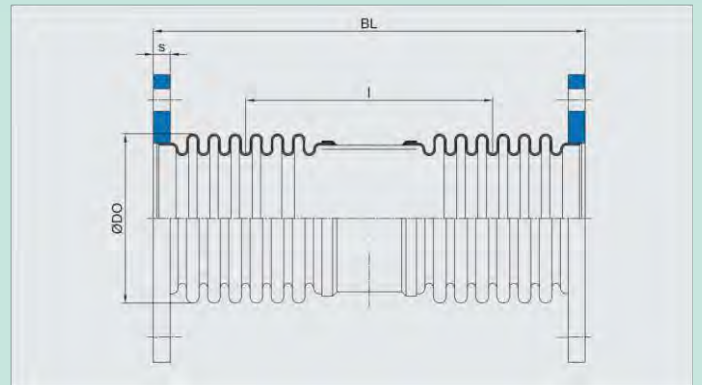

2000	344	2061	32204	20	144	0	0	142	16500	1270,0	189,0	204-01-144-2000
2100	170	2160	35449	20	80	1	4	359	485600	3540,0	172,0	204-01-080-2100
2100	230	2161	35466	20	131	3	7	208	102500	2040,0	184,0	204-01-131-2100
2100	350	2162	35483	20	231	10	12	111	17200	1100,0	208,0	204-01-231-2100
2200	170	2260	38865	20	80	1	4	375	556200	4050,0	180,0	204-01-080-2200
2200	230	2260	38865	20	131	3	6	225	121600	2430,0	192,0	204-01-131-2200
2200	350	2260	38865	20	229	10	11	125	21200	1350,0	217,0	204-01-229-2200

\*WF = wirksame Fläche / effective area

Weitere Abmessungen und Werkstoffe auf Anfrage. /  
Other dimensions and materials on request.

## Ausführung 2

### Model 2

Druckstufe 1 barg (PN 1)

Bewegun  
Mov

aftrate  
ingrate

## Typ 204 Abmessungen

### Type 204 Specifications

Design pressure 1 barg (PN 1)

	Länge Length	Balg Bellow			Flansch Flanges	gsaufnahme ement		Verstellkr Spr		Gewicht Weight	Artikel Article
		BL mm	ØDO cm <sup>2</sup>	WF* mm		I** mm	s mm	axial 2δN mm	lateral 2λN mm		
50	335	69	28	194	20	60	140	37	1,6	6,4	204-01-060-0050
65	315	87	46	184	20	69	120	32	2,6	7,5	204-01-069-0065
80	360	114	79	239	20	68	122	32	3,1	9,3	204-01-064-0080
100	355	145	131	225	22	99	123	20	3,8	11,4	204-01-092-0100
125	385	171	188	255	22	99	122	23	4,9	14,7	204-01-094-0125
150	420	204	271	276	24	109	119	26	6,6	19,4	204-01-101-0150
200	325	257	442	186	16	152	77	20	19,0	15,2	204-01-135-0200
250	385	309	663	246	16	134	79	30	23,0	21,7	204-01-122-0250
300	395	365	927	245	16	167	77	35	41,0	30,4	204-01-153-0300
350	365	404	1132	241	16	173	57	20	28,0	33,3	204-01-126-0350
400	410	461	1478	243	16	212	75	30	53,0	39,7	204-01-187-0400
450	440	511	1842	274	16	201	77	35	61,0	47,4	204-01-184-0450
500	475	566	2263	291	16	223	79	36	72,0	49,4	204-01-199-0500
600	580	679	3257	374	20	202	79	65	117,0	76,2	204-01-180-0600
700	610	777	4335	414	20	197	79	75	138,0	86,9	204-01-177-0700
800	570	886	5654	314	20	340	77	43	172,0	102,0	204-01-300-0800
900	610	990	7110	344	20	348	76	44	197,0	116,0	204-01-306-0900

1000	630	1098	8765	394	20	323	68	46	201,0	136,0	204-01-255-1000
1100	610	1198	10540	414	20	235	57	72	326,0	142,0	204-01-204-1100
1200	610	1264	11794	414	20	223	54	82	356,0	154,0	204-01-204-1200
1300	620	1364	13818	394	20	265	57	76	419,0	160,0	204-01-255-1300
1400	640	1464	15980	414	20	264	57	81	472,0	175,0	204-01-255-1400
1500	670	1564	18299	444	20	263	57	87	504,0	191,0	204-01-256-1500
1600	700	1664	20776	474	20	262	58	92	535,0	208,0	204-01-257-1600
1700	580	1764	23409	354	20	261	39	98	1130,0	200,0	204-01-254-1700
1800	600	1864	26199	374	20	260	39	103	1200,0	215,0	204-01-253-1800
1900	620	1963	29132	394	20	254	38	113	1320,0	230,0	204-01-251-1900
2000	660	2061	32204	434	20	242	39	128	1360,0	250,0	204-01-236-2000
2100	600	2161	35466	368	20	306	33	104	1690,0	261,0	204-01-264-2100
2200	620	2260	38865	388	20	299	34	113	1810,0	277,0	204-01-267-2200

\*WF = wirksame Fläche / effective area Weitere Abmessungen und Werkstoffe auf Anfrage. / \*\*I = Mittenabstand / center distance request.

Other dimensions and materials on

## Ausführung 3

### Model 3

Druckstufe 1 barg (PN 1)  
Design pressure 1 barg (PN 1)

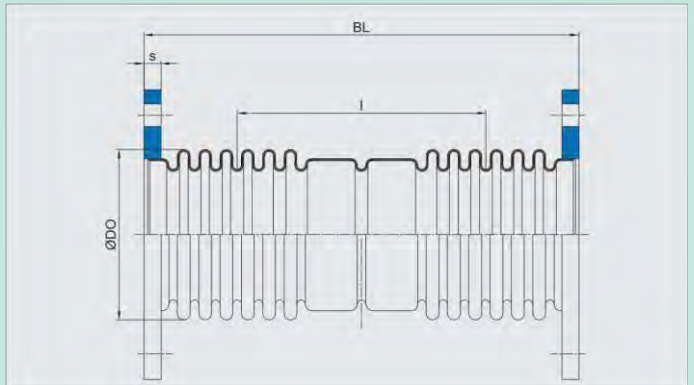

DN	Länge Length	Balg Bellows			Flansch Flanges	gsaufnahme ement	Verstellkr Spr		Gewicht Weight	Artikel Article	
		BL mm	ØDO WF* cm <sup>2</sup>	mm			I** mm	s mm			axial 2λN mm
50	235	69	28	132	20	38	61	57	5,4	5,9	204-01-038-0050
65	245	87	46	150	20	41	62	53	6,6	6,9	204-01-041-0065
80	270	114	79	137	20	61	67	32	7,9	8,0	204-01-061-0080
100	240	145	131	116	22	72	53	24	14,0	9,9	204-01-072-0100
125	245	170	187	120	22	69	45	31	24,0	12,1	204-01-069-0125
150	310	204	271	154	24	97	66	26	18,0	16,2	204-01-097-0150
200	285	258	444	144	16	90	44	49	61,0	13,2	204-01-090-0200
250	285	312	669	144	16	85	34	59	111,0	15,9	204-01-085-0250
300	285	363	923	144	16	83	28	68	178,0	20,8	204-01-083-0300
350	295	401	1121	169	16	86	33	62	148,0	26,1	204-01-086-0350
400	345	458	1464	195	16	116	45	50	115,0	29,8	204-01-116-0400
450	345	509	1830	195	16	113	39	55	159,0	34,3	204-01-113-0450
500	355	560	2238	194	16	94	30	82	297,0	35,9	204-01-094-0500
550	360	609	2676	192	20	90	26	98	429,0	49,6	204-01-090-0550

600	410	672	3211	211	20	114	33	102	436,0	57,9	204-01-114-0600
700	465	781	4358	266	20	139	44	85	321,0	69,0	204-01-139-0700
800	465	883	5634	266	20	137	38	95	463,0	78,7	204-01-137-0800
900	465	985	7072	266	20	134	33	105	642,0	87,7	204-01-134-0900
1000	465	1087	8674	266	20	131	30	115	862,0	96,8	204-01-131-1000
1100	465	1191	10476	266	20	129	26	125	1140,0	107,0	204-01-129-1100
1200	480	1263	11784	315	20	148	31	113	844,0	116,0	204-01-148-1200
1300	480	1363	13787	315	20	150	29	122	1070,0	125,0	204-01-150-1300
1400	480	1463	15947	315	20	150	27	130	1320,0	134,0	204-01-150-1400
1500	480	1563	18264	315	20	148	25	139	1620,0	143,0	204-01-148-1500
1600	480	1663	20737	315	20	152	24	148	1950,0	152,0	204-01-152-1600
1700	480	1763	23368	315	20	148	22	157	2330,0	161,0	204-01-148-1700
1800	480	1863	26156	315	20	149	21	166	2750,0	170,0	204-01-149-1800
1900	480	1963	29101	315	20	150	20	174	3230,0	179,0	204-01-150-1900
2000	480	2063	32204	315	20	150	19	183	3750,0	189,0	204-01-150-2000
2100	480	2163	35463	315	20	149	18	192	4320,0	198,0	204-01-149-2100
2200	480	2263	38879	315	20	147	17	201	4960,0	206,0	204-01-147-2200

\*WF = wirksame Fläche / effective area Weitere Abmessungen und Werkstoffe auf Anfrage. / \*\*I = Mittenabstand / center distance Other dimensions and materials on request.

## mit Anschweißenden, einlagig

### Typ 206

### Typ 207 (mit Innenleitrohr)

Der Typ 206 ist ein einlagiger Axialkompensator mit Anschweißenden.

Er ist konzipiert für den Betrieb in Anlagen mit Betriebsdrücken bis max. 16 barg (siehe zulässige Betriebsdaten).

#### Wichtiger Hinweis

Diese Kompensatoren sind einlagig und daher nicht für Schwingungen geeignet.

#### Important note

These expansion joints are single layer and therefore not suitable for vibrations.

## with weld ends, single layer

### Type 206

### Type 207 (with internal sleeve)



Type 206 is a single layer axial expansion joint with weld ends.

It is designed specifically for operation in installations with operating pressures up to max. 16 barg (see permissible operating data).

## Typ 206 Abmessungen Ausführung 1

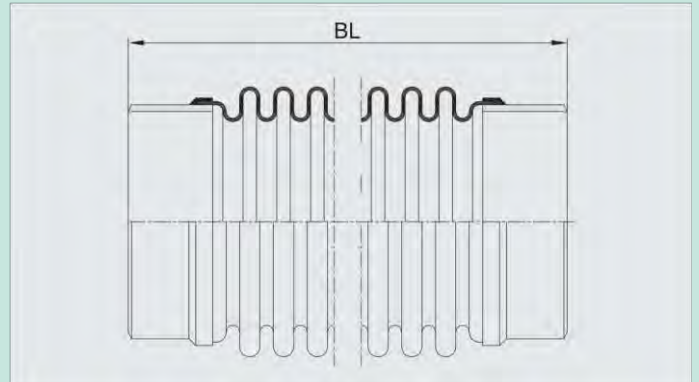

**Einsatzbeispiele** Flüssige, gasförmige Medien z. B. Wasser und Entwässerung. Vakuumfest.

**Standardmäßiger Aufbau** Einlagiger Wellrohrbalg aus 1.4541 mit Anschweißenden aus C-Stahl.

**Zulässige Betriebsdaten** (Standard) DN 15 - DN 50 / 16 barg / 20 °C  
Höhere Drücke und Nennweiten auf Anfrage.

**Zubehör** Innenleitrohr, Außenschutzrohr

**Hinweis** Bei Verwendung von Leitrohren vermindert sich die Möglichkeit der Aufnahme der lateralen oder angularen Bewegungen um mind. 90 %. Der Typ 206 ist vakuumfest. Bitte beachten Sie bei Ihrer Planung die Medienverträglichkeit der zu verwendenden Kompensatorenmaterialien.

**Application examples** Liquid and gaseous media e. g. water and drainage. Vacuum-tight.

**Standard design** Single layer corrugated tube bellows of 1.4541 with weld ends of carbon steel.

**Permissible operating data** DN 15 - DN 50 / 16 barg / 20 °C  
Higher pressures on request.

**Accessories** Internal sleeve, external protective sleeve

**Note** When using internal sleeves, the possibility to compensate for lateral or angular movements reduces by minimum 90 %. Type 206 is vacuum-tight. To be noted is that the media compatibility of the expansion joint material to be used should be taken into account in the planning phase.

## Type 206 Specifications Model 1

**Druckstufe 16 barg (PN 16)**  
**Design pressure 16 barg (PN 16)**

DN	Länge Length	Bewegungsaufnahme Movement		Gewicht Weight		Artikel Article
		axial 25N mm	lateral 2AN mm	kg		
15	175	12,0	5	0,1		206-16-12-015
20	175	12,0	5	0,2		206-16-12-020
25	185	15,0	8	0,3		206-16-15-025
32	185	15,0	12	0,4		206-16-15-032
40	190	15,0	12	0,5		206-16-15-040
50	205	22,0	11	0,7		206-16-22-050

Weitere Abmessungen und Werkstoffe auf Anfrage.  
/ Other dimensions and materials on request.



drehbare Losflansche, einlagig

Typ 208

Typ 209 (mit Innenleitrohr) with loose flanges, single layer



## Type 208

Der Typ 208 ist ein einwandiger Axialkompensator mit drehbaren Losflanschen.

<b>Einsatzbeispiele</b>	Flüssige, gasförmige oder Medien mit hohem Feststoffanteil (mit Innenleitrohr), z. B. Dampfanlagen, Wasser, Entwässerung, chemische Industrie, Petrochemie etc.
<b>Aufbau</b>	Einlagiger Wellrohrbalg aus 1.4541 mit glatten Flanschen aus C-Stahl (roh). Der Bördel besteht aus umgeformtem Balgmaterial.
<b>Zulässige Betriebsdaten</b>	DN 15 - 150 / 16 barg / 20 °C DN 200 - 250 / 10 barg / 30 °C
<b>Zubehör</b>	Innenleitrohr, Außenschutzrohr
<b>Hinweis</b>	Bei Verwendung von Leitrohren vermindert sich die Möglichkeit der Aufnahme der lateralen oder angularen Bewegungen um mind. 90 %. Der Typ 208 ist vakuumfest. Bitte beachten Sie bei Ihrer Planung die Medienverträglichkeit der zu verwendenden Kompensatorenmaterialien.

### Anforderungen

- Starke Festpunkte und gute Loslager erforderlich
- Große Bewegungen erfordern den Einsatz mehrerer Axialkompensatoren
- Für lange Rohrleitungsabschnitte werden viele Festpunkte und Loslager benötigt
- Höhere Kosten für Festpunkte und Loslager

### Vorteile

- Einfache Lösung für die Kompensation von Temperaturschwankungen
- Keine Strömungsumlenkung
- Kompakte und platzsparende Lösung
- Relativ geringe Kosten

## Type 209 (with internal sleeve)

joints ▫ For long sections of pipeline, numerous fixed points and floating bearings are required

<b>Application examples</b>	Liquid, gaseous or media with a high solids content (with internal sleeve), e.g. steam plants, water, drainage, chemical industry, petrochemistry, etc.
<b>Standard design</b>	Single layer corrugated tube bellows of 1.4541 with smooth flanges of carbon steel (raw). The collar is made from formed bellows material.
<b>Permissible operating data</b>	DN 15 - 150 / 16 barg / 20 °C DN 200 - 250 / 10 barg / 30 °C
<b>Accessories</b>	Internal sleeve, external protective sleeve
<b>Note</b>	When using internal sleeves, the possibility to compensate for lateral or angular movements reduces by minimum 90 %. Type 208 is vacuum-tight. To be noted is that the media compatibility of the expansion joint material to be used should be taken into account in the planning phase.

- Higher costs for fixed points and floating bearings

### Advantages

- Simple solution for temperature fluctuation compensation
- No flow deflection
- Compact and space-saving solution
- Relatively low costs

Type 208 is a single layer axial expansion joint with loose flanges.

### Requirements

Strong fixed points and good floating bearings necessary  
Large movements require the use of several axial expansion

**Typ 208 Abmessungen  
Ausführung 1**

**Type 208 Specifications  
Model 1**

**Druckstufe 10 barg (PN 10)  
Design pressure 10 barg (PN 10)**

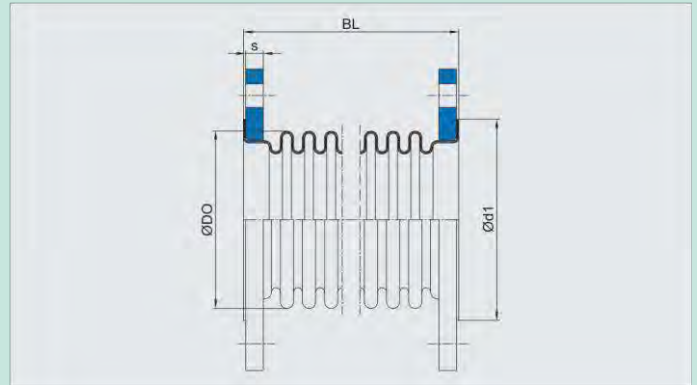

DN	Länge Length		Balg Bellows		Flansch Flanges		Bewegungsaufnahme Movement			Verstellkraftrate Springrate			Gewicht Weight	Artikel Article
	BL mm	WF* cm <sup>2</sup>	mm	mm	axial	lateral	angular	angularaxiallateral						
								25N mm	2ΔN mm	2αN %/deg.	Cδ N/mm	Cλ N/mm		
200	235	250	430	260	24	35	10	17	150	439	18,0	20,5	2008322010	
250	240	305	656	315	26	35	9	14	170	751	31,0	26,2	2008322510	

\*WF = wirksame Fläche / effective area

**Druckstufe 16 barg (PN 16)  
Design pressure 16 barg (PN 16)**

DN	Länge Length		Balg Bellows		Flansch Flanges		Bewegungsaufnahme Movement			Verstellkraftrate Springrate			Gewicht Weight	Artikel Article
	BL mm	WF* cm <sup>2</sup>	mm	mm	axial	lateral	angular	angularaxiallateral						
								25N mm	2ΔN mm	2αN %/deg.	Cδ N/mm	Cλ N/mm		
15	100	36	7,0	48	14	20	11	30	26	9	0,1	1,35	2008411510	
20	100	36	7,0	58	14	20	11	30	26	9	0,1	1,61	2008412010	
25	105	42	10,0	68	14	25	13	30	64	24	0,2	2,40	2008412510	
32	120	50	14,5	78	18	25	13	28	54	23	0,3	3,50	2008413210	
40	125	56	18,0	88	18	25	12	23	172	81	0,9	4,40	2008414010	

**Wichtiger Hinweis**

Die Kompensatoren sind einlagig und daher nicht für Schwingungen geeignet.

**Important note**

The expansion joints are single layer and therefore not suitable for vibrations.

50	150	69	28,0	102	20	30	14	22	142	72	1,2	5,90	2008415010
65	155	89	48,0	108	20	40	17	25	147	120	2,0	6,70	2008416510
80	165	113	79,0	118	20	45	17	23	152	184	3,4	7,80	2008418010
100	170	139	126,0	142	22	45	14	21	169	319	5,6	9,60	2008421010
125	185	166	183,0	170	22	45	13	17	167	359	5,6	11,90	2008421210
150	205	199	264,0	210	24	65	16	15	242	638	18,0	15,80	2008421510

\*WF = wirksame Fläche / effective area

Weitere Abmessungen und Werkstoffe auf Anfrage. /  
Other dimensions and materials on request.



**mit Anschweißenden**

**Typ 210**

**Typ 211 (mit Innenleitrohr)**

Der Typ 210 ist ein mehrlagiger Axialkompensator mit Anschweißenden. Er ist speziell konzipiert für den Betrieb in Anlagen mit Betriebsdrücken bis 63 barg.

**with weld ends**

**Type 210**

**Type 211 (with internal sleeve)**

Dieser Kompensator lässt sowohl axiale, laterale wie auch angulare Bewegungen zu.

### **Beschreibung**

Neben den aufgeführten Standardbaulängen kann die Baulänge speziell auf Ihre Bedürfnisse angepasst gefertigt werden. Dieser Kompensator kann auch in anderen Werkstoffen (siehe Seite 179) gefertigt werden.

Die angegebenen Bewegungen stellen die einzelnen Maximalwerte dar. Zur Ermittlung kombinierter Bewegungsmöglichkeiten verwenden Sie bitte das Bewegungsschaubild auf Seite 10.

Type 210 is a multi-layer axial expansion joint with weld ends. It is designed specifically for operation in installations with operating pressures up to 63 barg.

This expansion joint allows axial, lateral and angular movements.

### **Description**

In addition to the given standard lengths, other lengths are available to meet specific requirements. This expansion joint can also be produced in other materials (see page 179).

The specified movements represent the individual maximum values. For determining combined movements, refer to the movement diagram on page 10.

## Axialkompensator mit Anschweißenden

### Typ 210

### Typ 211 (mit Innenleitrohr) Axial expansion joint with weld ends

### Type 210

## Type 211 (with internal sleeve)

**Einsatzbeispiele** Flüssige, gasförmige oder Medien mit hohem Feststoffanteil (mit Innenleitrohr), z. B. Dampfanlagen, Wasser, Entwässerung, chemische Industrie, Petrochemie etc.

**Standardmäßiger Aufbau** Mehrlagiger Wellrohrbalg aus 1.4541 mit Anschweißenden aus C-Stahl. Ab einer Anschweißendendicke von 3,5 mm ist dieses montagefertig gefast.

**Zulässige Betriebsdaten** (Standard) 16 barg / 120 °C gem. EJMA  
Höhere Drücke auf Anfrage.

**Zubehör** Innenleitrohr, Außenschutzrohr

**Hinweis** Bei Verwendung von Leitrohren vermindert sich die Möglichkeit der Aufnahme der lateralen oder angularen Bewegungen um mind. 90 %. Bitte beachten Sie bei Ihrer Planung die Medienverträglichkeit der zu verwendenden Kompensatorenmaterialien.

**Application examples** Liquid, gaseous or media with a high solids content (with internal sleeve), e.g. steam plants, water, drainage, chemical industry, petrochemistry, etc.

**Standard design** Multi-layer corrugated tube bellows of 1.4541 with weld ends of carbon steel. From a weld end thickness of 3.5 mm, these parts are bevelled ready for installation.

**Permissible operating data** 16 barg / 120 °C acc. to EJMA.  
Higher pressures on request.

**Accessories** Internal sleeve, external protective sleeve

**Note** When using internal sleeves, the possibility to compensate for lateral or angular movements reduces by minimum 90 %. To be noted is that the media compatibility of the expansion joint material to be used should be taken into account in the planning phase.

Model 1

Druckstufe 2,5 barg (PN 2,5)  
Design pressure 2.5 barg (PN 2.5)

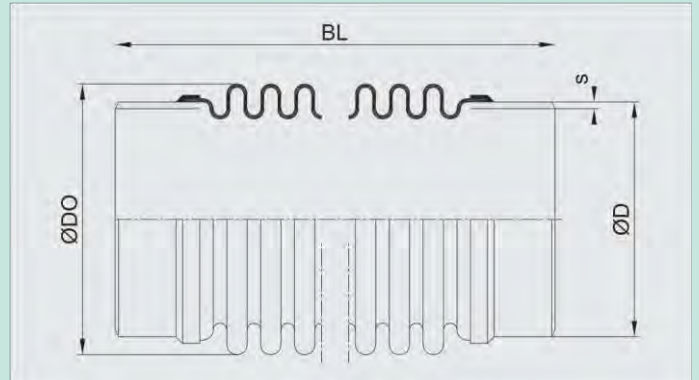

DN	Länge Length	Balg Bellows			Anschweißenden Weld ends			Bewegungsaufnahm Movement			erstelkraftra Springra gularaxiallate			Gewicht Weight	Artikel Article
		BL mm	ØDO	WF* cm²	mm	ØD	s mm	mm	axial 2δN mm	lateral 2λN mm	angular e 2αN %/deg.	Cδ <sup>V</sup> N/mm	Cλ N/mm		
50	215	69	28	60,3	2,9	23	14	44	94	51	0,8	0,7	210-2,5-023-0050		
50	280	69	28	60,3	2,9	38	39	50	58	12	0,5	0,8	210-2,5-038-0050		
65	205	87	46	76,1	2,9	27	12	40	83	95	1,1	0,8	210-2,5-027-0065		
65	270	87	46	76,1	2,9	43	32	50	82	33	1,1	1,3	210-2,5-043-0065		
80	165	114	79	88,9	3,2	26	6	29	83	369	1,9	1,2	210-2,5-026-0080		
80	210	114	79	88,9	3,2	43	17	49	50	77	1,1	1,4	210-2,5-043-0080		
80	270	114	79	88,9	3,2	65	39	50	33	22	0,8	1,5	210-2,5-065-0080		
100	165	145	131	114,3	3,6	37	7	32	51	431	1,9	1,7	210-2,5-037-0100		
100	200	144	130	114,3	3,6	53	15	47	38	129	1,4	1,7	210-2,5-053-0100		
100	275	144	129	114,3	3,6	92	46	50	35	38	1,3	2,6	210-2,5-092-0100		
125	165	171	188	139,7	4,0	38	6	28	60	730	3,1	2,2	210-2,5-038-0125		
125	215	171	187	139,7	4,0	65	18	48	54	200	2,8	3,2	210-2,5-065-0125		
125	315	172	186	139,7	4,0	97	50	50	61	60	3,1	4,9	210-2,5-097-0125		
150	175	204	271	168,3	4,5	41	5	25	66	820	5,0	2,6	210-2,5-041-0150		
150	250	204	271	168,3	4,5	83	24	50	33	103	2,5	3,4	210-2,5-083-0150		
150	405	203	266	168,3	4,5	123	73	50	62	42	4,6	6,8	210-2,5-123-0150		
200	190	257	442	219,1	6,3	57	7	27	52	782	6,3	4,5	210-2,5-057-0200		
200	275	259	441	219,1	6,3	92	24	44	80	296	9,8	7,3	210-2,5-092-0200		
200	310	259	444	219,1	6,3	114	37	50	42	110	5,2	7,1	210-2,5-114-0200		
250	190	309	663	273,0	6,3	50	5	19	77	1640	15,0	6,1	210-2,5-050-0250		
250	310	314	673	273,0	6,3	109	28	42	51	199	9,5	8,8	210-2,5-109-0250		
250	400	313	667	273,0	6,3	149	56	50	60	112	12,0	14,3	210-2,5-149-0250		
300	190	365	927	323,9	7,1	63	6	21	91	3120	24,0	9,1	210-2,5-063-0300		
300	245	370	943	323,9	7,1	119	18	39	27	373	6,9	8,5	210-2,5-119-0300		
300	415	365	923	323,9	7,1	159	53	50	62	147	16,0	17,6	210-2,5-159-0300		
350	190	404	1132	355,6	6,3	54	3	16	50	3630	16,0	8,5	210-2,5-054-0350		
350	265	402	1126	355,6	6,3	117	16	35	29	478	8,9	9,8	210-2,5-117-0350		
350	415	400	1113	355,6	6,3	167	48	50	58	197	18,0	19,7	210-2,5-167-0350		
400	230	461	1478	406,4	6,3	78	7	20	77	2710	32,0	12,5	210-2,5-078-0400		
400	305	461	1478	406,4	6,3	130	20	34	46	586	19,0	14,5	210-2,5-130-0400		
400	410	457	1459	406,4	6,3	183	45	48	58	277	24,0	22,7	210-2,5-183-0400		
450	230	511	1842	457,0	6,3	74	6	17	90	3940	46,0	14,0	210-2,5-074-0450		
450	305	511	1842	457,0	6,3	124	17	29	54	829	28,0	16,3	210-2,5-124-0450		
450	410	510	1832	457,0	6,3	191	42	45	57	351	29,0	22,1	210-2,5-191-0450		
500	240	566	2263	508,0	6,3	82	6	17	94	4340	59,0	15,7	210-2,5-082-0500		
500	340	564	2254	508,0	6,3	140	20	29	58	755	36,0	18,2	210-2,5-140-0500		
500	445	564	2248	508,0	6,3	211	46	45	61	364	38,0	28,3	210-2,5-211-0500		
600	240	679	3257	610,0	6,0	75	5	13	167	10500	151,0	17,3	210-2,5-075-0600		
600	330	679	3257	610,0	6,0	132	15	23	96	1960	87,0	23,9	210-2,5-132-0600		

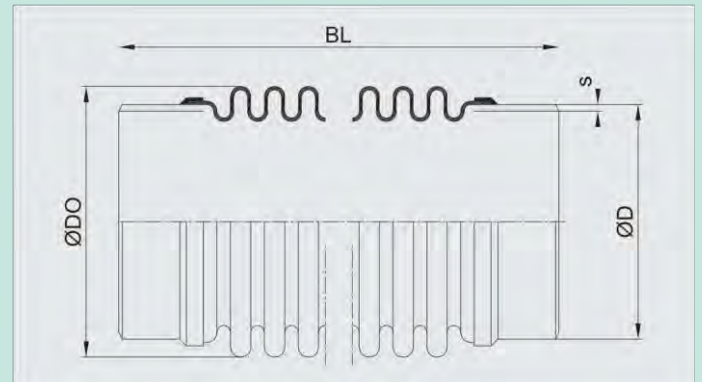

600	450	679	3257	610,0	6,0	207	38	36	61	503	55,0	25,9	210-2,5-207-0600
700	260	777	4335	711,0	6,0	73	4	11	195	16300	234,0	25,5	210-2,5-073-0700
700	350	778	4341	711,0	6,0	131	13	20	107	2910	129,0	29,9	210-2,5-131-0700
700	470	781	4358	711,0	6,0	220	35	33	60	686	73,0	36,6	210-2,5-220-0700
800	230	886	5654	813,0	6,0	62	2	8	219	44300	344,0	29,2	210-2,5-062-0800
800	320	886	5654	813,0	6,0	124	9	16	110	5540	172,0	29,2	210-2,5-124-0800
800	470	884	5640	813,0	6,0	219	31	29	65	955	101,0	41,9	210-2,5-219-0800
900	230	990	7110	914,0	6,0	63	2	7	225	58100	444,0	27,2	210-2,5-063-0900
900	320	990	7110	914,0	6,0	126	8	15	113	7270	222,0	38,5	210-2,5-126-0900
900	440	990	7110	914,0	6,0	211	24	25	68	1580	133,0	41,5	210-2,5-211-0900

\*WF = wirksame Fläche / effective area

Weitere Abmessungen und Werkstoffe auf Anfrage. /  
Other dimensions and materials on request.

## Model 1

### Druckstufe 2,5 barg (PN 2,5)

### Design pressure 2.5 barg (PN 2,5)

DN	Länge Length	Balg Bellow			Anschweißenden Weld ends			Bewegungsaufnahm Movement			Rückstellkraft Springrate			Gewicht Weight	Artikel Article		
								axial	lateral	angular	axial	lateral	angular				
																2δN mm	2ΔN mm
1000	230	1096	WF*	mm	8749	1016,0	s	mm	6,0	66	2	7	214	70700	519,0	36,5	210-2,5-066-1000

e

Ve



1000	290	1098	8765	1016,0	6,0	115	5	12	120	14400	291,0	42,8	210-2,5-115-1000
1000	440	1093	8724	1016,0	6,0	211	22	22	72	2050	173,0	46,1	210-2,5-211-1000
1100	280	1198	10540	1120,0	6,0	84	3	8	187	40600	547,0	43,6	210-2,5-084-1100
1100	370	1194	10503	1120,0	6,0	137	11	13	124	8300	360,0	50,5	210-2,5-137-1100
1100	485	1197	10531	1120,0	6,0	228	28	22	71	2060	206,0	61,2	210-2,5-228-1100
1200	315	1264	11794	1220,0	6,0	80	3	7	212	47400	693,0	47,5	210-2,5-080-1200
1200	400	1264	11813	1220,0	6,0	136	10	12	131	10300	427,0	55,0	210-2,5-136-1200
1200	555	1259	11765	1220,0	6,0	211	30	19	92	2240	301,0	66,6	210-2,5-211-1200
1300	285	1366	13818	1320,0	6,0	62	1	5	283	134600	1090,0	47,4	210-2,5-062-1300
1300	345	1364	13818	1320,0	6,0	96	5	8	197	32900	753,0	51,4	210-2,5-096-1300
1300	460	1364	13797	1320,0	6,0	180	16	15	102	5650	388,0	63,9	210-2,5-180-1300
1400	285	1466	15980	1420,0	6,0	62	1	4	304	167000	1350,0	51,0	210-2,5-062-1400
1400	345	1464	15980	1420,0	6,0	96	5	7	211	40900	934,0	55,4	210-2,5-096-1400
1400	460	1464	15958	1420,0	6,0	179	15	14	109	6990	481,0	68,8	210-2,5-179-1400
1500	285	1565	18287	1520,0	6,0	60	1	4	336	207600	1710,0	54,5	210-2,5-060-1500
1500	345	1564	18299	1520,0	6,0	95	4	7	225	49700	1150,0	59,2	210-2,5-095-1500
1500	460	1564	18275	1520,0	6,0	178	14	13	116	8520	589,0	73,5	210-2,5-178-1500
1600	285	1664	20750	1620,0	6,0	59	1	4	370	256800	2140,0	58,2	210-2,5-059-1600
1600	345	1664	20776	1620,0	6,0	95	4	6	239	60000	1380,0	63,1	210-2,5-095-1600
1600	460	1664	20750	1620,0	6,0	178	13	12	124	10300	711,0	78,4	210-2,5-178-1600
1700	285	1763	23368	1720,0	6,0	58	1	3	407	314200	2640,0	61,8	210-2,5-058-1700
1700	345	1764	23409	1720,0	6,0	94	4	6	254	71300	1650,0	67,1	210-2,5-094-1700
1700	460	1763	23368	1720,0	6,0	174	12	11	136	12600	879,0	83,3	210-2,5-174-1700
1800	285	1864	26142	1820,0	6,0	56	1	3	445	378200	3240,0	62,5	210-2,5-056-1800
1800	345	1864	26199	1820,0	6,0	94	3	5	268	84200	1950,0	70,9	210-2,5-094-1800
1800	460	1864	26142	1820,0	6,0	170	12	10	149	15200	1080,0	88,1	210-2,5-170-1800
1900	285	1962	29117	1920,0	6,0	54	1	3	506	468500	4090,0	65,9	210-2,5-054-1900
1900	345	1963	29132	1920,0	6,0	92	3	5	293	101100	2370,0	74,9	210-2,5-092-1900
1900	465	1963	29132	1920,0	6,0	166	11	9	163	17600	1320,0	93,0	210-2,5-166-1900
2000	285	2061	32204	2020,0	6,0	53	1	3	552	559700	4940,0	72,6	210-2,5-053-2000
2000	345	2061	32204	2020,0	6,0	88	3	4	331	123500	2970,0	78,8	210-2,5-088-2000
2000	465	2061	32204	2020,0	6,0	159	10	9	184	21700	1650,0	97,9	210-2,5-159-2000
2100	285	2160	35449	2120,0	6,0	65	1	3	467	579200	4590,0	77,3	210-2,5-065-2100
2100	345	2161	35466	2120,0	6,0	111	3	5	269	125500	2650,0	89,2	210-2,5-111-2100



2100	465	2162	35483	2120,0	6,0	205	10	11	144	21200	1420,0	114,0	<b>210-2,5-205-2100</b>
2200	285	2260	38865	2220,0	6,0	65	1	3	487	663400	5260,0	81,0	<b>210-2,5-065-2200</b>
2200	345	2260	38865	2220,0	6,0	109	3	5	293	147200	3160,0	93,4	<b>210-2,5-109-2200</b>
2200	470	2260	38865	2220,0	6,0	197	10	10	163	24500	1760,0	119,0	<b>210-2,5-197-2200</b>

\*WF = wirksame Fläche / effective area

Weitere Abmessungen und Werkstoffe auf Anfrage. /  
Other dimensions and materials on request.

**Typ 210 Abmessungen  
Ausführung 1**

**Type 210 Specifications**

**Model 1**

**Druckstufe 6 barg  
Design pressure 6**

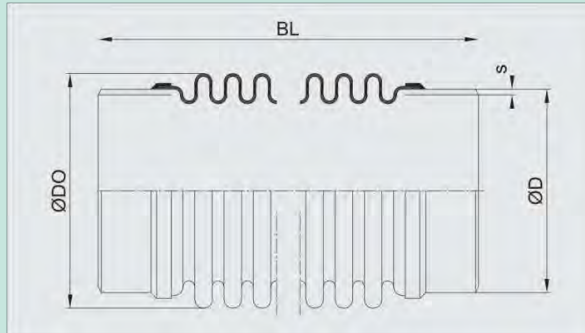

**(PN 6)  
barg (PN 6)**

DN	Länge Length	Balg Bellows			Anschweißenden Weld ends			Bewegungsaufnahme Movement lateral			Rückstellkraftrate Springrate			Gewicht Weight	Artikel Article
		BL mm	ØDO cm <sup>2</sup>	WF* mm	ØD mm	s mm	axial 2ΔN mm	angular e 2αN °/deg.	axial Cδ N/mm	lateral Cλ N/mm	angular Cα Nn/deg.	kg			
50	215	69	28	60,3	2,9	23	14	44	94	51	0,8	0,7	210-06-023-0050		
50	315	69	28	60,3	2,9	40	48	50	84	12	0,7	1,1	210-06-040-0050		
65	205	87	46	76,1	2,9	26	11	38	83	94	1,1	0,8	210-06-026-0065		
65	270	87	46	76,1	2,9	43	32	50	82	33	1,1	1,3	210-06-043-0065		
80	165	114	79	88,9	3,2	25	6	28	83	366	1,9	1,2	210-06-025-0080		
80	210	114	79	88,9	3,2	42	17	47	50	76	1,1	1,4	210-06-042-0080		
80	275	114	77	88,9	3,2	59	37	50	78	45	1,7	2,3	210-06-059-0080		
100	165	145	131	114,3	3,6	35	6	31	51	422	1,9	1,7	210-06-035-0100		
100	205	144	129	114,3	3,6	53	15	47	58	172	2,1	2,0	210-06-053-0100		
100	295	145	127	114,3	3,6	76	42	50	92	73	3,3	4,3	210-06-076-0100		
125	165	171	188	139,7	4,0	35	5	25	60	706	3,1	2,2	210-06-035-0125		
125	215	171	187	139,7	4,0	62	17	46	54	196	2,8	3,2	210-06-062-0125		
125	320	170	182	139,7	4,0	82	43	50	104	92	5,3	6,1	210-06-082-0125		
150	175	204	271	168,3	4,5	38	5	23	66	798	5,0	2,6	210-06-038-0150		
150	260	204	267	168,3	4,5	65	20	40	107	267	8,0	4,9	210-06-065-0150		
150	365	204	262	168,3	4,5	103	53	50	126	112	9,2	9,0	210-06-103-0150		
200	190	257	442	219,1	6,3	51	6	24	52	746	6,3	4,5	210-06-051-0200		
200	275	259	441	219,1	6,3	88	23	42	80	291	9,8	7,3	210-06-088-0200		
200	325	259	435	219,1	6,3	110	38	50	116	253	14,0	11,3	210-06-110-0200		
250	190	309	663	273,0	6,3	46	5	18	77	1590	15,0	6,1	210-06-046-0250		
250	275	314	670	273,0	6,3	86	18	33	97	529	18,0	9,1	210-06-086-0250		
250	365	310	656	273,0	6,3	111	37	44	119	266	22,0	14,9	210-06-111-0250		
300	190	365	927	323,9	7,1	58	5	19	91	2990	24,0	9,1	210-06-058-0300		
300	235	364	924	323,9	7,1	84	12	28	66	925	17,0	10,0	210-06-084-0300		

## Typ 210 Abmessungen Ausführung 1

### Type 210 Specifications

300	295	370	933	323,9	7,1	115	24	38	98	654	26,0	15,0	210-06-115-0300
350	210	396	1104	355,6	6,3	55	4	16	106	4010	33,0	9,5	210-06-055-0350
350	255	398	1110	355,6	6,3	89	11	27	62	1070	19,0	12,4	210-06-089-0350
350	350	400	1108	355,6	6,3	123	27	37	104	561	32,0	20,6	210-06-123-0350
400	250	453	1451	406,4	6,3	65	7	17	104	2310	42,0	12,5	210-06-065-0400
400	315	458	1462	406,4	6,3	117	19	31	82	841	33,0	18,0	210-06-117-0400
400	455	455	1441	406,4	6,3	147	42	39	151	472	61,0	32,7	210-06-147-0400
450	235	510	1836	457,0	6,3	54	4	12	179	6180	91,0	15,5	210-06-054-0450
450	290	514	1851	457,0	6,3	90	11	21	97	1630	50,0	18,3	210-06-090-0450
450	410	513	1830	457,0	6,3	157	34	37	130	737	66,0	31,1	210-06-157-0450
500	245	568	2273	508,0	6,3	61	5	13	174	6280	110,0	17,3	210-06-061-0500
500	340	567	2269	508,0	6,3	108	16	23	102	1200	64,0	20,4	210-06-108-0500
500	440	569	2259	508,0	6,3	171	36	36	139	797	87,0	41,0	210-06-171-0500
600	275	666	3191	610,0	6,0	63	5	11	242	7780	214,0	20,1	210-06-063-0600
600	340	681	3256	610,0	6,0	131	16	23	133	2420	120,0	30,4	210-06-131-0600
600	440	679	3235	610,0	6,0	189	34	33	136	1170	123,0	48,5	210-06-189-0600
700	295	762	4248	711,0	6,0	57	4	8	312	13000	368,0	22,2	210-06-057-0700
700	360	776	4316	711,0	6,0	121	12	18	175	4120	209,0	37,5	210-06-121-0700
700	495	775	4298	711,0	6,0	195	33	30	156	1400	186,0	58,6	210-06-195-0700

\*WF = wirksame Fläche / effective area

Weitere Abmessungen und Werkstoffe auf Anfrage. /  
Other dimensions and materials on request.

# Typ 210 Abmessungen Ausführung 1

## Type 210 Specifications

### Model 1

Druckstufe 6 barg  
Design pressure 6

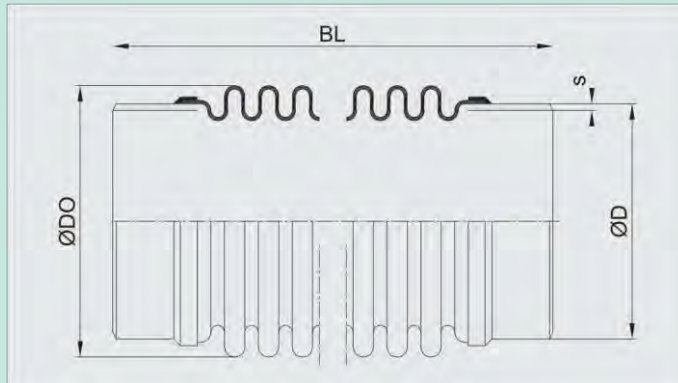

(PN 6)  
barg (PN 6)

Ve

DN	Länge Length	Balg Bellow		Anschweißenden Weld ends		Bewegungsaufnahm Movement			Verrstellkraftrate Springrate			Gewicht Weight	Artikel Article
		BL mm	ØDO WF* cm <sup>2</sup>	mm	ØD mm	s mm	lateral	angular	axial	lateral	angular		
						2δ mm	2λN mm	2αN °/deg.	Cδ N/mm	Cλ N/mm	Cα Nn/deg.	kg	
800	265	878	5586	813,0	8,0	68	3	9	339	31500	526,0	40,9	210-06-068-0800
800	360	878	5586	813,0	8,0	119	11	16	194	5880	301,0	48,4	210-06-119-0800
800	460	885	5618	813,0	8,0	208	28	28	137	2110	214,0	72,5	210-06-208-0800
900	265	979	7011	914,0	8,0	65	3	7	389	44500	758,0	39,0	210-06-065-0900
900	360	980	7019	914,0	8,0	116	9	14	214	8050	416,0	54,5	210-06-116-0900
900	460	986	7047	914,0	8,0	199	24	24	157	2990	307,0	81,7	210-06-199-0900
1000	265	1080	8599	1016,0	8,0	62	2	6	443	61000	1060,0	43,4	210-06-062-1000
1000	360	1080	8599	1016,0	8,0	109	8	11	253	11400	605,0	60,6	210-06-109-1000
1000	460	1092	8679	1016,0	8,0	211	23	23	148	3570	355,0	78,2	210-06-211-1000
1100	320	1184	10424	1120	8,0	68	3	6	481	47000	1390,0	55,9	210-06-068-1100
1100	415	1184	10424	1120	8,0	110	8	10	301	11700	869,0	66,2	210-06-110-1100
1100	480	1200	10569	1120	8,0	200	20	19	173	4940	508,0	90,9	210-06-200-1100
1200	350	1248	11652	1220	8,0	66	3	6	528	61100	1710,0	66,5	210-06-066-1200
1200	445	1251	11681	1220	8,0	114	8	10	288	13300	934,0	77,7	210-06-114-1200
1200	545	1263	11781	1220	8,0	214	22	20	172	4540	560,0	114,0	210-06-214-1200

\*WF = wirksame Fläche / effective area

Weitere Abmessungen und Werkstoffe auf Anfrage. /  
Other dimensions and materials on request.

**Typ 210 Abmessungen**  
**Ausführung 1**

**Type 210 Specifications**



**Typ 210 Abmessungen**  
**Ausführung 1**

**Type 210 Specifications**

**Model 1**

**Druckstufe 10**  
**Design pressure**

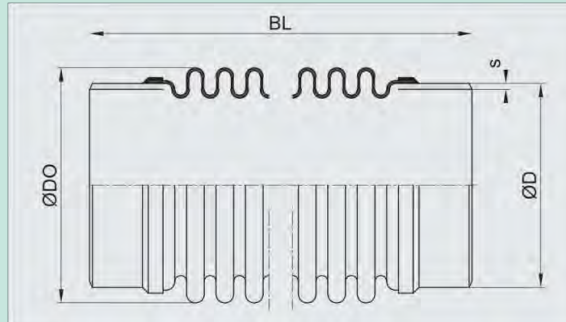

**barg (PN 10)**  
**10 barg (PN 10)**

DN	Länge Length		Balg Bellow		Anschweißenden Weld ends			Bewegungsaufnahm Movement			rstellkraftrate Springrate			Gewicht Weight	Artikel Article	
	BL mm	mm	ØDO	WF* cm <sup>2</sup>	mm	ØD	s mm	mm	axial	lateral	angular	axial	lateral			angular
									2δN mm	2ΔN mm	2αN °/deg.	Cδ N/mm	CΔ N/mm			Cα Nn/deg.
25	185		40		9	33,7	2,6		12	9	40	111	35	0,3	0,3	210-10-012-0025
32	175		50		14	42,4	2,6		15	8	41	86	55	0,4	0,5	210-10-015-0032
40	225		55		17	48,3	2,6		19	16	46	118	32	0,6	0,5	210-10-019-0040
50	195		69		28	60,3	2,9		18	9	34	115	96	0,9	0,7	210-10-018-0050
50	265		69		28	60,3	2,9		31	28	50	112	28	0,9	1,1	210-10-031-0050
65	205		87		46	76,1	2,9		25	11	37	83	94	1,1	0,8	210-10-025-0065
65	260		86		45	76,1	2,9		36	25	50	103	46	1,3	1,2	210-10-036-0065
80	165		114		79	88,9	3,2		23	5	26	83	359	1,9	1,2	210-10-023-0080
80	195		114		78	88,9	3,2		33	11	37	97	196	2,2	1,4	210-10-033-0080
80	275		113		77	88,9	3,2		46	29	50	129	72	2,8	2,3	210-10-046-0080
100	165		144		130	114,3	3,6		30	5	26	56	433	2,1	1,5	210-10-030-0100
100	205		141		126	114,3	3,6		43	13	39	78	211	2,8	2,3	210-10-043-0100
100	295		140		122	114,3	3,6		57	32	50	154	111	5,2	4,3	210-10-057-0100
125	165		170		187	139,7	4,0		30	4	22	66	725	3,4	1,9	210-10-030-0125
125	205		168		183	139,7	4,0		45	11	33	81	324	4,1	2,8	210-10-045-0125
125	280		169		181	139,7	4,0		63	27	47	139	180	7,0	5,4	210-10-063-0125
150	160		203		268	168,3	4,5		28	3	17	139	2490	11,0	3,2	210-10-028-0150
150	245		206		270	168,3	4,5		61	17	37	102	309	7,6	4,3	210-10-061-0150
150	340		198		256	168,3	4,5		71	33	45	180	179	13,0	5,9	210-10-071-0150
200	180		257		437	219,1	6,3		35	4	17	204	3310	25,0	6,1	210-10-035-0200
200	225		262		446	219,1	6,3		67	13	32	90	659	12,0	6,5	210-10-067-0200
200	290		259		435	219,1	6,3		91	26	44	137	415	17,0	11,3	210-10-091-0200
250	180		313		667	273,0	6,3		35	3	13	228	5670	43,0	6,8	210-10-035-0250
250	225		317		677	273,0	6,3		65	10	25	108	1200	21,0	8,1	210-10-065-0250

## Typ 210 Abmessungen Ausführung 1

### Type 210 Specifications

250	310	313	659	273,0	6,3	95	24	37	159	590	30,0	15,8	210-10-095-0250
300	180	368	932	323,9	7,1	39	3	12	201	7350	52,0	10,3	210-10-039-0300
300	265	370	933	323,9	7,1	91	16	30	118	1050	31,0	13,5	210-10-091-0300
300	335	373	930	323,9	7,1	115	28	38	177	751	46,0	22,8	210-10-115-0300
350	200	399	1110	355,6	6,3	37	2	11	233	9950	72,0	11,8	210-10-037-0350
350	250	407	1129	355,6	6,3	82	10	24	119	2230	38,0	17,0	210-10-082-0350
350	325	400	1103	355,6	6,3	106	21	32	151	1020	47,0	21,8	210-10-106-0350
400	200	459	1459	406,4	6,3	47	3	12	256	15500	104,0	15,5	210-10-047-0400
400	320	459	1461	406,4	6,3	93	15	24	144	1320	59,0	20,6	210-10-093-0400
400	385	458	1443	406,4	6,3	123	27	32	211	1080	85,0	32,6	210-10-123-0400
450	240	508	1818	457,0	8,8	66	6	15	211	7140	107,0	23,0	210-10-066-0450
450	305	515	1838	457,0	8,8	101	14	23	182	2580	93,0	31,4	210-10-101-0450
450	435	515	1822	457,0	8,8	143	34	34	244	1110	124,0	54,1	210-10-143-0450
500	200	562	2236	508,0	8,8	39	2	8	435	38700	270,0	23,0	210-10-039-0500
500	280	568	2254	508,0	8,8	96	10	20	202	4820	126,0	31,8	210-10-096-0500
500	395	569	2249	508,0	8,8	141	26	30	210	1620	131,0	44,5	210-10-141-0500
600	215	660	3147	610,0	8,0	42	2	7	643	54100	562,0	26,3	210-10-042-0600
600	315	669	3183	610,0	8,0	106	11	19	253	5570	224,0	36,8	210-10-106-0600
600	495	678	3208	610,0	8,0	175	37	31	266	1520	237,0	70,9	210-10-175-0600
700	270	772	4280	711,0	8,0	62	3	9	488	30900	580,0	33,9	210-10-062-0700
700	365	772	4280	711,0	8,0	109	12	16	279	5980	331,0	50,0	210-10-109-0700
700	480	784	4327	711,0	8,0	183	30	28	246	2400	296,0	72,1	210-10-183-0700

\*WF = wirksame Fläche / effective area

Weitere Abmessungen und Werkstoffe auf Anfrage. /  
Other dimensions and materials on request.

**Typ 210 Abmessungen  
Ausführung 1**

**Type 210 Specifications**

**Model 1**

**Druckstufe 16  
Design pressure**

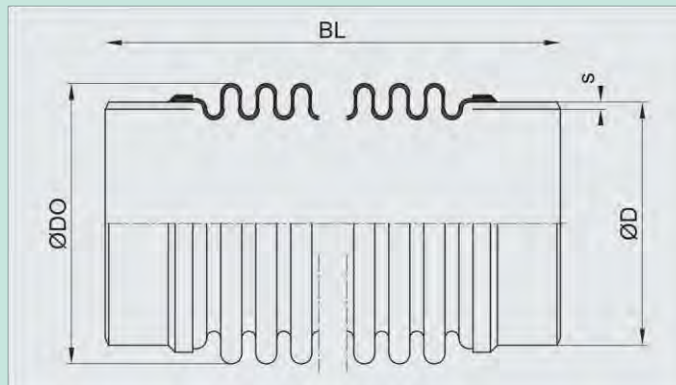

**barg (PN 16)  
16 barg (PN 16)**

DN	Länge Length	Balg Bellows			Anschweißenden Weld ends			wegungsaufnah Movement			stellkraftrate Springrate			Gewicht Weight	Artikel Article
		BL mm	ØDO cm <sup>2</sup>	WF* mm	ØD mm	s mm	axial 2δN mm	lateral 2λN mm	angular 2αN °/deg.	axial Cδ N/mm	ateral Cλ N/mm	angular Cα Nn/deg.	kg		
25	185	40	9	33,7	2,6	12	9	40	111	35	0,3	0,3	210-16-012-0025		
32	175	50	14	42,4	2,6	15	8	41	86	55	0,4	0,5	210-16-015-0032		
40	235	55	17	48,3	2,6	18	16	44	195	45	1,0	0,6	210-16-018-0040		
50	195	69	28	60,3	2,9	18	9	34	115	96	0,9	0,7	210-16-018-0050		
50	275	68	27	60,3	2,9	28	27	50	194	41	1,5	1,3	210-16-028-0050		
65	195	86	45	76,1	2,9	20	8	30	109	150	1,4	0,9	210-16-020-0065		
65	270	87	45	76,1	2,9	37	27	50	178	70	2,3	1,6	210-16-037-0065		
80	170	113	79	88,9	3,2	21	5	24	93	326	2,1	1,2	210-16-021-0080		
80	245	112	75	88,9	3,2	40	21	47	170	136	3,6	2,3	210-16-040-0080		
100	170	143	128	114,3	3,6	29	5	26	95	595	3,4	2,0	210-16-029-0100		
100	215	141	123	114,3	3,6	43	14	39	139	307	4,8	3,1	210-16-043-0100		
125	155	170	186	139,7	4,0	19	2	14	175	2390	9,0	2,3	210-16-019-0125		
125	195	173	187	139,7	4,0	40	9	29	124	625	6,5	3,0	210-16-040-0125		
125	230	172	184	139,7	4,0	50	15	37	146	380	7,5	4,7	210-16-050-0125		
150	165	205	269	168,3	4,5	24	3	14	247	3670	19,0	3,7	210-16-024-0150		
150	195	208	273	168,3	4,5	40	7	24	131	950	9,9	3,7	210-16-040-0150		
150	255	206	265	168,3	4,5	63	19	39	178	469	14,0	6,9	210-16-063-0150		



## Typ 210 Abmessungen Ausführung 1

### Type 210 Specifications

200	165	261	442	219,1	6,3	32	3	15	258	6880	32,0	6,9	210-16-032-0200
200	230	259	438	219,1	6,3	60	12	29	149	948	18,0	8,6	210-16-060-0200
200	320	257	427	219,1	6,3	75	25	36	266	540	32,0	14,9	210-16-075-0200
250	195	309	658	273,0	6,3	34	4	13	257	4410	47,0	8,1	210-16-034-0250
250	230	314	666	273,0	6,3	59	9	23	177	1710	33,0	10,8	210-16-059-0250
250	340	312	652	273,0	6,3	80	24	31	292	755	53,0	18,7	210-16-080-0250
300	165	365	919	323,9	7,1	28	1	9	409	21600	105,0	11,1	210-16-028-0300
300	220	370	928	323,9	7,1	63	8	21	210	3470	54,0	15,4	210-16-063-0300
300	320	369	920	323,9	7,1	89	20	29	244	1100	63,0	20,4	210-16-089-0300
350	205	396	1096	355,6	8,0	34	2	10	380	13900	116,0	12,9	210-16-034-0350
350	240	401	1106	355,6	8,0	60	7	18	242	4670	75,0	19,1	210-16-060-0350
350	335	402	1103	355,6	8,0	90	19	27	249	1440	77,0	30,2	210-16-090-0350
400	225	458	1451	406,4	8,8	45	4	12	405	13000	163,0	22,9	210-16-045-0400
400	290	457	1447	406,4	8,8	71	10	18	268	3240	108,0	25,4	210-16-071-0400
400	315	462	1457	406,4	8,8	97	16	25	227	2220	92,0	32,2	210-16-097-0400
450	225	507	1808	457,0	8,8	42	3	10	501	19500	252,0	25,8	210-16-042-0450
450	290	507	1808	457,0	8,8	68	8	16	314	4670	158,0	28,6	210-16-068-0450
450	315	513	1822	457,0	8,8	95	14	22	251	3060	127,0	36,3	210-16-095-0450
500	255	559	2217	508,0	8,8	49	4	10	559	15800	344,0	23,4	210-16-049-0500
500	310	559	2217	508,0	8,8	68	8	14	400	5740	246,0	31,8	210-16-068-0500
500	340	568	2245	508,0	8,8	103	15	22	276	3190	172,0	40,3	210-16-103-0500

\*WF = wirksame Fläche / effective area

Weitere Abmessungen und Werkstoffe auf Anfrage. /

Other dimensions and materials on request.

**Typ 210 Abmessungen**  
**Ausführung 1**

**Type 210 Specifications**

**Model 1**

**Druckstufe 25**  
**Design pressure**

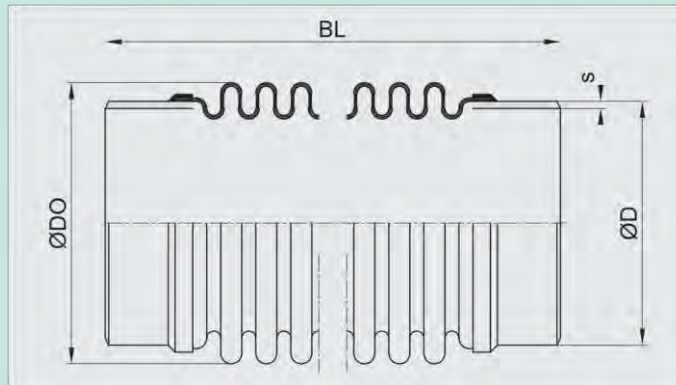

**barg (PN 25)**  
**25 barg (PN 25)**

DN	Länge Length	Balg Bellows			Anschweißenden Weld ends			wegungsaufnah Movement			stellkraftrate Springrate			Gewicht Weight	Artikel Article
		BL mm	ØDO mm	WF* cm <sup>2</sup>	mm	ØD mm	s mm	mm	axial 2δN mm	lateral 2λN mm	angular 2αN °/deg.	axial Cδ N/mm	ateral Cλ N/mm		
50	185	69	28	60,3	2,9	15	6	28	130	135	1,0	0,7	210-25-015-0050		
50	240	68	27	60,3	2,9	22	17	43	242	84	1,9	1,0	210-25-022-0050		
65	195	85	44	76,1	3,6	16	6	24	147	195	1,8	1,0	210-25-016-0065		
65	285	84	42	76,1	3,6	29	24	45	295	89	3,5	2,0	210-25-029-0065		
80	170	113	78	88,9	3,2	20	5	23	146	515	3,2	1,4	210-25-020-0080		
80	220	112	75	88,9	3,2	31	13	36	208	238	4,4	2,3	210-25-031-0080		
100	160	142	126	114,3	3,6	23	4	20	173	1400	6,0	2,3	210-25-023-0100		
100	215	138	120	114,3	3,6	36	12	33	198	401	6,6	2,6	210-25-036-0100		
125	185	170	184	139,7	4,0	28	5	21	187	1070	9,5	3,4	210-25-028-0125		
125	225	171	181	139,7	4,0	43	12	32	226	600	12,0	5,5	210-25-043-0125		
150	165	206	268	168,3	4,5	25	3	15	310	4530	24,0	4,5	210-25-025-0150		
150	240	203	261	168,3	4,5	47	13	29	257	782	19,0	6,9	210-25-047-0150		

## Typ 210 Abmessungen Ausführung 1

### Type 210 Specifications

200	170	257	431	219,1	6,3	27	2	13	436	9080	53,0	7,7	210-25-027-0200
200	220	259	435	219,1	6,3	51	9	24	215	1590	26,0	10,0	210-25-051-0200
200	285	257	427	219,1	6,3	60	17	29	319	908	38,0	13,3	210-25-060-0200
250	170	309	650	273,0	6,3	24	2	9	645	20200	117,0	9,7	210-25-024-0250
250	225	311	655	273,0	6,3	46	7	18	316	3110	58,0	12,5	210-25-046-0250
250	285	314	657	273,0	6,3	63	14	24	329	1450	60,0	16,6	210-25-063-0250
300	190	360	901	323,9	7,1	30	2	10	590	15300	148,0	13,4	210-25-030-0300
300	240	360	901	323,9	7,1	48	7	16	369	3850	93,0	15,4	210-25-048-0300
300	265	370	922	323,9	7,1	65	11	21	305	2450	79,0	20,4	210-25-065-0300
350	210	391	1076	355,6	8,0	28	2	8	691	21000	207,0	16,9	210-25-028-0350
350	260	391	1076	355,6	8,0	45	6	13	432	5390	129,0	19,1	210-25-045-0350
350	285	401	1100	355,6	8,0	62	9	18	353	3390	108,0	24,5	210-25-062-0350
400	210	450	1416	406,4	8,8	28	2	7	1020	39700	401,0	22,9	210-25-028-0400
400	255	452	1423	406,4	8,8	46	5	12	599	10700	237,0	21,3	210-25-046-0400
400	350	459	1441	406,4	8,8	82	15	21	399	2540	160,0	32,8	210-25-082-0400

\*WF = wirksame Fläche / effective area

Weitere Abmessungen und Werkstoffe auf Anfrage. /  
Other dimensions and materials on request.

Typ 210 Abmessungen  
Ausführung 1

Type 210 Specifications

Model 1

Druckstufe 40  
Design pressure

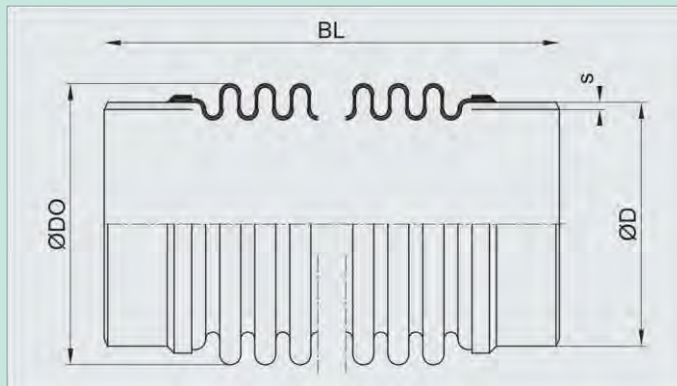

barg (PN 40)  
Ø barg (PN 40)

DN	Länge Length	Balg Bellows		Anschweißenden Weld ends		Bewegungsaufnahm Movement			Rückstellkraftrate Springrate			Gewicht Weight	Artikel Article
		BL mm	WF* cm <sup>2</sup>	mm	ØD mm	s mm	axial 2δN mm	lateral 2λN mm	angular 2αN %/deg.	axial Cδ N/mm	lateral Cλ N/mm		
50	200	69	28	60,3	2,9	13	5	25	240	303	1,9	0,8	210-40-013-0050
50	240	71	30	60,3	2,9	18	11	33	295	153	2,5	1,1	210-40-018-0050
65	215	85	44	76,1	3,6	15	6	23	234	324	2,9	1,2	210-40-015-0065
65	265	87	46	76,1	3,6	23	14	34	383	213	4,9	1,8	210-40-023-0065
80	195	111	75	88,9	3,2	18	4	21	269	795	5,6	1,6	210-40-018-0080
80	230	121	85	88,9	3,2	27	10	29	337	513	8,0	2,7	210-40-027-0080
100	205	139	123	114,3	3,6	20	5	18	271	977	9,2	2,3	210-40-020-0100
100	245	145	131	114,3	3,6	31	10	27	379	697	14,0	3,6	210-40-031-0100
125	210	167	178	139,7	4,0	24	5	18	340	1630	17,0	3,4	210-40-024-0125
125	245	173	190	139,7	4,0	33	9	24	345	913	19,0	4,5	210-40-033-0125
150	225	201	258	168,3	4,5	30	6	18	409	2140	30,0	5,3	210-40-030-0150
150	290	209	276	168,3	4,5	43	13	26	456	943	35,0	7,5	210-40-043-0150

## Typ 210 Abmessungen Ausführung 1

### Type 210 Specifications

200	250	254	422	219,1	6,3	35	7	17	574	3150	68,0	9,5	210-40-035-0200
200	285	262	451	219,1	6,3	45	11	21	458	1680	58,0	11,1	210-40-045-0200
250	250	310	648	273,0	6,3	36	5	14	629	5350	113,0	12,3	210-40-036-0250
250	315	322	691	273,0	6,3	52	12	20	560	2230	108,0	17,9	210-40-052-0250
300	255	367	909	323,9	7,1	38	5	12	791	8740	200,0	18,6	210-40-038-0300
300	335	373	948	323,9	7,1	55	12	18	588	2640	155,0	24,9	210-40-055-0300

\*WF = wirksame Fläche / effective area

Weitere Abmessungen und Werkstoffe auf Anfrage. /  
Other dimensions and materials on request.

## Axialkompensator mit drehbaren Losflanschen

### Typ 212

Der Typ 212 ist ein mehrlagiger Axialkompensator mit drehbaren Losflanschen, Er ist speziell konzipiert für den Betrieb in Anlagen mit Betriebsdrücken bis 63 barg.

Dieser Kompensator lässt sowohl axiale, laterale wie auch angulare Bewegungen zu.

#### Beschreibung

Neben den aufgeführten Standardbaulängen kann die Baulänge speziell auf Ihre Bedürfnisse angepasst gefertigt werden. Dieser Kompensator kann auch in anderen Werkstoffen (siehe Seite 179) gefertigt werden.

Die angegebenen Bewegungen stellen die einzelnen Maximalwerte dar. Zur Ermittlung kombinierter Bewegungsmöglichkeiten verwenden sie bitte das Bewegungsschaubild auf Seite 10.

#### Anforderungen

- Starke Festpunkte und gute Loslager erforderlich
- Große Bewegungen erfordern den Einsatz mehrerer Axialkompensatoren

#### Vorteile

- Einfache Lösung für die Kompensation von Temperaturschwankungen
- Keine Strömungsumlenkung
- Kompakte und platzsparende Lösung
- Relativ geringe Kosten



## Typ 213 (mit Innenleitrohr) Axial expansion joint with loose flanges

### Type 212

### Type 213 (with internal sleeve)

#### Description

In addition to the given standard lengths, other lengths are available to meet specific requirements. This expansion joint can also be produced in other materials (see page 179).

The specified movements represent the individual maximum values. For determining combined movements, refer to the movement diagram on page 10.

#### Requirements

- Strong fixed points and good floating bearings necessary
- Large movements require the use of several axial expansion joints

#### Advantages

- Simple solution for temperature fluctuation compensation
- No flow deflection
- Compact and space-saving solution
- Relatively low costs

## Axialkompensator mit drehbaren Losflanschen

### Typ 212

### Typ 213 (mit Innenleitrohr) WILLBRANDT Axial expansion joint with loose flanges

### Type 212

Type 212 is a multi-layer axial expansion joint with loose flanges. It is designed specifically for operation in installations with operating pressures up to 63 barg.

This expansion joint allows axial, lateral and angular movements.



**Einsatzbeispiele**

Flüssige, gasförmige oder Medien mit hohem Feststoffanteil (mit Innenleitrohr), z. B. Dampfanlagen, Wasser, Entwässerung, chemische Industrie, Petrochemie etc.

**Standardmäßiger Aufbau**

Mehrlagiger Wellrohrbalg aus 1.4541 mit glatten Flanschen aus C-Stahl (roh). Der Bördel besteht aus umgeformtem Balgmaterial.

**Zulässige Betriebsdaten (Standard)**

16 barg / 120 °C gem. EJMA  
Höhere Drücke auf Anfrage.

**Zubehör**

Innenleitrohr, Außenschutzrohr

**Hinweis**

Bei Verwendung von Leitrohren vermindert sich die Möglichkeit der Aufnahme der lateralen oder angularen Bewegungen um mind. 90 %. Bitte beachten Sie bei Ihrer Planung die Medienverträglichkeit der zu verwendenden Kompensatorenmaterialien.

**Application examples**

Liquid, gaseous or media with a high solids content (with internal sleeve), e.g. steam plants, water, drainage, chemical industry, petrochemistry, etc.

**Standard design**

Multi-layer corrugated tube bellows of 1.4541 with smooth flanges of carbon steel (raw). The collar is made from formed bellows material.

**Permissible operating data**

16 barg / 120 °C acco. to EJMA  
Higher pressures on request.

**Accessories**

Internal sleeve, external protective sleeve

**Note**

When using internal sleeves, the possibility to compensate for lateral or angular movements reduces by minimum 90 %. To be noted is that the media compatibility of the expansion joint material to be used should be taken into account in the planning phase.

**Typ 212 Abmessungen  
Ausführung 1**

**Type 212 Specifications  
Type 213 (with internal sleeve)**







Model 1

Druckstufe 2,5 barg (PN 2,5)  
Design pressure 2.5 barg (PN 2.5)

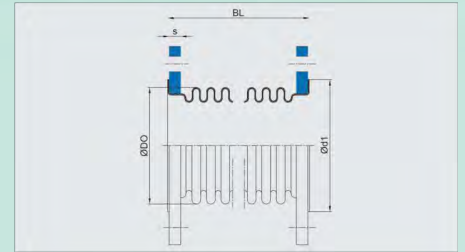

DN	Länge Length	Balg Bellow		Flansch Flanges		Bewegungsaufnahm Movement			Verstellkraftrate Springrate			Gewicht Weight	Artikel Article
						axial	lateral	angular	angular	axial	lateral		
	BL mm	ØDO cm <sup>2</sup>	WF* mm	Ød1 mm	s mm	2δN mm	2λN mm	e2αN %/deg.	Cδ N/mm	Cλ N/mm	Cα Nm/deg.	kg	
50	155	69	28	90	16	23	14	44	94	50	0,8	3,3	212-2,5-023-0050
50	220	69	28	90	16	38	39	50	58	12	0,5	3,4	212-2,5-038-0050
65	145	87	46	107	16	27	12	40	83	92	1,1	4,1	212-2,5-027-0065
65	200	87	46	107	16	43	30	50	52	24	0,7	4,3	212-2,5-043-0065
65	250	87	46	107	16	57	53	50	40	11	0,6	4,4	212-2,5-057-0065
80	150	114	79	122	18	26	6	29	83	328	1,9	6,4	212-2,5-026-0080
80	195	114	79	122	18	43	17	49	50	71	1,1	6,6	212-2,5-043-0080
80	250	114	79	122	18	65	39	50	33	22	0,8	6,7	212-2,5-065-0080
100	155	145	131	147	18	37	7	32	51	431	1,9	7,2	212-2,5-037-0100
100	190	144	130	147	18	53	15	47	38	129	1,4	7,4	212-2,5-053-0100
100	265	144	129	147	18	92	46	50	35	39	1,3	8,4	212-2,5-092-0100
125	160	171	188	178	20	38	6	28	60	730	3,1	9,5	212-2,5-038-0125
125	215	171	187	178	20	65	18	48	54	190	2,8	10,5	212-2,5-065-0125
125	305	172	186	178	20	97	50	50	61	59	3,1	12,2	212-2,5-097-0125
150	180	204	271	202	20	41	5	25	66	820	5,0	10,5	212-2,5-041-0150
150	250	204	271	202	20	83	24	50	33	111	2,5	11,1	212-2,5-083-0150
150	400	203	266	202	20	123	73	50	62	43	4,6	14,5	212-2,5-123-0150
200	185	257	442	258	22	57	7	27	52	824	6,3	15,4	212-2,5-057-0200
200	260	256	440	258	22	100	25	48	31	140	3,7	16,2	212-2,5-100-0200
200	310	259	444	258	22	114	37	50	42	109	5,2	17,6	212-2,5-114-0200
250	190	309	663	312	24	50	5	19	77	1710	15,0	19,8	212-2,5-050-0250
250	310	314	673	312	24	109	28	42	51	204	9,5	22,5	212-2,5-109-0250

## Typ 212 Abmessungen Ausführung 1

### Type 212 Specifications

250	405	313	667	312	24	149	56	50	60	114	12,0	28,0	212-2,5-149-0250
300	205	365	927	365	24	63	6	21	91	2960	24,0	27,4	212-2,5-063-0300
300	255	370	943	365	24	118	18	39	27	383	6,9	27,4	212-2,5-118-0300
300	420	365	923	365	24	159	53	50	62	147	16,0	35,9	212-2,5-159-0300
350	175	404	1132	410	26	54	3	16	50	3630	16,0	36,3	212-2,5-054-0350
350	250	402	1126	410	26	117	16	35	29	494	8,9	37,7	212-2,5-117-0350
350	405	400	1113	410	26	167	48	50	58	194	18,0	46,9	212-2,5-167-0350
400	230	461	1478	465	28	78	7	20	77	2710	32,0	44,7	212-2,5-078-0400
400	305	461	1478	465	28	130	20	34	46	569	19,0	46,7	212-2,5-130-0400
400	410	457	1459	465	28	183	45	48	58	281	24,0	54,9	212-2,5-183-0400
450	235	511	1842	520	30	74	6	17	90	3720	46,0	54,7	212-2,5-074-0450
450	305	511	1842	520	30	124	17	29	54	853	28,0	57,0	212-2,5-124-0450
450	415	510	1832	520	30	191	42	45	57	351	29,0	66,2	212-2,5-191-0450
500	255	566	2263	570	30	82	6	17	94	4230	59,0	59,1	212-2,5-082-0500
500	355	564	2254	570	30	140	20	29	58	755	36,0	61,6	212-2,5-140-0500
500	465	564	2248	570	30	211	46	45	61	356	38,0	71,7	212-2,5-211-0500
600	295	679	3257	670	32	75	5	13	167	9780	151,0	79,0	212-2,5-075-0600
600	385	679	3257	670	32	132	15	23	96	1920	87,0	82,8	212-2,5-132-0600
600	505	679	3257	670	32	207	38	36	61	493	55,0	88,6	212-2,5-207-0600
700	255	777	4335	775	24	73	4	11	195	16300	234,0	73,3	212-2,5-073-0700
700	345	778	4341	775	24	131	13	20	107	2970	129,0	77,7	212-2,5-131-0700
700	485	781	4358	775	24	220	35	33	60	695	73,0	84,4	212-2,5-220-0700
800	250	886	5654	880	37	62	2	8	219	46600	344,0	132,0	212-2,5-062-0800
800	340	886	5654	880	37	124	9	16	110	5680	172,0	137,0	212-2,5-124-0800
800	490	884	5640	880	37	219	31	29	65	967	101,0	144,0	212-2,5-219-0800
900	270	990	7110	980	37	63	2	7	225	61200	444,0	146,0	212-2,5-063-0900

900	360	990	7110	980	37	126	8	15	113	7450	222,0	151,0	212-2,5-126-0900
900	480	990	7110	980	37	211	24	25	68	1600	133,0	160,0	212-2,5-211-0900
1000	280	1096	8749	1080	42	66	2	7	214	74800	519,0	177,0	212-2,5-066-1000
1000	340	1098	8765	1080	42	115	5	12	120	14800	291,0	183,0	212-2,5-115-1000
1000	490	1093	8724	1080	42	211	22	22	72	2080	173,0	193,0	212-2,5-211-1000

**Typ 212 Abmessungen**  
**Ausführung 1**

**Type 212 Specifications**  
**Model 1**

**Druckstufe 2,5 barg (PN 2,5)**  
**Design pressure 2.5 barg (PN 2.5)**

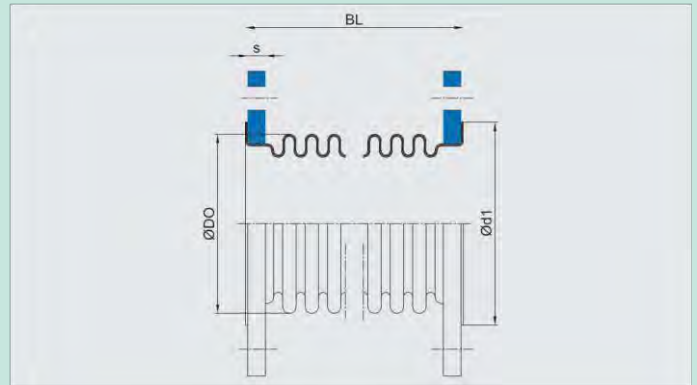

DN	Länge Length		Balg Bellow		Flansch Flanges		Bewegungsaufnahm Movement			Verstellkraft rate Spring rate			Gewicht Weight	Artikel Article
	BL mm	mm	ØDO cm <sup>2</sup>	WF* mm	Ød1 mm	s mm	axial 2ΔN mm	lateral 2ΔN mm	angular e 2αN °/deg.	Cδ N/mm	Cλ N/mm	Cα Nm/deg.		
1100	245		1180	10540	1180	20	84	3	8	187	42900	547,0	96,0	212-2,5-084-1100
1100	335		1180	10503	1180	20	137	9	13	124	8720	360,0	103,0	212-2,5-137-1100
1100	455		1180	10531	1180	20	228	23	22	71	2030	206,0	114,0	212-2,5-228-1100
1200	210		1280	11794	1280	42	80	2	7	212	49800	693,0	205,0	212-2,5-080-1200
1200	300		1280	11813	1280	42	136	8	12	131	10100	427,0	213,0	212-2,5-136-1200
1200	450		1280	11765	1280	42	211	22	19	92	2260	301,0	224,0	212-2,5-211-1200
1300	165		1366	13818	1366	20	62	1	5	283	141800	1090,0	108,0	212-2,5-062-1300
1300	225		1366	13818	1366	20	96	3	8	197	33700	753,0	112,0	212-2,5-096-1300
1300	345		1366	13797	1366	20	180	13	15	102	5500	388,0	125,0	212-2,5-180-1300
1400	225		1466	15980	1466	42	62	1	4	304	167000	1350,0	233,0	212-2,5-062-1400
1400	240		1466	15980	1466	42	96	3	7	211	42900	934,0	237,0	212-2,5-096-1400
1400	360		1466	15958	1466	42	179	12	14	109	6810	481,0	251,0	212-2,5-179-1400
1500	165		1566	18287	1566	20	60	1	4	336	218500	1710,0	124,0	212-2,5-060-1500
1500	225		1566	18299	1566	20	95	3	7	225	50900	1150,0	129,0	212-2,5-095-1500
1500	345		1566	18275	1566	20	178	11	13	116	8310	589,0	143,0	212-2,5-178-1500
1600	190		1666	20750	1666	47	59	1	4	370	283900	2140,0	324,0	212-2,5-059-1600
1600	250		1666	20776	1666	47	95	3	6	239	63000	1380,0	330,0	212-2,5-095-1600

## Typ 212 Abmessungen Ausführung 1

### Type 212 Specifications

1600	370	1666	20750	1666	47	178	10	12	124	10100	711,0	344,0	212-2,5-178-1600
1700	165	1766	23368	1766	20	58	1	3	407	329900	2640,0	140,0	212-2,5-058-1700
1700	225	1766	23409	1766	20	94	3	6	254	73000	1650,0	145,0	212-2,5-094-1700
1700	345	1766	23368	1766	20	174	10	11	136	12300	879,0	161,0	212-2,5-174-1700
1800	200	1866	26142	1866	52	56	1	3	445	416400	3240,0	399,0	212-2,5-056-1800
1800	260	1866	26199	1866	52	94	2	5	268	88400	1950,0	406,0	212-2,5-094-1800
1800	380	1866	26142	1866	52	170	9	10	149	15000	1080,0	422,0	212-2,5-170-1800
1900	165	1966	29117	1966	20	54	0	3	506	490600	4090,0	152,0	212-2,5-054-1900
1900	225	1966	29132	1966	20	92	2	5	293	103400	2370,0	161,0	212-2,5-092-1900
1900	345	1966	29132	1966	20	166	8	9	163	17800	1320,0	179,0	212-2,5-166-1900
2000	200	2066	32204	2066	52	53	0	3	552	612700	4940,0	441,0	212-2,5-053-2000
2000	260	2066	32204	2066	52	88	2	4	331	129300	2970,0	447,0	212-2,5-088-2000
2000	380	2066	32204	2066	52	159	7	9	184	22200	1650,0	466,0	212-2,5-159-2000
2100	170	2166	35449	2166	20	65	1	3	467	553100	4590,0	172,0	212-2,5-065-2100
2100	230	2166	35466	2166	20	111	2	5	269	119600	2650,0	184,0	212-2,5-111-2100
2100	350	2166	35483	2166	20	205	9	11	144	20700	1420,0	208,0	212-2,5-205-2100
2200	215	2266	38865	2266	57	65	0	3	487	633600	5260,0	575,0	212-2,5-065-2200
2200	275	2266	38865	2266	57	109	2	5	293	143800	3160,0	586,0	212-2,5-109-2200
2200	395	2266	38865	2266	57	197	8	10	163	25300	1760,0	609,0	212-2,5-197-2200

\*WF = wirksame Fläche / effective area

Weitere Abmessungen und Werkstoffe auf Anfrage. /  
Other dimensions and materials on request.

**Typ 212 Abmessungen  
Ausführung 1**

**Type 212 Specifications**

**Model 1**

**Druckstufe 6 barg  
Design pressure 6**

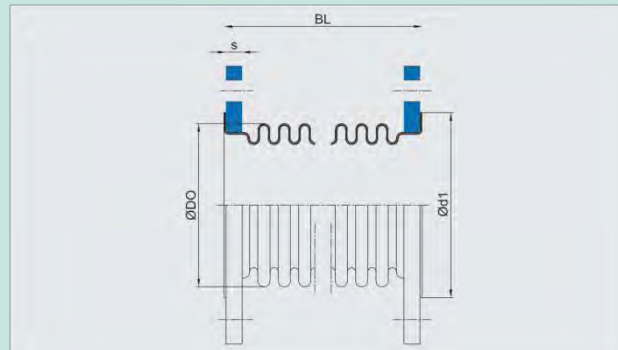

**(PN 6)  
barg (PN 6)**

DN	Länge Length	Balg Bellow		Flansch Flange		Bewegungsaufnahme Movement			Verstellkraftrate Springrate			Gewicht Weight	Artikel Article
		BL mm	WF* mm	Ød1 mm	s mm	axial 2δN mm	lateral 2ΔN mm	angular 2αN °/deg.	angular Cδ N/mm	axial Cλ N/mm	lateral Cα Nm/deg.		
50	155	69	28	90	16	23	14	44	94	50	0,8	3,3	212-06-023-0050
50	255	69	28	90	16	40	48	50	84	12	0,7	3,8	212-06-040-0050
65	145	87	46	107	16	26	11	38	83	91	1,1	4,1	212-06-026-0065
65	210	87	46	107	16	43	32	50	82	33	1,1	4,5	212-06-043-0065
80	150	114	79	122	18	25	6	28	83	325	1,9	6,4	212-06-025-0080
80	195	114	79	122	18	42	17	47	50	71	1,1	6,6	212-06-042-0080
80	260	114	77	122	18	59	37	50	78	46	1,7	7,5	212-06-059-0080
100	155	145	131	147	18	35	6	31	51	422	1,9	7,2	212-06-035-0100
100	200	144	129	147	18	53	15	47	58	164	2,1	7,8	212-06-053-0100
100	280	145	127	147	18	76	42	50	92	75	3,3	9,8	212-06-076-0100
125	160	171	188	178	20	35	5	25	60	706	3,1	9,5	212-06-035-0125
125	215	171	187	178	20	62	17	46	54	187	2,8	10,5	212-06-062-0125
125	310	170	182	178	20	82	43	50	104	92	5,3	13,4	212-06-082-0125
150	180	204	271	202	20	38	5	23	66	798	5,0	10,5	212-06-038-0150
150	255	204	267	202	20	65	20	40	107	278	8,0	12,6	212-06-065-0150
150	364	204	262	202	20	103	53	50	126	115	9,2	16,7	212-06-103-0150
200	185	257	442	258	22	51	6	24	52	784	6,3	15,4	212-06-051-0200
200	275	259	441	258	22	88	23	42	80	298	9,8	18,6	212-06-088-0200

## Typ 212 Abmessungen Ausführung 1

### Type 212 Specifications

200	330	259	435	258	22	110	38	50	116	253	14,0	23,1	212-06-110-0200
250	190	309	663	312	24	46	5	18	77	1660	15,0	19,8	212-06-046-0250
250	280	314	670	312	24	86	18	33	97	529	18,0	23,8	212-06-086-0250
250	375	310	656	312	24	111	37	44	119	261	22,0	28,6	212-06-111-0250
300	205	365	927	365	24	58	5	19	91	2840	24,0	27,4	212-06-058-0300
300	240	364	924	365	24	84	12	28	66	880	17,0	28,3	212-06-084-0300
300	305	370	933	365	24	115	24	38	98	636	26,0	34,9	212-06-115-0300
350	200	396	1104	410	26	55	4	16	106	3630	33,0	37,6	212-06-055-0350
350	245	398	1110	410	26	89	11	27	62	1010	19,0	39,6	212-06-089-0350
350	340	400	1108	410	26	123	27	37	104	576	32,0	47,8	212-06-123-0350
400	250	453	1451	465	28	65	7	17	104	2200	42,0	44,7	212-06-065-0400
400	315	458	1462	465	28	117	19	31	82	862	33,0	50,2	212-06-117-0400
400	460	455	1441	465	28	147	42	39	151	472	61,0	64,9	212-06-147-0400
450	235	510	1836	520	30	54	4	12	179	6670	91,0	56,2	212-06-054-0450
450	290	514	1851	520	30	90	11	21	97	1720	50,0	59,0	212-06-090-0450
450	420	513	1830	520	30	157	34	37	130	737	66,0	77,5	212-06-157-0450
500	260	568	2273	570	30	61	5	13	174	6550	110,0	60,7	212-06-061-0500
500	360	567	2269	570	30	108	16	23	102	1150	64,0	63,8	212-06-108-0500
500	460	569	2259	570	30	171	36	36	139	814	87,0	84,4	212-06-171-0500
600	305	666	3191	670	32	63	5	11	242	7900	214,0	79,0	212-06-063-0600
600	375	681	3256	670	32	131	16	23	133	2420	120,0	89,3	212-06-131-0600
600	480	679	3235	670	32	189	34	33	136	1140	123,0	108,0	212-06-189-0600
700	325	762	4248	775	40	57	4	8	312	12600	368,0	115,0	212-06-057-0700
700	390	776	4316	775	40	121	12	18	175	4120	209,0	127,0	212-06-121-0700
700	530	775	4298	775	40	195	33	30	156	1390	186,0	148,0	212-06-195-0700
800	305	878	5586	880	44	68	3	9	339	31500	526,0	160,0	212-06-068-0800

**Typ 212 Abmessungen  
Ausführung 1**

**Type 212 Specifications**

800	400	878	5586	880	44	119	11	16	194	5760	301,0	168,0	212-06-119-0800
800	500	885	5618	880	44	208	28	28	137	2160	214,0	192,0	212-06-212-0800
900	310	979	7011	980	48	65	3	7	389	46300	758,0	192,0	212-06-065-0900
900	405	980	7019	980	48	116	9	14	214	8210	416,0	200,0	212-06-116-0900
900	510	986	7047	980	48	199	24	24	157	2990	307,0	227,0	212-06-199-0900
1000	320	1080	8599	1080	52	62	2	6	443	61000	1060,0	223,0	212-06-062-1000
1000	415	1080	8599	1080	52	109	8	11	253	11400	605,0	233,0	212-06-109-1000
1000	535	1092	8679	1080	52	211	23	23	148	3650	355,0	263,0	212-06-211-1000
1200	285	1248	11652	1295	60	66	3	6	528	61100	1710,0	351,0	212-06-066-1200
1200	380	1251	11681	1295	60	114	8	10	288	13300	934,0	362,0	212-06-114-1200
1200	480	1263	11781	1295	60	214	22	20	172	4490	560,0	399,0	212-06-214-1200



**Typ 212 Abmessungen  
Ausführung 1**

**Type 212 Specifications**

**Model 1**

**Druckstufe 10 barg  
Design pressure 10**

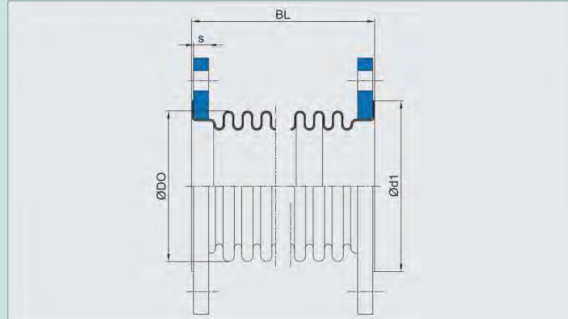

**(PN 10)  
barg (PN 10)**

DN	Länge Length	Balg Bellows		Flansch Flange		Bewegungsaufnahme Movement lateral			Verstellkraftrate Springrate			Gewicht Weight	Artikel Article
						axial	angular		angularaxiallateral				
							2ΔN mm	2αN	Cδ	Cλ	Cα		
	BL mm	ØDO cm <sup>2</sup>	WF* mm	Ød1 mm	s mm	25N mm	2αN °/deg.	N/mm	N/mm	Nm/deg.	kg		
25	115	40	9	68	16	12	9	40	111	37	0,3	2,4	212-10-012-0025
32	110	50	14	78	18	15	8	41	86	55	0,4	4,0	212-10-015-0032
40	155	55	17	88	18	19	16	46	118	32	0,6	4,5	212-10-019-0040
50	145	69	28	92	20	18	9	34	115	90	0,9	5,8	212-10-018-0050
50	210	69	28	92	20	31	28	50	112	29	0,9	6,2	212-10-031-0050
65	150	87	46	107	20	25	11	37	83	97	1,1	6,7	212-10-025-0065
65	210	86	45	107	20	35	24	50	103	44	1,3	7,1	212-10-035-0065
80	155	114	79	122	20	23	5	26	83	319	1,9	7,7	212-10-023-0080
80	180	114	78	122	20	33	11	37	97	204	2,2	8,0	212-10-033-0080
80	265	113	77	122	20	46	29	50	129	71	2,8	8,8	212-10-046-0080
100	155	144	130	147	22	30	5	26	56	433	2,1	9,5	212-10-030-0100
100	195	141	126	147	22	43	13	39	78	220	2,8	10,1	212-10-043-0100
100	295	140	122	147	22	57	32	50	154	105	5,2	12,1	212-10-057-0100
125	155	170	187	178	22	30	4	22	66	725	3,4	11,7	212-10-030-0125
125	195	168	183	178	22	45	11	33	81	338	4,1	12,3	212-10-045-0125
125	280	169	181	178	22	63	27	47	139	169	7,0	14,9	212-10-063-0125
150	165	203	268	208	24	28	3	17	139	2490	11,0	15,7	212-10-028-0150
150	250	206	270	208	24	61	17	37	102	316	7,6	17,4	212-10-061-0150

**Typ 212 Abmessungen  
Ausführung 1**

**Type 212 Specifications**

150	345	198	256	208	24	71	33	45	180	184	13,0	19,2	212-10-071-0150
200	185	257	437	258	24	35	4	17	204	3460	25,0	21,3	212-10-035-0200
200	230	262	446	258	24	67	13	32	90	659	12,0	22,5	212-10-067-0200
200	300	259	435	258	24	91	26	44	137	415	17,0	26,5	212-10-091-0200
250	190	313	667	320	26	35	3	13	228	5670	43,0	27,6	212-10-035-0250
250	235	317	677	320	26	65	10	25	108	1200	21,0	28,6	212-10-065-0250
250	325	313	659	320	26	95	24	37	159	577	30,0	35,3	212-10-095-0250
300	185	368	932	370	26	39	3	12	201	8140	52,0	32,0	212-10-039-0300
300	275	370	933	370	26	91	16	30	118	1080	31,0	36,7	212-10-091-0300
300	350	373	930	370	26	115	28	38	177	770	46,0	47,2	212-10-115-0300
350	195	399	1110	410	30	37	2	11	233	11000	72,0	49,0	212-10-037-0350
350	250	407	1129	410	30	82	10	24	119	2230	38,0	54,2	212-10-082-0350
350	330	400	1103	410	30	106	21	32	151	990	47,0	59,0	212-10-106-0350
400	210	459	1459	465	32	47	3	12	256	16300	104,0	63,0	212-10-047-0400
400	330	459	1461	465	32	93	15	24	144	1320	59,0	68,1	212-10-093-0400
400	400	458	1443	465	32	123	27	32	211	1090	85,0	80,1	212-10-123-0400
450	260	508	1818	520	36	66	6	15	211	6820	107,0	78,4	212-10-066-0450
450	330	515	1838	520	36	101	14	23	182	2450	93,0	86,8	212-10-101-0450
450	465	515	1822	520	36	143	34	34	244	1100	124,0	110,0	212-10-143-0450
500	235	562	2236	570	38	39	2	8	435	38700	270,0	90,5	212-10-039-0500
500	320	568	2254	570	38	96	10	20	202	4620	126,0	99,3	212-10-096-0500
500	435	569	2249	570	38	141	26	30	210	1620	131,0	112,0	212-10-141-0500
600	265	660	3147	670	37	42	2	7	643	48600	562,0	108,0	212-10-042-0600
600	365	669	3183	670	37	106	11	19	253	5480	224,0	119,0	212-10-106-0600
600	550	678	3208	670	37	175	37	31	266	1500	237,0	153,0	212-10-175-0600
700	310	772	4280	780	42	62	3	9	488	29900	580,0	160,0	212-10-062-0700

## Typ 212 Abmessungen Ausführung 1

### Type 212 Specifications

700	405	772	4280	780	42	109	12	16	279	5770	331,0	169,0	<b>212-10-109-0700</b>
700	525	784	4327	780	42	183	30	28	246	2400	296,0	205,0	<b>212-10-183-0700</b>

\*WF = wirksame Fläche / effective area

Weitere Abmessungen und Werkstoffe auf Anfrage. /  
Other dimensions and materials on request.

**Typ 212 Abmessungen  
Ausführung 1**

**Type 212 Specifications**

**Model 1**

**Druckstufe 16 barg  
Design pressure 16**

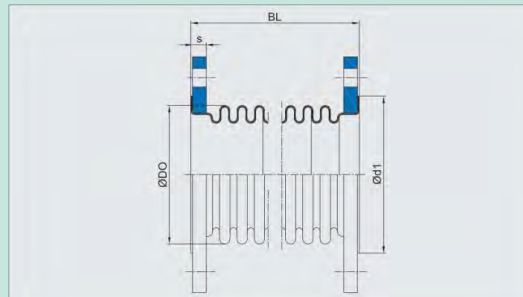

**(PN 16)  
barg (PN 16)**

e

DN	Länge Length	Balg Bellows		Flansch Flanges		Bewegungsaufnahm Movement			Verstellkraftrate Springrate			Gewicht Weight	Artikel Article
						axial	lateral	angular	angularaxiallateral				
									2δN mm	2λN mm	2αN %/deg.		
BL mm	ØDO cm <sup>2</sup>	WF* mm	Ød1 mm	s mm	mm	mm	mm	mm	mm	mm	mm	kg	
25	115	40	9	68	16	12	9	40	111	37	0,3	2,4	212-16-012-0025
32	110	50	14	78	18	15	8	41	86	55	0,4	4,0	212-16-015-0032
40	165	55	17	88	18	18	16	44	195	45	1,0	4,6	212-16-018-0040
50	145	69	28	92	20	18	9	34	115	90	0,9	5,8	212-16-018-0050
50	220	68	27	92	20	28	27	50	194	43	1,5	6,4	212-16-028-0050
65	145	86	45	107	20	20	8	30	109	141	1,4	6,7	212-16-020-0065
65	215	87	45	107	20	37	27	50	178	72	2,3	7,7	212-16-037-0065
80	155	113	79	122	20	21	5	24	93	349	2,1	7,7	212-16-021-0080
80	235	112	75	122	20	40	21	47	170	136	3,6	8,8	212-16-040-0080
100	160	143	128	147	22	29	5	26	95	623	3,4	9,8	212-16-029-0100
100	210	141	123	147	22	43	14	39	139	307	4,8	10,9	212-16-043-0100
125	150	170	186	178	22	19	2	14	175	2180	9,0	11,8	212-16-019-0125

\*WF = wirksame Fläche / effective area

Weitere Abmessungen und Werkstoffe auf Anfrage.  
Other dimensions and materials on request.

## Typ 212 Abmessungen Ausführung 1

### Type 212 Specifications

125	190	173	187	178	22	40	9	29	124		6,5	12,9	212-16-040-0125
125	225	172	184	178	22	50	15	37	146	380	7,5	14,2	212-16-050-0125
150	170	205	269	208	24	24	3	14	247	3670	19,0	16,2	212-16-024-0150
150	200	208	273	208	24	40	7	24	131	950	9,9	16,8	212-16-040-0150
150	265	206	265	208	24	63	19	39	178	469	14,0	19,4	212-16-063-0150
200	180	261	442	258	26	32	3	15	258	6260	32,0	21,7	212-16-032-0200
200	245	259	438	258	26	60	12	29	149	907	18,0	23,4	212-16-060-0200
200	340	257	427	258	26	75	25	36	266	521	32,0	29,7	212-16-075-0200
250	220	309	658	320	29	34	4	13	257	4410	47,0	30,4	212-16-034-0250
250	260	314	666	320	29	59	9	23	177	1640	33,0	33,1	212-16-059-0250
250	360	312	652	320	29	80	24	31	292	782	53,0	41,0	212-16-080-0250
300	200	365	919	375	32	28	1	9	409	20600	105,0	40,6	212-16-028-0300
300	255	370	928	375	32	63	8	21	210	3560	54,0	44,9	212-16-063-0300
300	345	369	920	375	32	89	20	29	244	1150	63,0	55,0	212-16-089-0300
350	215	396	1096	410	35	34	2	10	380	13900	116,0	59,0	212-16-034-0350
350	250	401	1106	410	35	60	7	18	242	4910	75,0	63,8	212-16-060-0350
350	350	402	1103	410	35	90	19	27	249	1440	77,0	74,9	212-16-090-0350
400	250	458	1451	465	38	45	4	12	405	13000	163,0	80,2	212-16-045-0400
400	315	457	1447	465	38	71	10	18	268	3310	108,0	82,7	212-16-071-0400
400	345	462	1457	465	38	97	16	25	227	2170	92,0	89,5	212-16-097-0400
450	260	507	1808	520	42	42	3	10	501	19500	252,0	102,0	212-16-042-0450
450	320	507	1808	520	42	68	8	16	314	4970	158,0	105,0	212-16-068-0450
450	355	513	1822	520	42	95	14	22	251	2920	127,0	113,0	212-16-095-0450
500	310	559	2217	570	46	49	4	10	559	15800	344,0	138,0	212-16-049-0500
500	365	559	2217	570	46	68	8	14	400	5640	246,0	142,0	212-16-068-0500
500	400	568	2245	570	46	103	15	22	276	3070	172,0	150,0	212-16-103-0500

Model 1

Druckstufe 25 barg (PN 25)  
Design pressure 25 barg (PN 25)

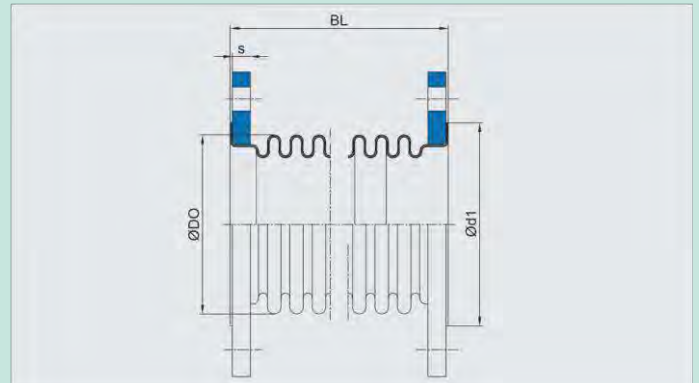

DN	Länge Length	Balg Bellows		Flansch Flanges		Bewegungsaufnahme Movement			Herstellkraft Springrate			Gewicht Weight	Artikel Article
		BL mm	ØDO cm <sup>2</sup>	WF* mm	Ød1 mm	s mm	axial 2δN mm	lateral 2ΔN mm	angular 2αN °/deg.	Cδ N/mm	CΔ N/mm		
50	135	69	28	92	20	15	6	28	130	127	1,0	5,2	212-25-015-0050
50	190	68	27	92	20	22	17	43	242	80	1,9	5,6	212-25-022-0050
65	140	85	44	107	22	16	6	24	147	217	1,8	6,7	212-25-016-0065
65	235	84	42	107	22	29	24	45	295	89	3,5	7,7	212-25-029-0065
80	165	113	78	122	24	20	5	23	146	515	3,2	8,7	212-25-020-0080
80	215	112	75	122	24	31	13	36	208	253	4,4	9,6	212-25-031-0080
100	165	142	126	147	26	23	4	20	173	1240	6,0	12,5	212-25-023-0100
100	220	138	120	147	26	36	12	33	198	388	6,6	13,3	212-25-036-0100
125	190	170	184	178	28	28	5	21	187	1070	9,5	17,3	212-25-028-0125

## Typ 212 Abmessungen Ausführung 1

### Type 212 Specifications

125	235	171	181	178	28	43	12	32	226	600	12,0	19,4	212-25-043-0125
150	195	206	268	208	30	25	3	15	310	4530	24,0	21,9	212-25-025-0150
150	265	203	261	208	30	47	13	29	257	743	19,0	24,3	212-25-047-0150
200	195	257	431	258	32	27	2	13	436	9430	53,0	31,3	212-25-027-0200
200	250	259	435	258	32	51	9	24	215	1460	26,0	33,6	212-25-051-0200
200	315	257	427	258	32	60	17	29	319	892	38,0	36,9	212-25-060-0200
250	205	309	650	320	35	24	2	9	645	17600	117,0	43,8	212-25-024-0250
250	255	311	655	320	35	46	7	18	316	3230	58,0	46,6	212-25-046-0250
250	330	314	657	320	35	63	14	24	329	1450	60,0	50,7	212-25-063-0250
300	225	360	901	375	38	30	2	10	590	16400	148,0	57,9	212-25-030-0300
300	280	360	901	375	38	48	7	16	369	3790	93,0	59,9	212-25-048-0300
300	305	370	922	375	38	65	11	21	305	2500	79,0	64,9	212-25-065-0300
350	235	391	1076	410	42	28	2	8	691	21000	207,0	87,9	212-25-028-0350
350	285	391	1076	410	42	45	6	13	432	5480	129,0	90,1	212-25-045-0350
350	315	401	1100	410	42	62	9	18	353	3320	108,0	95,5	212-25-062-0350
400	260	450	1416	465	48	28	2	7	1020	39700	401,0	123,0	212-25-028-0400
400	300	452	1423	465	48	46	5	12	599	11500	237,0	126,0	212-25-046-0400
400	400	459	1441	465	48	82	15	21	399	2590	160,0	140,0	212-25-082-0400

\*WF = wirksame Fläche / effective area

Weitere Abmessungen und Werkstoffe auf Anfrage. /  
Other dimensions and materials on request.

## Axialkompensator mit Festflanschen

### Typ 214

### Typ 215 (mit Innenleitrohr)

Der Typ 214 ist ein mehrlagiger Axialkompensator mit Festflanschen, Er ist speziell konzipiert für den Betrieb in Anlagen mit Betriebsdrücken bis max. 63 barg.

Dieser Kompensator lässt sowohl axiale, laterale wie auch angulare Bewegungen zu.

#### Beschreibung

Neben den aufgeführten Standardbaulängen kann er speziell auf Ihre Bedürfnisse angepasst gefertigt werden. Dieser Kompensator kann auch in anderen Werkstoffen (siehe Seite 179) gefertigt werden.

Die angegebenen Bewegungen stellen die einzelnen Maximalwerte dar. Zur Ermittlung kombinierter Bewegungsmöglichkeiten verwenden Sie bitte das Bewegungsschaubild auf Seite 10.

#### Anforderungen

- Starke Festpunkte und gute Loslager erforderlich
- Große Bewegungen erfordern den Einsatz mehrerer Axialkompensatoren
- Für lange Rohrleitungsabschnitte werden viele Festpunkte und Loslager benötigt
- Höhere Kosten für Festpunkte und Loslager

#### Vorteile

- Einfache Lösung für die Kompensation von Temperaturschwankungen
- Keine Strömungsumlenkung
- Kompakte und platzsparende Lösung
- Relativ geringe Kosten
- 



### Typ 214

### Typ 215 (with internal sleeve)

This expansion joint allows axial, lateral and angular movements.

#### Description

In addition to the given standard lengths, other lengths are available to meet specific requirements. This expansion joint can also be produced in other materials (see page 179).

The specified movements represent the individual maximum values. For determining combined movements, refer to the movement diagram on page 10.

#### Requirements

- Strong fixed points and good floating bearings necessary
- Large movements require the use of several axial expansion joints
- For long sections of pipeline, numerous fixed points and floating bearings are required ▫ Higher costs for fixed points and floating bearings

#### Advantages

- Simple solution for temperature fluctuation compensation
- No flow deflection
- Compact and space-saving solution
- Relatively low costs

Type 214 is a multi-layer axial expansion joint with fixed flanges. It is designed specifically for operation in installations with operating pressures up to 63 barg.



## Axialkompensator mit Festflanschen

### Typ 214

### Typ 215 (mit Innenleitrohr)

### Type 214

### Type 215 (with internal sleeve)

**Einsatzbeispiele** Flüssige, gasförmige oder Medien mit hohem Feststoffanteil (mit Innenleitrohr) z. B. Dampfanlagen, Wasser, Entwässerung, chemische Industrie, Petrochemie etc.

**Standardmäßiger Aufbau** Mehrlagiger Wellrohrbalg aus 1.4541 mit glatten Flanschen aus C-Stahl (roh).

**Zulässige Betriebsdaten** (Standard) 16 barg / 120 °C gem. EJMA  
Höhere Drücke auf Anfrage.

**Zubehör** Innenleitrohr, Außenschutzrohr

**Hinweis** Bei Verwendung von Leitrohren vermindert sich die Möglichkeit der Aufnahme der lateralen oder angularen Bewegungen um mind. 90 %. Bitte beachten Sie bei Ihrer Planung die Medienverträglichkeit der zu verwendenden Kompensatorenmaterialien.

**Application examples** Liquid, gaseous or media with a high solids content (with internal sleeve), e.g. steam plants, water, drainage, chemical industry, petrochemistry, etc.

**Standard design** Single layer corrugated tube bellows of 1.4541 with smooth flanges of carbon steel (raw).

**Permissible operating data** 16 barg / 120 °C acc. to EJMA  
Higher pressures on request.

**Accessories** Internal sleeve, external protective sleeve

**Note** When using internal sleeves, the possibility to compensate for lateral or angular movements reduces by minimum 90 %. To be noted is that the media compatibility of the expansion joint material to be used should be taken into account in the planning phase.

Model 1

Druckstufe 2,5 barg (PN 2,5)  
Design pressure 2.5 barg (PN 2.5)

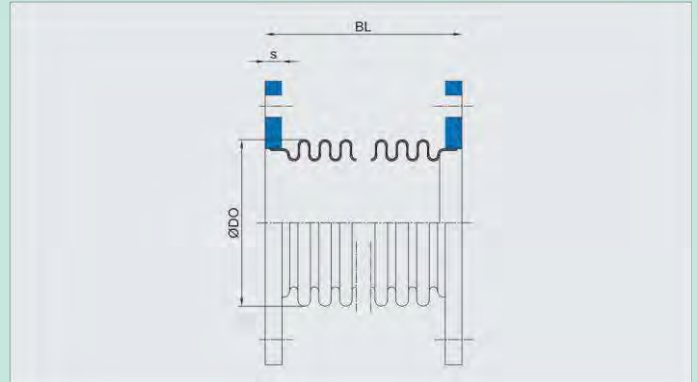

DN	Länge Length BL mm	Balg Bellow			Flansch Flanges s mm	Bewegungsaufnahm Movement			rstellkraftrate Springrate			Gewicht Weight kg	Artikel Article
		ØDO	WF* cm <sup>2</sup>	mm		axial 2δN mm	lateral 2ΔN mm	angular e 2αN °/deg.	axial CδVe N/mm	lateral Cλ N/mm	angular Cα Nn/deg.		
50	145	69	28	16	23	14	44	94	53	0,8	3,3	214-2,5-023-0050	
50	215	69	28	16	38	39	50	58	12	0,5	3,4	214-2,5-038-0050	
65	135	87	46	16	27	12	40	83	98	1,1	4,0	214-2,5-027-0065	
65	205	87	46	16	43	32	50	82	32	1,1	4,5	214-2,5-043-0065	
80	130	114	79	18	26	6	29	83	315	1,9	6,4	214-2,5-026-0080	
80	170	114	79	18	43	17	49	50	77	1,1	6,6	214-2,5-043-0080	
80	230	114	79	18	65	39	50	33	22	0,8	6,7	214-2,5-065-0080	
100	135	145	131	18	37	7	32	51	431	1,9	7,2	214-2,5-037-0100	
100	170	144	130	18	53	15	47	38	129	1,4	7,3	214-2,5-053-0100	
100	245	144	129	18	92	46	50	35	38	1,3	8,4	214-2,5-092-0100	
125	140	171	188	20	38	6	28	60	690	3,1	9,5	214-2,5-038-0125	
125	190	171	187	20	65	18	48	54	205	2,8	10,1	214-2,5-065-0125	
125	285	172	186	20	97	50	50	61	58	3,1	12,2	214-2,5-097-0125	
150	155	204	271	20	41	5	25	66	897	5,0	10,5	214-2,5-041-0150	
150	230	204	271	20	83	24	50	33	108	2,5	11,1	214-2,5-083-0150	
150	380	203	266	20	123	73	50	62	42	4,6	14,5	214-2,5-123-0150	
200	165	257	442	22	57	7	27	52	824	6,3	15,1	214-2,5-057-0200	
200	250	259	441	22	92	24	44	80	318	9,8	18,6	214-2,5-092-0200	

## Typ 214 Abmessungen Ausführung 1

### Type 214 Specifications

200	285	259	444	22	114	37	50	42	113	5,2	17,6	214-2,5-114-0200
250	170	309	663	24	50	5	19	77	1640	15,0	19,8	214-2,5-050-0250
250	290	314	673	24	109	28	42	51	202	9,5	22,5	214-2,5-109-0250
250	380	313	667	24	149	56	50	60	115	12,0	28,0	214-2,5-149-0250
300	185	365	927	24	63	6	21	91	2810	24,0	26,9	214-2,5-063-0300
300	235	370	943	24	118	18	39	27	383	6,9	27,4	214-2,5-118-0300
300	395	365	923	24	159	53	50	62	149	16,0	35,9	214-2,5-159-0300
350	155	404	1132	26	54	3	16	50	3630	16,0	35,9	214-2,5-054-0350
350	230	402	1126	26	117	16	35	29	478	8,9	37,7	214-2,5-117-0350
350	385	400	1113	26	167	48	50	58	191	18,0	46,9	214-2,5-167-0350
400	210	461	1478	28	78	7	20	77	2560	32,0	44,7	214-2,5-078-0400
400	280	461	1478	28	130	20	34	46	604	19,0	46,7	214-2,5-130-0400
400	390	457	1459	28	183	45	48	58	274	24,0	54,9	214-2,5-183-0400
450	210	511	1842	30	74	6	17	90	4060	46,0	54,7	214-2,5-074-0450
450	285	511	1842	30	124	17	29	54	853	28,0	57,0	214-2,5-124-0450
450	390	510	1832	30	191	42	45	57	360	29,0	66,2	214-2,5-191-0450
500	235	566	2263	30	82	6	17	94	4130	59,0	57,8	214-2,5-082-0500
500	330	564	2254	30	140	20	29	58	772	36,0	61,6	214-2,5-140-0500
500	440	564	2248	30	211	46	45	61	364	38,0	71,7	214-2,5-211-0500
600	270	679	3257	32	75	5	13	167	10500	151,0	79,0	214-2,5-075-0600
600	360	679	3257	32	132	15	23	96	1960	87,0	82,8	214-2,5-132-0600
600	480	679	3257	32	207	38	36	61	503	55,0	88,6	214-2,5-207-0600
700	235	777	4335	24	73	4	11	195	15700	234,0	71,1	214-2,5-073-0700
700	325	778	4341	24	131	13	20	107	2910	129,0	75,5	214-2,5-131-0700
700	465	781	4358	24	220	35	33	60	678	73,0	84,4	214-2,5-220-0700
800	230	886	5654	37	62	2	8	219	44300	344,0	132,0	214-2,5-062-0800

## Typ 214 Abmessungen Ausführung 1

### Type 214 Specifications

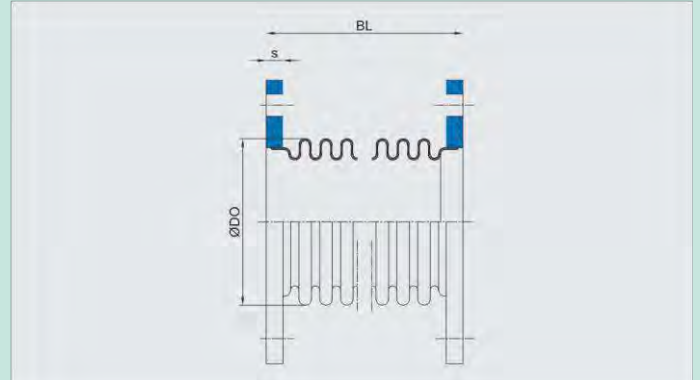

800	320	886	5654	37	124	9	16	110	5540	172,0	137,0	214-2,5-124-0800
800	470	884	5640	37	219	31	29	65	955	101,0	144,0	214-2,5-219-0800
900	250	990	7110	37	63	2	7	225	58100	444,0	146,0	214-2,5-063-0900
900	340	990	7110	37	126	8	15	113	7270	222,0	149,0	214-2,5-126-0900
900	460	990	7110	37	211	24	25	68	1580	133,0	160,0	214-2,5-211-0900

\*WF = wirksame Fläche / effective area

Weitere Abmessungen und Werkstoffe auf Anfrage. /  
Other dimensions and materials on request.

## Model 1

### Druckstufe 2,5 barg (PN 2,5)

## Typ 214 Abmessungen Ausführung 1

### Type 214 Specifications

e Ve

#### Design pressure 2.5 barg (PN 2.5)

DN	Länge Length	Balg Bellow		Flansch Flanges	Bewegungsaufnahm Movement lateral			rstellkraftrate Springrate lateral			Gewicht Weight	Artikel Article
		ØDO	WF* cm <sup>2</sup>		mm	s	axial 2ΔN mm	angular 2αN °/deg.	axial Cβ N/mm	Cλ N/mm		
1000	260	1096	8749	42	66	2	7	214	70700	519,0	177,0	214-2,5-066-1000
1000	320	1098	8765	42	115	5	12	120	14400	291,0	183,0	214-2,5-115-1000
1000	470	1093	8724	42	211	22	22	72	2050	173,0	193,0	214-2,5-211-1000
1200	235	1264	11794	42	80	2	7	212	52400	693,0	205,0	214-2,5-080-1200
1200	325	1264	11813	42	136	8	12	131	10100	427,0	213,0	214-2,5-136-1200
1200	480	1259	11765	42	211	22	19	92	2210	301,0	224,0	214-2,5-211-1200
1400	220	1466	15980	42	62	1	4	304	176000	1350,0	233,0	214-2,5-062-1400
1400	265	1464	15980	42	96	3	7	211	43900	934,0	237,0	214-2,5-096-1400
1400	385	1464	15958	42	179	12	14	109	6900	481,0	251,0	214-2,5-179-1400
1600	215	1664	20750	47	59	1	4	370	283900	2140,0	324,0	214-2,5-059-1600

## Typ 214 Abmessungen Ausführung 1

### Type 214 Specifications

1600	275	1664	20776	47	95	3	6	239	64500	1380,0	329,0	214-2,5-095-1600
1600	395	1664	20750	47	178	10	12	124	10200	711,0	344,0	214-2,5-178-1600
1800	225	1864	26142	52	56	1	3	445	416400	3240,0	396,0	214-2,5-056-1800
1800	285	1864	26199	52	94	2	5	268	90600	1950,0	404,0	214-2,5-094-1800
1800	405	1864	26142	52	170	9	10	149	15200	1080,0	422,0	214-2,5-170-1800
2000	225	2061	32204	52	53	0	3	552	612700	4940,0	441,0	214-2,5-053-2000
2000	285	2061	32204	52	88	2	4	331	132200	2970,0	447,0	214-2,5-088-2000
2000	405	2061	32204	52	159	7	9	184	22500	1650,0	466,0	214-2,5-159-2000
2200	240	2260	38865	57	65	0	3	487	633600	5260,0	572,0	214-2,5-065-2200
2200	300	2260	38865	57	109	2	5	293	143800	3160,0	584,0	214-2,5-109-2200
2200	420	2260	38865	57	197	8	10	163	25300	1760,0	609,0	214-2,5-197-2200

\*WF = wirksame Fläche / effective area

Weitere Abmessungen und Werkstoffe auf Anfrage. /  
Other dimensions and materials on request.

**Typ 214 Abmessungen  
Ausführung 1**

**Type 214 Specifications**

**Model 1**

**Druckstufe 6 barg  
Design pressure 6**

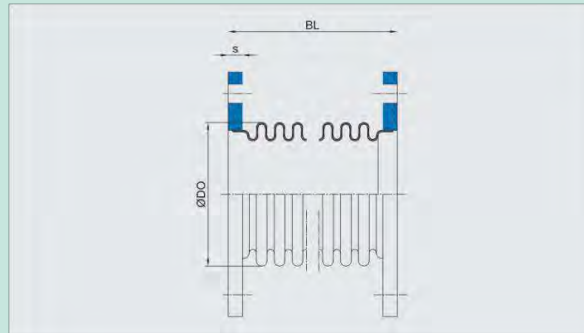

**(PN 6)  
barg (PN 6)**

DN	Länge Length	Balg Bellow			Flansch Flanges	Bewegungsaufnahm Movement lateral			Rückstellkraft Springrate			Gewicht Weight	Artikel Article
		BL mm	ØDO	WF* cm <sup>2</sup>		s mm	axial	angular	axial	lateral	angular		
							2ΔN mm	2αN %/deg.	Cδ N/mm	Cλ N/mm	Cα Nn/deg.		
50	145	69	28	16	23	14	44	94	53	0,8	3,3	214-06-023-0050	
50	245	69	28	16	41	49	50	84	13	0,7	3,7	214-06-041-0050	
65	135	87	46	16	26	11	38	83	98	1,1	4,0	214-06-026-0065	
65	205	87	46	16	43	32	50	82	32	1,1	4,5	214-06-043-0065	
80	130	114	79	18	25	6	28	83	313	1,9	6,4	214-06-025-0080	
80	170	114	79	18	42	17	47	50	76	1,1	6,6	214-06-042-0080	
80	235	114	77	18	59	37	50	78	47	1,7	7,5	214-06-059-0080	
100	135	145	131	18	35	6	31	51	422	1,9	7,2	214-06-035-0100	
100	175	144	129	18	53	15	47	58	176	2,1	7,8	214-06-053-0100	
100	260	145	127	18	76	42	50	92	72	3,3	9,8	214-06-076-0100	
125	140	171	188	20	35	5	25	60	669	3,1	9,5	214-06-035-0125	
125	190	171	187	20	62	17	46	54	201	2,8	10,1	214-06-062-0125	
125	290	170	182	20	82	43	50	104	90	5,3	12,7	214-06-082-0125	
150	155	204	271	20	38	5	23	66	872	5,0	10,5	214-06-038-0150	
150	235	204	267	20	65	20	40	107	267	8,0	12,6	214-06-065-0150	
150	340	204	262	20	103	53	50	126	115	9,2	16,7	214-06-103-0150	
200	165	257	442	22	51	6	24	52	784	6,3	15,1	214-06-051-0200	
200	250	259	441	22	88	23	42	80	313	9,8	18,6	214-06-088-0200	

## Typ 214 Abmessungen Ausführung 1

### Type 214 Specifications

200	305	259	435	22	110	38	50	116	259	14,0	23,1	214-06-110-0200
250	170	309	663	24	46	5	18	77	1590	15,0	19,8	214-06-046-0250
250	255	314	670	24	86	18	33	97	554	18,0	23,8	214-06-086-0250
250	350	310	656	24	111	37	44	119	266	22,0	28,6	214-06-111-0250
300	185	365	927	24	58	5	19	91	2700	24,0	26,9	214-06-058-0300
300	220	364	924	24	84	12	28	66	858	17,0	28,3	214-06-084-0300
300	280	370	933	24	115	24	38	98	644	26,0	34,9	214-06-115-0300
350	175	396	1104	26	55	4	16	106	4010	33,0	37,0	214-06-055-0350
350	220	398	1110	26	89	11	27	62	1100	19,0	39,6	214-06-089-0350
350	320	400	1108	26	123	27	37	104	561	32,0	45,9	214-06-123-0350
400	230	453	1451	28	65	7	17	104	2160	42,0	44,7	214-06-065-0400
400	290	458	1462	28	117	19	31	82	884	33,0	48,7	214-06-117-0400
400	440	455	1441	28	147	42	39	151	463	61,0	64,9	214-06-147-0400
450	215	510	1836	30	54	4	12	179	6340	91,0	56,2	214-06-054-0450
450	270	514	1851	30	90	11	21	97	1680	50,0	57,6	214-06-090-0450
450	395	513	1830	30	157	34	37	130	746	66,0	77,5	214-06-157-0450
500	235	568	2273	30	61	5	13	174	6850	110,0	60,7	214-06-061-0500
500	335	567	2269	30	108	16	23	102	1200	64,0	63,8	214-06-108-0500
500	435	569	2259	30	171	36	36	139	814	87,0	84,4	214-06-171-0500
600	285	666	3191	32	63	5	11	242	7780	214,0	79,0	214-06-063-0600
600	350	681	3256	32	131	16	23	133	2470	120,0	89,3	214-06-131-0600
600	455	679	3235	32	189	34	33	136	1170	123,0	99,9	214-06-189-0600
700	270	762	4248	24	57	4	8	312	12600	368,0	71,1	214-06-057-0700
700	335	776	4316	24	121	12	18	175	4120	209,0	85,3	214-06-121-0700
700	475	775	4298	24	195	33	30	156	1390	186,0	107,0	214-06-195-0700
800	265	878	5586	37	68	3	9	339	32800	526,0	134,0	214-06-068-0800



**Typ 214 Abmessungen**  
**Ausführung 1**

**Type 214 Specifications**

800	360	878	5586	37	119	11	16	194	5990	301,0	142,0	214-06-119-0800
800	465	885	5618	37	208	28	28	137	2110	214,0	169,0	214-06-208-0800
900	265	979	7011	37	65	3	7	389	46300	758,0	149,0	214-06-065-0900
900	360	980	7019	37	116	9	14	214	8210	416,0	157,0	214-06-116-0900
900	465	986	7047	37	199	24	24	157	2960	307,0	188,0	214-06-199-0900
1000	280	1080	8599	42	62	2	6	443	58700	1060,0	185,0	214-06-062-1000
1000	370	1080	8599	42	109	8	11	253	11700	605,0	194,0	214-06-109-1000
1000	490	1092	8679	42	211	23	23	148	3650	355,0	224,0	214-06-211-1000
1200	285	1248	11652	47	66	3	6	528	61100	1710,0	281,0	214-06-066-1200
1200	380	1251	11681	47	114	8	10	288	13000	934,0	293,0	214-06-114-1200
1200	480	1263	11781	47	214	22	20	172	4490	560,0	329,0	214-06-214-1200

**Typ 214 Abmessungen  
Ausführung 1**

**Type 214 Specifications**

**Model 1**

**Druckstufe 10 barg  
Design pressure 10**

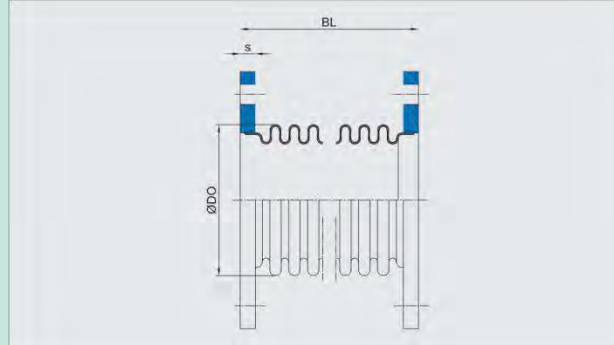

**(PN 10)  
barg (PN 10)**

DN	Länge Length	Balg Bellows			Flansch Flanges	Bewegungsaufnahme Movement			Verstellkraftrate Springrate			Gewicht Weight	Artikel Article
		BL mm	ØDO mm	WF* cm <sup>2</sup>		mm	s mm	axial 2δN mm	lateral 2ΔN mm	angular 2αN °/deg.	axial Cδ N/mm		
25	120	40	9	16	12	9	40	111	33	0,3	2,3	214-10-012-0025	
32	110	50	14	18	15	8	41	86	55	0,4	3,8	214-10-015-0032	
40	160	55	17	18	19	16	46	118	32	0,6	4,4	214-10-019-0040	
50	135	69	28	20	18	9	34	115	96	0,9	5,8	214-10-018-0050	
50	205	69	28	20	31	28	50	112	28	0,9	6,2	214-10-031-0050	
65	145	87	46	20	25	11	37	83	94	1,1	6,6	214-10-025-0065	
65	200	86	45	20	36	25	50	103	46	1,3	7,0	214-10-036-0065	
80	130	114	79	20	23	5	26	83	345	1,9	7,6	214-10-023-0080	
80	160	114	78	20	33	11	37	97	196	2,2	8,0	214-10-033-0080	
80	240	113	77	20	46	29	50	129	73	2,8	8,8	214-10-046-0080	
100	135	144	130	22	30	5	26	56	392	2,1	9,5	214-10-030-0100	
100	175	141	126	22	43	13	39	78	211	2,8	10,1	214-10-043-0100	
100	270	140	122	22	57	32	50	154	107	5,2	11,6	214-10-057-0100	
125	135	170	187	22	30	4	22	66	656	3,4	11,7	214-10-030-0125	
125	175	168	183	22	45	11	33	81	324	4,1	12,1	214-10-045-0125	
125	255	169	181	22	63	27	47	139	173	7,0	14,2	214-10-063-0125	
150	145	203	268	24	28	3	17	139	2300	11,0	15,7	214-10-028-0150	
150	225	206	270	24	61	17	37	102	330	7,6	17,4	214-10-061-0150	

**Typ 214 Abmessungen**  
**Ausführung 1**

**Type 214 Specifications**

150	325	198	256	24	71	33	45	180	179	13,0	19,2	214-10-071-0150
200	160	257	437	24	35	4	17	204	3610	25,0	20,9	214-10-035-0200
200	210	262	446	24	67	13	32	90	626	12,0	22,5	214-10-067-0200
200	275	259	435	24	91	26	44	137	415	17,0	26,5	214-10-091-0200
250	165	313	667	26	35	3	13	228	6200	43,0	26,6	214-10-035-0250
250	210	317	677	26	65	10	25	108	1260	21,0	28,6	214-10-065-0250
250	300	313	659	26	95	24	37	159	590	30,0	35,3	214-10-095-0250
300	165	368	932	26	39	3	12	201	7730	52,0	32,0	214-10-039-0300
300	250	370	933	26	91	16	30	118	1110	31,0	36,7	214-10-091-0300
300	325	373	930	26	115	28	38	177	770	46,0	47,2	214-10-115-0300
350	175	399	1110	30	37	2	11	233	9950	72,0	49,0	214-10-037-0350
350	225	407	1129	30	82	10	24	119	2230	38,0	52,4	214-10-082-0350
350	305	400	1103	30	106	21	32	151	990	47,0	59,0	214-10-106-0350
400	190	459	1459	32	47	3	12	256	14800	104,0	63,0	214-10-047-0400
400	305	459	1461	32	93	15	24	144	1350	59,0	68,1	214-10-093-0400
400	375	458	1443	32	123	27	32	211	1090	85,0	80,1	214-10-123-0400
450	235	508	1818	36	66	6	15	211	7140	107,0	78,4	214-10-066-0450
450	305	515	1838	36	101	14	23	182	2510	93,0	86,8	214-10-101-0450
450	440	515	1822	36	143	34	34	244	1080	124,0	110,0	214-10-143-0450
500	210	562	2236	38	39	2	8	435	41700	270,0	90,5	214-10-039-0500
500	295	568	2254	38	96	10	20	202	4820	126,0	99,3	214-10-096-0500
500	410	569	2249	38	141	26	30	210	1620	131,0	112,0	214-10-141-0500
600	240	660	3147	37	42	2	7	643	51200	562,0	105,0	214-10-042-0600
600	340	669	3183	37	106	11	19	253	5480	224,0	115,0	214-10-106-0600
600	525	678	3208	37	175	37	31	266	1490	237,0	153,0	214-10-175-0600
700	285	772	4280	42	62	3	9	488	30900	580,0	160,0	214-10-062-0700



## Typ 214 Abmessungen Ausführung 1

### Type 214 Specifications

80	130	113	79	20	21	5	24	93	376	2,1	7,7	214-16-021-0080
80	210	112	75	20	40	21	47	170	140	3,6	8,8	214-16-040-0080
100	140	143	128	22	29	5	26	95	569	3,4	9,6	214-16-029-0100
100	190	141	123	22	43	14	39	139	285	4,8	10,6	214-16-043-0100
125	125	170	186	22	19	2	14	175	2390	9,0	11,7	214-16-019-0125
125	165	173	187	22	40	9	29	124	625	6,5	12,6	214-16-040-0125
125	200	172	184	22	50	15	37	146	397	7,5	14,2	214-16-050-0125
150	145	205	269	24	24	3	14	247	3970	19,0	15,8	214-16-024-0150
150	180	208	273	24	40	7	24	131	909	9,9	16,4	214-16-040-0150
150	245	206	265	24	63	19	39	178	444	14,0	19,4	214-16-063-0150
200	155	261	442	26	32	3	15	258	6260	32,0	21,7	214-16-032-0200
200	220	259	438	26	60	12	29	149	927	18,0	23,4	214-16-060-0200
200	315	257	427	26	75	25	36	266	521	32,0	29,7	214-16-075-0200
250	200	309	658	29	34	4	13	257	4080	47,0	29,7	214-16-034-0250
250	235	314	666	29	59	9	23	177	1710	33,0	33,1	214-16-059-0250
250	335	312	652	29	80	24	31	292	782	53,0	41,0	214-16-080-0250
300	175	365	919	32	28	1	9	409	21600	105,0	40,6	214-16-028-0300
300	230	370	928	32	63	8	21	210	3640	54,0	44,9	214-16-063-0300
300	320	369	920	32	89	20	29	244	1150	63,0	55,0	214-16-089-0300
350	190	396	1096	35	34	2	10	380	14500	116,0	59,9	214-16-034-0350
350	230	401	1106	35	60	7	18	242	4570	75,0	63,8	214-16-060-0350
350	325	402	1103	35	90	19	27	249	1440	77,0	74,9	214-16-090-0350
400	225	458	1451	38	45	4	12	405	13600	163,0	80,2	214-16-045-0400
400	290	457	1447	38	71	10	18	268	3310	108,0	82,7	214-16-071-0400
400	320	462	1457	38	97	16	25	227	2170	92,0	89,5	214-16-097-0400
450	235	507	1808	42	42	3	10	501	19500	252,0	102,0	214-16-042-0450

## Typ 214 Abmessungen Ausführung 1

### Type 214 Specifications

450	300	507	1808	42	68	8	16	314	4670	158,0	102,0	214-16-068-0450
450	330	513	1822	42	95	14	22	251	2920	127,0	109,0	214-16-095-0450
500	285	559	2217	46	49	4	10	559	15800	344,0	138,0	214-16-049-0500
500	340	559	2217	46	68	8	14	400	5740	246,0	142,0	214-16-068-0500
500	375	568	2245	46	103	15	22	276	3070	172,0	146,0	214-16-103-0500

\*WF = wirksame Fläche / effective area

Weitere Abmessungen und Werkstoffe auf Anfrage. /  
Other dimensions and materials on request.

**Typ 214 Abmessungen  
Ausführung 1**

**Type 214 Specifications  
Model 1**

**Druckstufe 25 barg (PN 25)  
Design pressure 25 barg (PN 25)**

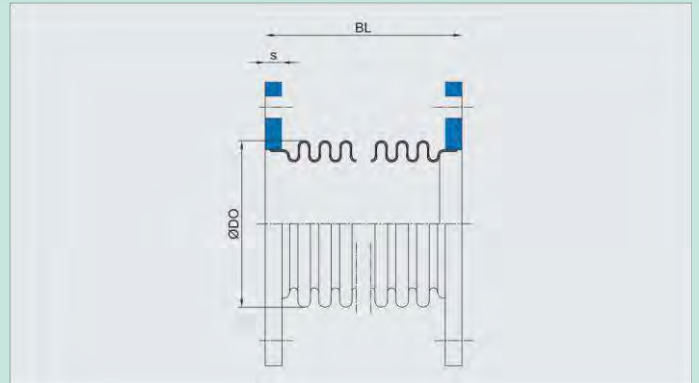

DN	Länge Length	Balg Bellows			Flansch Flanges	Bewegungsaufnahm Movement			Stellkraftrate Springrate			Gewicht Weight	Artikel Article
		BL mm	ØDO	WF* cm <sup>2</sup>		mm	s mm	axial 2ΔN mm	lateral 2ΔN mm	angular 2αN °/deg.	axial Cδ N/mm		
50	125	69	28	20	15	6	28	130	135	1,0	5,2	214-25-015-0050	
50	180	68	27	20	22	17	43	242	84	1,9	5,5	214-25-022-0050	
65	135	85	44	22	16	6	24	147	217	1,8	6,7	214-25-016-0065	
65	230	84	42	22	29	24	45	295	89	3,5	7,7	214-25-029-0065	
80	145	113	78	24	20	5	23	146	481	3,2	8,7	214-25-020-0080	
80	195	112	75	24	31	13	36	208	238	4,4	9,6	214-25-031-0080	
100	140	142	126	26	23	4	20	173	1400	6,0	12,5	214-25-023-0100	
100	195	138	120	26	36	12	33	198	401	6,6	12,9	214-25-036-0100	
125	170	170	184	28	28	5	21	187	1030	9,5	17,3	214-25-028-0125	
125	210	171	181	28	43	12	32	226	612	12,0	19,4	214-25-043-0125	
150	175	206	268	30	25	3	15	310	4190	24,0	21,4	214-25-025-0150	
150	240	203	261	30	47	13	29	257	768	19,0	23,3	214-25-047-0150	

200	170	257	431	32	27	2	13	436	9430	53,0	31,3	214-25-027-0200
200	225	259	435	32	51	9	24	215	1490	26,0	32,2	214-25-051-0200
200	290	257	427	32	60	17	29	319	892	38,0	36,9	214-25-060-0200
250	180	309	650	35	24	2	9	645	18800	117,0	42,7	214-25-024-0250
250	230	311	655	35	46	7	18	316	3230	58,0	46,6	214-25-046-0250
250	305	314	657	35	63	14	24	329	1450	60,0	50,7	214-25-063-0250
300	200	360	901	38	30	2	10	590	16400	148,0	57,9	214-25-030-0300
300	255	360	901	38	48	7	16	369	3850	93,0	59,9	214-25-048-0300
300	280	370	922	38	65	11	21	305	2500	79,0	64,9	214-25-065-0300
350	210	391	1076	42	28	2	8	691	21700	207,0	87,9	214-25-028-0350
350	265	391	1076	42	45	6	13	432	5120	129,0	87,9	214-25-045-0350
350	290	401	1100	42	62	9	18	353	3320	108,0	92,8	214-25-062-0350
400	235	450	1416	48	28	2	7	1020	39700	401,0	120,0	214-25-028-0400
400	275	452	1423	48	46	5	12	599	11500	237,0	123,0	214-25-046-0400
400	375	459	1441	48	82	15	21	399	2540	160,0	140,0	214-25-082-0400

\*WF = wirksame Fläche / effective area

Weitere Abmessungen und Werkstoffe auf Anfrage. /  
Other dimensions and materials on request.

## Lateralkompensator Anschweißenden und Zugstangen Typ 220/Typ 221 (mit Innenleitrohr)

Der Typ 220 ist ein mehrlagiger Lateralkompensator mit Anschweißenden, Die Zugstangenverspannung ist auf die Anschlüsse aufgeschweißt.

Er ist speziell konzipiert für den Betrieb in Anlagen mit Betriebsdrücken bis max. 63 barg.

Dieser Kompensator lässt ausschließlich laterale Bewegungen zu.

### Beschreibung

Neben den aufgeführten Standardbaulängen kann die Baulänge speziell auf Ihre Bedürfnisse angepasst gefertigt werden. Dieser Kompensator kann auch in anderen Werkstoffen (siehe Seite 179) gefertigt werden.

## Lateral expansion joint with weld ends and tie rods Type 220 Type 221 (with internal sleeve)



### Ausführung

Zur Realisierung größerer Kompensatorenbaulängen ist die Variante mit einem eingeschweißten Zwischenrohr (Ausführung 2) erhältlich. Bei Vakuumbetrieb auch zuzüglich innerer Zugverspannung.

### Vorteile

- Einfache Lösung für die Kompensation von Temperaturschwankungen
- Keine Strömungsumlenkung
- Kompakte und platzsparende Lösung
- Relativ geringe Kosten



## Lateralkompensator Anschweißenden und Zugstangen

**Typ 220**

**Typ 221 (mit Innenleitrohr)**

Type 220 is a multi-layer lateral expansion joint with weld ends. This expansion joint has tie rods.

It is designed specifically for operation in installations with operating pressures up to 63 barg.

This expansion joint only allows lateral movements.

### Description

In addition to the given standard lengths, other lengths are available to meet specific requirements. This expansion joint can also be produced in other materials (see pages 179).

### Versions

For longer expansion joint lengths, a version with a welded intermediate pipe is available (version 2). For vacuum operation also additional lock

## Lateral expansion joint with weld ends and tie rods

**Typ 220**

**Typ 221 (with internal sleeve)**

nuts are available.

### Advantages

- Simple solution for temperature fluctuation compensation
- No flow deflection
- Compact and space-saving solution
- Relatively low costs

<b>Einsatzbeispiele</b>	Dampfanlagen, Wasser, Entwässerung etc.
<b>Standardmäßiger Aufbau</b>	Mehrlagiger Wellrohrbalg aus 1.4541 mit Anschweißenden und Verspannung aus C-Stahl. Ab einer Anschweißendendicke von 3,5 mm ist das Anschweißende montagefertig gefast.
<b>Zulässige Betriebsdaten (Standard)</b>	16 barg / 120 °C gem. EJMA Höhere Drücke auf Anfrage.
<b>Zubehör</b>	Innenleitrohr
<b>Hinweis</b>	Bei Verwendung von Leitrohren vermindert sich der Balgquerschnitt. Bitte beachten Sie bei Ihrer Planung die Medienverträglichkeit der zu verwendenden Kompensatorenmaterialien.

<b>Application examples</b>	Steam plants, water, drainage, etc.
<b>Standard design</b>	Multi-layer corrugated tube bellows of 1.4541 with weld ends and tie rods of carbon steel. From a weld end thickness of 3.5 mm, these parts are bevelled ready for installation.
<b>Permissible operating data</b>	16 barg / 120 °C acc. to EJMA Higher pressures on request.
<b>Accessories</b>	Internal sleeve
<b>Note</b>	Using internal sleeves will reduce the bellows cross-section. To be noted is that the media compatibility of the expansion joint material to be used should be taken into account in the planning phase.

## Ausführungsvarianten / Versions

**Ausführung 1 / Model 1**



**Ausführung 2 / Model 2**



**Typ 220 Abmessungen**  
**Ausführung 1**

**Type 220 Specifications**

**Druckstufe 6 barg (PN 6) Design pressure 6 barg (PN 6)**

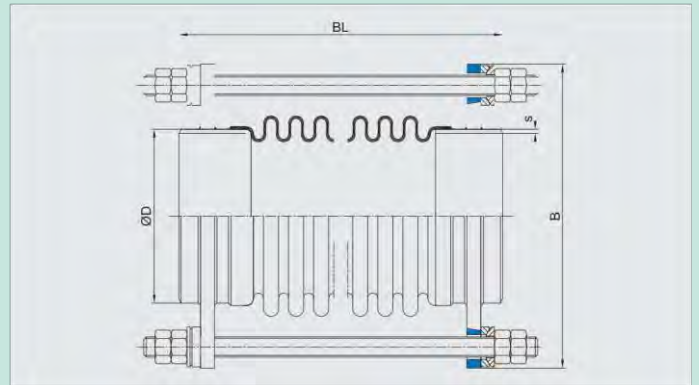

DN	Länge Length		Größte Breite Biggest width		Anschweißenden Weld ends		Bewegungsaufnahme Movement lateral	Verstellmomentrate Friction rate			Gewicht Weight kg	Artikel Article
	BL mm	B mm	ØD s mm	mm	2λN mm	CA N/mm		Cp N/mm barg	Cr N/barg			
50	355	145	60,3	2,9	16	46	0	5,0	3,4	220-06-016-0050		
50	455	145	60,3	2,9	43	11	0	3,7	4,0	220-06-043-0050		
65	335	155	76,1	2,9	12	82	0	8,9	3,1	220-06-012-0065		
65	400	155	76,1	2,9	32	29	0	7,1	3,8	220-06-032-0065		
80	305	185	88,9	3,2	6	295	0	18,0	4,8	220-06-006-0080		
80	350	185	88,9	3,2	15	62	0	15,0	5,0	220-06-015-0080		
80	415	185	88,9	3,2	33	38	0	12,0	6,1	220-06-033-0080		
100	315	215	114,3	3,6	6	307	0	28,0	6,2	220-06-006-0100		
100	355	215	114,3	3,6	16	129	0	23,0	6,5	220-06-016-0100		
100	445	215	114,3	3,6	39	59	0	18,0	9,0	220-06-039-0100		
125	315	245	139,7	4,0	5	514	0	39,0	8,5	220-06-005-0125		
125	365	245	139,7	4,0	16	144	0	32,0	9,5	220-06-016-0125		
125	470	245	139,7	4,0	40	75	0	24,0	12,6	220-06-040-0125		
150	335	290	168,3	4,5	6	597	0	65,0	10,5	220-06-006-0150		
150	420	290	168,3	4,5	21	213	0	49,0	13,0	220-06-021-0150		
150	525	290	168,3	4,5	50	91	0	37,0	17,5	220-06-050-0150		
200	350	345	219,1	6,3	7	535	0	100,0	16,8	220-06-007-0200		
200	435	345	219,1	6,3	22	218	0	77,0	19,8	220-06-022-0200		
200	485	345	219,1	6,3	39	191	0	67,0	24,0	220-06-039-0200		
250	370	405	273,0	6,3	5	1190	0	140,0	27,0	220-06-005-0250		
250	455	405	273,0	6,3	19	399	0	111,0	30,2	220-06-019-0250		
250	545	405	273,0	6,3	33	210	0	89,0	36,4	220-06-033-0250		
300	410	460	323,9	7,1	5	2020	0	174,0	55,8	220-06-005-0300		
300	455	460	323,9	7,1	12	636	0	154,0	56,7	220-06-012-0300		
300	515	460	323,9	7,1	24	461	0	135,0	62,0	220-06-024-0300		

Weitere Abmessungen und Werkstoffe auf Anfrage. /  
Other dimensions and materials on request.

**Typ 220 Abmessungen  
Ausführung 1**

**Type 220 Specifications  
Model 1**

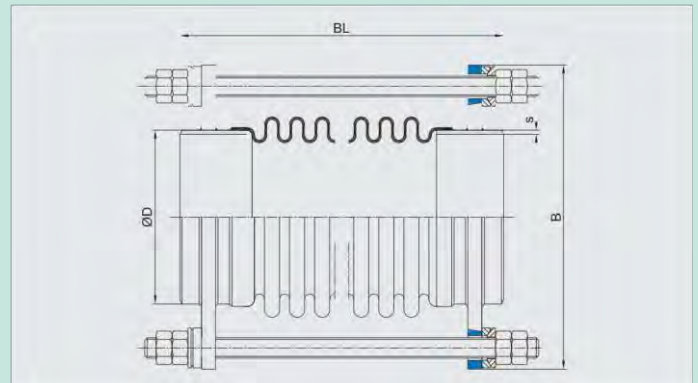

350	400	500	355,6	6,3	5	2780	0	213,0	52,0	220-06-005-0350
350	445	500	355,6	6,3	11	713	0	189,0	54,9	220-06-011-0350
350	540	500	355,6	6,3	25	412	0	152,0	63,7	220-06-025-0350
400	460	575	406,4	6,3	7	1730	0	284,0	69,7	220-06-007-0400
400	525	575	406,4	6,3	17	590	0	247,0	75,8	220-06-017-0400
400	665	575	406,4	6,3	38	369	0	189,0	91,4	220-06-038-0400
450	455	630	457,0	6,3	5	4730	0	364,0	91,6	220-06-005-0450
450	510	630	457,0	6,3	12	1200	0	323,0	94,7	220-06-012-0450
450	630	630	457,0	6,3	31	537	0	254,0	109,0	220-06-031-0450
500	465	685	508,0	6,3	5	4760	0	439,0	104,0	220-06-005-0500
500	560	685	508,0	6,3	16	900	0	358,0	108,0	220-06-016-0500
500	660	685	508,0	6,3	33	584	0	298,0	129,0	220-06-033-0500

**Model 1**

**Druckstufe 10 barg (PN 10)**  
Design pressure 10 barg (PN 10)

Weitere Abmessungen und Werkstoffe auf Anfrage./  
Other dimensions and materials on request.

## Typ 220 Abmessungen Ausführung 1

### Type 220 Specifications

DN	Länge Length	Größte Breite Biggest width	Anschweißenden Weld ends		Bewegungsaufnahme Movement lateral	Verstellmomentrate Friction rate			Gewicht Weight	Artikel Article	
	BL mm	B mm	ØD	s mm	mm	2AN mm	Cλ N/mm	Cp N/mm barg	Cr N/barg	kg	
50	335	145	60,3		2,9	10	85	0	5,5	3,4	220-10-010-0050
50	405	145	60,3		2,9	25	25	0	4,3	4,0	220-10-025-0050
65	325	155	76,1		2,9	9	132	0	9,1	3,2	220-10-009-0065
65	390	155	76,1		2,9	21	40	0	7,2	3,7	220-10-021-0065
80	310	185	88,9		3,2	6	277	0	17,0	4,8	220-10-006-0080
80	385	185	88,9		3,2	26	117	0	13,0	6,1	220-10-026-0080
80	415	185	88,9		3,2	26	62	0	12,0	6,1	220-10-026-0080
100	320	215	114,3		3,6	6	472	0	26,0	6,5	220-10-006-0100
100	355	215	114,3		3,6	12	168	0	23,0	6,8	220-10-012-0100
100	445	215	114,3		3,6	30	95	0	17,0	9,0	220-10-030-0100
125	315	245	139,7		4,0	4	557	0	39,0	8,2	220-10-004-0125
125	356	245	139,7		4,0	11	255	0	33,0	9,1	220-10-011-0125
125	430	245	139,7		4,0	25	148	0	26,0	11,9	220-10-025-0125
150	330	295	168,3		4,5	3	1920	0	65,0	13,2	220-10-003-0150
150	415	295	168,3		4,5	15	245	0	50,0	14,7	220-10-015-0150
150	510	295	168,3		4,5	31	153	0	38,0	16,5	220-10-031-0150
200	380	365	219,1		6,3	4	2590	0	106,0	25,7	220-10-004-0200
200	425	365	219,1		6,3	12	483	0	96,0	26,3	220-10-012-0200
200	490	365	219,1		6,3	24	315	0	80,0	31,5	220-10-024-0200
250	360	405	273,0		6,3	3	4440	0	146,0	27,7	220-10-003-0250
250	405	405	273,0		6,3	10	885	0	129,0	29,2	220-10-010-0250
250	490	405	273,0		6,3	23	456	0	101,0	37,1	220-10-023-0250
300	400	460	323,9		7,1	3	5560	0	180,0	57,0	220-10-003-0300
300	485	460	323,9		7,1	14	760	0	144,0	60,5	220-10-014-0300
300	555	460	323,9		7,1	26	567	0	124,0	70,1	220-10-026-0300
350	400	505	355,6		6,3	3	7660	0	214,0	64,5	220-10-003-0350
350	450	505	355,6		6,3	10	1530	0	190,0	69,7	220-10-010-0350
350	525	505	355,6		6,3	19	753	0	156,0	75,3	220-10-019-0350
400	430	575	406,4		6,3	3	11000	0	308,0	93,3	220-10-003-0400
400	550	575	406,4		6,3	15	1010	0	235,0	99,3	220-10-015-0400
400	615	575	406,4		6,3	27	826	0	206,0	112,0	220-10-027-0400
450	470	625	457,0		8,8	6	5160	0	347,0	117,0	220-10-006-0450
450	535	625	457,0		8,8	14	1880	0	305,0	126,0	220-10-014-0450
450	665	625	457,0		8,8	32	853	0	239,0	150,0	220-10-032-0450
500	460	695	508,0		8,8	2	29300	0	501,0	141,0	220-10-002-0500
500	540	695	508,0		8,8	10	3380	0	426,0	151,0	220-10-010-0500
500	655	695	508,0		8,8	25	1200	0	347,0	166,0	220-10-025-0500

**Typ 220 Abmessungen  
Ausführung 1**

**Type 220 Specifications  
Model 1**

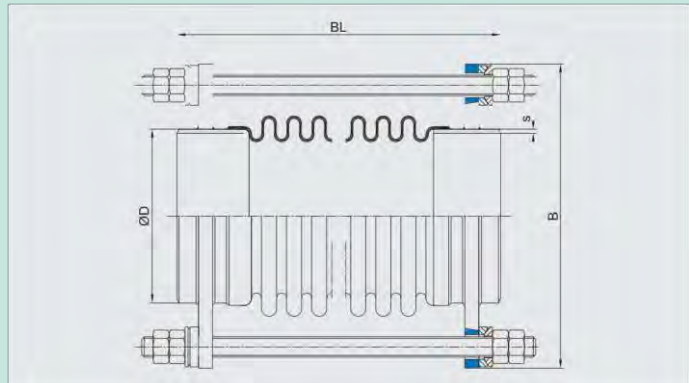

**Druckstufe 16 barg (PN 16)  
Design pressure 16 barg (PN 16)**

DN	Länge Length	Größte Breite Biggest width		Anschweißenden Weld ends		Bewegungsaufnahme Movement lateral	Verstellmomentrate Friction rate			Gewicht Weight kg	Artikel Article
	BL mm	B mm	ØD	s mm	mm		CA N/mm	Cp N/mm barg	Cr N/barg		
50	335	145	60,3	2,9	9	85	0	5,5	3,4	220-16-009-0050	
50	415	145	60,3	2,9	25	38	0	4,0	4,2	220-16-025-0050	
65	325	155	76,1	2,9	8	132	0	9,1	3,2	220-16-008-0065	
65	400	155	76,1	2,9	24	62	0	7,0	4,1	220-16-024-0065	
80	310	185	88,9	3,2	5	277	0	17,0	4,8	220-16-005-0080	
80	385	185	88,9	3,2	19	117	0	13,0	6,1	220-16-019-0080	
100	320	215	114,3	3,6	6	472	0	26,0	6,5	220-16-006-0100	
100	365	215	114,3	3,6	13	249	0	22,0	7,6	220-16-013-0100	
125	305	245	139,7	4,0	2	1980	0	40,0	8,6	220-16-002-0125	
125	345	245	139,7	4,0	9	493	0	35,0	9,3	220-16-009-0125	
125	380	245	139,7	4,0	14	306	0	31,0	11,2	220-16-014-0125	
150	335	295	168,3	4,5	3	2990	0	64,0	13,9	220-16-003-0150	
150	365	295	168,3	4,5	7	750	0	59,0	13,9	220-16-007-0150	
150	425	295	168,3	4,5	17	374	0	48,0	17,3	220-16-017-0150	
200	365	365	219,1	6,3	3	5180	0	112,0	26,5	220-16-003-0200	
200	430	365	219,1	6,3	11	730	0	93,0	28,4	220-16-011-0200	
200	520	365	219,1	6,3	24	448	0	73,0	35,3	220-16-024-0200	
250	405	415	273,0	6,3	4	3620	0	149,0	57,3	220-16-004-0250	
250	440	415	273,0	6,3	10	1320	0	137,0	60,4	220-16-010-0250	
250	550	415	273,0	6,3	22	629	0	105,0	69,1	220-16-022-0250	

**Typ 220 Abmessungen  
Ausführung 1**

**Type 220 Specifications**

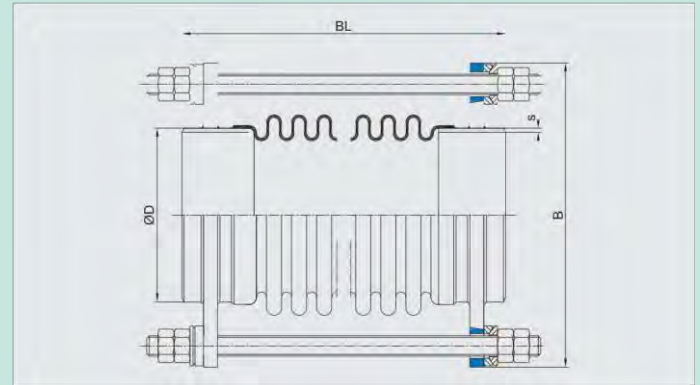

300	415	470	323,9	7,1	2	16900	0	202,0	70,8	<b>220-16-002-0300</b>
300	470	470	323,9	7,1	8	2560	0	177,0	75,4	<b>220-16-008-0300</b>
300	570	470	323,9	7,1	18	876	0	142,0	81,3	<b>220-16-018-0300</b>
350	435	520	355,6	8,0	3	11100	0	228,0	85,9	<b>220-16-003-0350</b>
350	470	520	355,6	8,0	7	3510	0	211,0	92,5	<b>220-16-007-0350</b>
350	565	520	355,6	8,0	17	1140	0	172,0	105,0	<b>220-16-017-0350</b>
400	505	585	406,4	8,8	4	10200	0	295,0	142,0	<b>220-16-004-0400</b>
400	570	585	406,4	8,8	10	2570	0	258,0	145,0	<b>220-16-010-0400</b>
400	595	585	406,4	8,8	15	1670	0	249,0	153,0	<b>220-16-015-0400</b>
450	505	645	457,0	8,8	3	15600	0	367,0	162,0	<b>220-16-003-0450</b>
450	570	645	457,0	8,8	9	3740	0	323,0	166,0	<b>220-16-009-0450</b>
450	595	645	457,0	8,8	14	2310	0	311,0	174,0	<b>220-16-014-0450</b>

Weitere Abmessungen und Werkstoffe auf Anfrage,  
/ Other dimensions and materials on request.

**Model 1**

**Druckstufe 25 barg (PN 25)**

## Typ 220 Abmessungen Ausführung 1

## Type 220 Specifications Model 1

### Design pressure 25 barg (PN 25)

DN	Länge Length	Größte Breite Biggest width	Anschweißenden Weld ends		Bewegungsaufnahme Movement lateral	Verstellmomentrate Friction rate			Gewicht Weight	Artikel Article	
	BL mm	B mm	ØD	s mm	mm	2λN mm	Cλ N/mm	Cp N/mm barg	Cr N/barg	kg	
50	325	145	60,3		4,0	6	121	0	5,6	3,7	220-25-006-0050
50	380	145	60,3		4,0	16	77	0	4,5	4,2	220-25-016-0050
65	325	155	76,1		4,0	6	176	0	8,7	3,7	220-25-006-0065
65	415	155	76,1		4,0	21	82	0	6,3	4,9	220-25-021-0065
80	310	185	88,9		4,0	5	442	0	17,0	5,4	220-25-005-0080
80	360	185	88,9		4,0	12	208	0	14,0	6,3	220-25-012-0080
100	330	235	114,3		4,0	4	1140	0	31,0	9,9	220-25-004-0100
100	385	235	114,3		4,0	10	339	0	25,0	10,4	220-25-010-0100
125	365	260	139,7		4,0	5	892	0	40,0	22,5	220-25-005-0125
125	405	260	139,7		4,0	12	497	0	35,0	24,9	220-25-012-0125
150	375	310	168,3		4,5	3	3670	0	66,0	36,6	220-25-003-0150
150	450	310	168,3		4,5	12	651	0	53,0	39,6	220-25-012-0150
200	380	360	219,1		6,3	3	7320	0	105,0	47,9	220-25-003-0200
200	430	360	219,1		6,3	9	1250	0	92,0	50,5	220-25-009-0200
250	380	415	273,0		7,1	2	16700	0	158,0	60,1	220-25-002-0250
250	435	415	273,0		7,1	7	2540	0	137,0	63,3	220-25-007-0250
250	495	415	273,0		7,1	13	1200	0	119,0	68,2	220-25-013-0250
300	490	485	323,9		8,0	3	12700	0	189,0	105,0	220-25-003-0300
300	540	485	323,9		8,0	7	3200	0	171,0	108,0	220-25-007-0300
300	565	485	323,9		8,0	11	1970	0	166,0	113,0	220-25-011-0300
350	490	530	355,6		8,0	2	17700	0	226,0	120,0	220-25-002-0350
350	540	530	355,6		8,0	6	4520	0	204,0	123,0	220-25-006-0350
350	565	530	355,6		8,0	10	2750	0	198,0	129,0	220-25-010-0350

Weitere Abmessungen und Werkstoffe auf Anfrage.  
/ Other dimensions and materials on request.



**Typ 220 Abmessungen  
Ausführung 1**

**Type 220 Specifications**

**Druckstufe 40 barg (PN 40)  
Design pressure 40 barg (PN 40)**

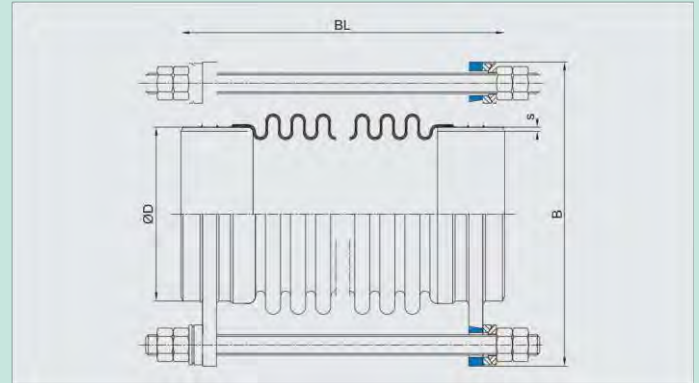

DN	Länge Length	Größte Breite Biggest width	Anschweißenden Weld ends		Bewegungsaufnahme Movement lateral	Verstellmomentrate Friction rate			Gewicht Weight	Artikel Article
			ØD	s		mm	mm	CA N/mm		
50	320	145	60,3	4,0	6	274	0	5,7	3,7	220-40-006-0050
50	360	145	60,3	4,0	10	141	0	5,2	4,0	220-40-010-0050
65	355	175	76,1	4,0	6	294	0	9,7	6,4	220-40-006-0065
65	405	175	76,1	4,0	13	194	0	8,9	7,2	220-40-013-0065
80	335	210	88,9	4,0	5	699	0	18,0	13,9	220-40-005-0080
80	370	210	88,9	4,0	10	450	0	18,0	15,0	220-40-010-0080
100	355	235	114,3	4,0	5	863	0	29,0	9,9	220-40-005-0100
100	395	235	114,3	4,0	10	610	0	27,0	11,2	220-40-010-0100
125	370	260	139,7	4,0	5	1410	0	38,0	22,2	220-40-005-0125
125	405	260	139,7	4,0	9	793	0	36,0	23,6	220-40-009-0125
150	415	310	168,3	4,5	6	1840	0	57,0	37,3	220-40-006-0150
150	480	310	168,3	4,5	12	824	0	52,0	40,1	220-40-012-0150
200	490	375	219,1	6,3	7	2720	0	89,0	69,0	220-40-007-0200
200	525	375	219,1	6,3	10	1450	0	88,0	70,9	220-40-010-0200

**Typ 220 Abmessungen**  
**Ausführung 1**

**Type 220 Specifications**  
**Model 1**

250	490	435	273,0	7,1	6	4610	0	136,0	88,3	<b>220-40-006-0250</b>
250	555	435	273,0	7,1	12	1930	0	127,0	94,7	<b>220-40-012-0250</b>

Weitere Abmessungen und Werkstoffe auf Anfrage.  
/ Other dimensions and materials on request.

**Typ 220 Abmessungen  
Ausführung 1**

**Type 220 Specifications**

**Model 1**

**Druckstufe 63 barg (PN 63)  
Design pressure 63 barg (PN 63)**

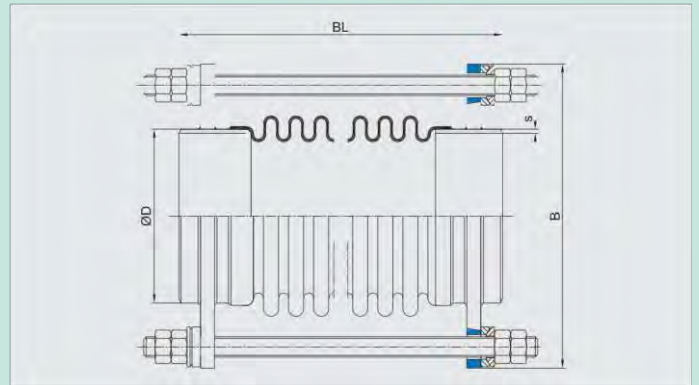

DN	Länge Length		Größte Breite Biggest width		Anschweißenden Weld ends		Bewegungsaufnahme Movement lateral	Verstellmomentrate Friction rate			Gewicht Weight kg	Artikel Article
	BL mm	B mm	ØD mm	s mm	mm	2λN mm		Cλ N/mm	Cp N/mm barg	Cr N/barg		
50	295	145	60,3	4,0	1	2310	0	6,2	3,8	220-63-001-0050		
50	335	145	60,3	4,0	5	510	0	6,1	4,0	220-63-005-0050		
65	325	175	76,1	4,0	2	2530	0	12,0	6,4	220-63-002-0065		
65	365	175	76,1	4,0	5	661	0	10,0	6,6	220-63-005-0065		
80	315	210	88,9	4,0	2	3340	0	20,0	13,7	220-63-002-0080		
80	355	210	88,9	4,0	6	735	0	19,0	14,2	220-63-006-0080		
100	330	230	114,3	5,0	1	9840	0	29,0	19,0	220-63-001-0100		
100	380	230	114,3	5,0	5	1350	0	27,0	19,3	220-63-005-0100		
125	365	275	139,7	6,3	1	12200	0	45,0	32,5	220-63-001-0125		
125	435	275	139,7	6,3	6	1260	0	40,0	33,6	220-63-006-0125		
150	425	320	168,3	6,3	2	16500	0	61,0	49,1	220-63-002-0150		
150	480	320	168,3	6,3	7	2170	0	59,0	51,5	220-63-007-0150		
200	440	380	219,1	8,0	1	45800	0	99,0	86,1	220-63-001-0200		
200	520	380	219,1	8,0	6	5000	0	89,0	90,2	220-63-006-0200		

**Typ 220 Abmessungen  
Ausführung 2**

**Type 220 Specifications**

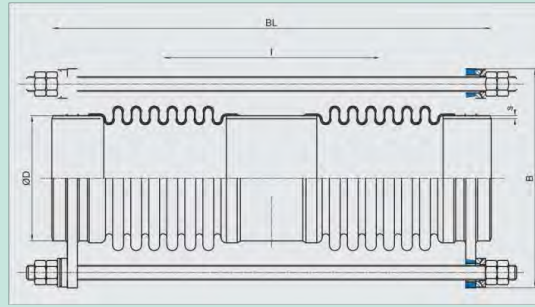

**Model 2**

**Druckstufe 6 barg (PN 6)  
Design pressure 6 barg (PN 6)**

Weitere Abmessungen und Werkstoffe auf Anfrage.  
/ Other dimensions and materials on request.

DN	Länge	Größte Breite Biggest width	Balg Bellows	Anschweißenden Weld ends		Bewegungsaufnahme Movement lateral	Verstellmomentrate Friction rate			Gewicht Weight	Artikel Article
	BL			B	I*		ØD	s	2ΔN		
	mm	mm	mm	mm	mm	mm	N/mm	N/mm barg	N/barg	kg	
50	495	145	167	60,3	2,9	62	3,9	0	3,4	4,4	220-06-062-0050
50	575	145	247	60,3	2,9	99	1,9	0	2,8	4,7	220-06-099-0050
50	675	145	347	60,3	2,9	147	1,0	0	2,4	5,3	220-06-147-0050
50	775	145	447	60,3	2,9	196	0,6	0	2,1	5,9	220-06-196-0050
65	495	155	173	76,1	2,9	61	6,5	0	5,3	4,4	220-06-061-0065
65	585	155	263	76,1	2,9	100	2,9	0	4,5	4,9	220-06-100-0065
65	695	155	373	76,1	2,9	150	1,5	0	3,6	5,7	220-06-150-0065
65	805	155	483	76,1	2,9	201	0,9	0	3,1	6,5	220-06-201-0065
80	460	185	150	88,9	3,2	59	15,0	0	11,0	6,4	220-06-059-0080
80	550	185	240	88,9	3,2	103	6,1	0	8,4	7,2	220-06-103-0080
80	650	185	340	88,9	3,2	154	3,1	0	6,9	8,1	220-06-154-0080
80	740	185	430	88,9	3,2	201	2,0	0	6,0	8,9	220-06-201-0080
100	455	215	142	114,3	3,6	52	32,0	0	17,0	9,1	220-06-052-0100
100	565	215	252	114,3	3,6	103	11,0	0	13,0	10,4	220-06-103-0100
100	665	215	352	114,3	3,6	152	5,5	0	11,0	11,5	220-06-152-0100
100	765	215	452	114,3	3,6	201	3,4	0	9,2	12,7	220-06-201-0100
125	505	245	198	139,7	4,0	51	26,0	0	22,0	11,9	220-06-051-0125
125	665	245	358	139,7	4,0	101	8,0	0	16,0	14,2	220-06-101-0125
125	825	245	518	139,7	4,0	152	3,9	0	13,0	16,6	220-06-152-0125
125	1005	245	698	139,7	4,0	201	2,2	0	11,0	19,4	220-06-201-0125
150	495	290	172	168,3	4,5	52	38,0	0	41,0	14,9	220-06-052-0150
150	625	290	302	168,3	4,5	100	13,0	0	32,0	17,7	220-06-100-0150
150	755	290	432	168,3	4,5	150	6,3	0	26,0	20,4	220-06-150-0150
150	895	290	572	168,3	4,5	201	3,6	0	22,0	23,4	220-06-201-0150
200	530	345	190	219,1	6,3	50	74,0	0	61,0	25,4	220-06-050-0200
200	690	345	350	219,1	6,3	102	23,0	0	46,0	31,1	220-06-102-0200
200	830	345	490	219,1	6,3	150	12,0	0	38,0	36,1	220-06-150-0200
200	980	345	640	219,1	6,3	202	6,9	0	32,0	41,7	220-06-202-0200
250	590	405	230	273,0	6,3	52	88,0	0	83,0	37,4	220-06-052-0250
250	770	405	410	273,0	6,3	102	29,0	0	62,0	45,3	220-06-102-0250
250	940	405	580	273,0	6,3	151	15,0	0	50,0	52,9	220-06-151-0250
250	1110	405	750	273,0	6,3	200	8,6	0	42,0	60,6	220-06-200-0250
300	625	460	228	323,9	7,1	50	111,0	0	109,0	71,1	220-06-050-0300
300	815	460	418	323,9	7,1	101	34,0	0	82,0	82,5	220-06-101-0300
300	995	460	598	323,9	7,1	151	17,0	0	66,0	93,4	220-06-151-0300
300	1185	460	788	323,9	7,1	200	9,6	0	55,0	105,0	220-06-200-0300
350	645	500	257	355,6	6,3	51	121,0	0	125,0	70,3	220-06-051-0350
350	855	500	467	355,6	6,3	101	38,0	0	92,0	82,9	220-06-101-0350
350	1055	500	667	355,6	6,3	150	19,0	0	74,0	94,6	220-06-150-0350
350	1285	500	897	355,6	6,3	201	11,0	0	60,0	109,0	220-06-201-0350
400	660	575	250	406,4	6,3	52	185,0	0	193,0	92,7	220-06-052-0400
400	850	575	440	406,4	6,3	100	61,0	0	147,0	106,0	220-06-100-0400

## Typ 220 Abmessungen Ausführung 2

### Type 220 Specifications

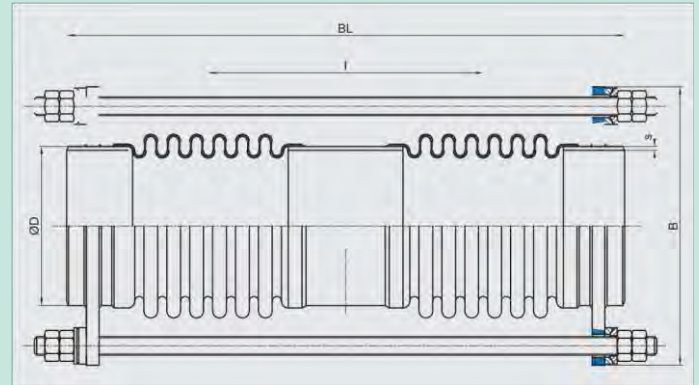

400	1055	575	643	406,4	6,3	152	29,0	0	118,0	120,0	220-06-152-0400
400	1255	575	843	406,4	6,3	202	17,0	0	98,0	134,0	220-06-202-0400
450	700	630	240	457,0	6,3	51	195,0	0	225,0	118,0	220-06-051-0450
450	890	630	430	457,0	6,3	102	65,0	0	175,0	133,0	220-06-102-0450
450	1070	630	610	457,0	6,3	152	33,0	0	144,0	146,0	220-06-152-0450
450	1240	630	780	457,0	6,3	201	20,0	0	124,0	159,0	220-06-201-0450
500	755	685	338	508,0	6,3	50	268,0	0	256,0	139,0	220-06-050-0500
500	1035	685	618	508,0	6,3	100	81,0	0	184,0	164,0	220-06-100-0500
500	1315	685	898	508,0	6,3	150	39,0	0	143,0	188,0	220-06-150-0500
500	1595	685	1178	508,0	6,3	200	23,0	0	117,0	213,0	220-06-200-0500

\*I = Mittenabstand / center distance

Weitere Abmessungen und Werkstoffe auf Anfrage. /  
Other dimensions and materials on request.

## Model 2

### Druckstufe 10 barg (PN 10)

#### Design pressure 10 barg (PN 10)

DN	Länge Length	Größte Breite Biggest width	Balg Bellow	Anschweißenden Weld ends		Bewegungsaufnahme Movement lateral	Verstellmomentrate Friction rate			Gewicht Weight	Artikel Article
				ØD mm	s mm		C <sub>λ</sub> N/mm	C <sub>p</sub> N/mm barg	C <sub>r</sub> N/barg		
50	485	145	162	60,3	2,9	63	7,6	0	3,5	4,2	220-10-063-0050
50	565	145	242	60,3	2,9	101	3,6	0	2,9	4,7	220-10-101-0050
50	665	145	342	60,3	2,9	151	1,8	0	2,4	5,3	220-10-151-0050
50	755	145	432	60,3	2,9	197	1,2	0	2,1	5,9	220-10-197-0050
65	505	155	178	76,1	2,9	57	9,7	0	5,1	4,4	220-10-057-0065
65	615	155	288	76,1	2,9	101	3,9	0	4,1	5,2	220-10-101-0065
65	735	155	408	76,1	2,9	151	2,0	0	3,4	6,1	220-10-151-0065
65	855	155	528	76,1	2,9	203	1,2	0	2,9	6,9	220-10-203-0065
80	470	185	155	88,9	3,2	55	25,0	0	9,6	6,6	220-10-055-0080
80	570	185	255	88,9	3,2	100	9,6	0	7,7	7,5	220-10-100-0080
80	680	185	365	88,9	3,2	152	4,8	0	6,3	8,4	220-10-152-0080
80	780	185	465	88,9	3,2	200	3,0	0	5,5	9,3	220-10-200-0080
100	485	215	172	114,3	3,6	51	23,0	0	16,0	9,4	220-10-051-0100
100	615	215	302	114,3	3,6	99	7,4	0	12,0	11,0	220-10-099-0100

## Typ 220 Abmessungen Ausführung 2

### Type 220 Specifications

100	745	215	432	114,3	3,6	149	3,7	0	9,5	12,5	220-10-149-0100
100	865	215	552	114,3	3,6	195	2,3	0	8,1	13,9	220-10-195-0100
125	525	245	218	139,7	4,0	51	22,0	0	21,0	12,2	220-10-051-0125
125	695	245	388	139,7	4,0	99	6,9	0	16,0	14,6	220-10-099-0125
125	875	245	568	139,7	4,0	151	3,2	0	12,0	17,4	220-10-151-0125
125	1075	245	768	139,7	4,0	201	1,8	0	9,5	20,5	220-10-201-0125
150	535	295	202	168,3	4,5	51	50,0	0	38,0	18,9	220-10-051-0150
150	695	295	362	168,3	4,5	101	16,0	0	28,0	22,2	220-10-101-0150
150	855	295	522	168,3	4,5	152	7,7	0	23,0	25,7	220-10-152-0150
150	1035	295	702	168,3	4,5	201	4,3	0	19,0	29,6	220-10-201-0150
200	570	365	205	219,1	6,3	52	84,0	0	69,0	35,8	220-10-052-0200
200	730	365	365	219,1	6,3	102	27,0	0	53,0	41,9	220-10-102-0200
200	880	365	515	219,1	6,3	150	14,0	0	43,0	47,4	220-10-150-0200
200	1060	365	695	219,1	6,3	201	7,5	0	36,0	54,4	220-10-201-0200
250	620	405	260	273,0	6,3	51	70,0	0	79,0	38,6	220-10-051-0250
250	820	405	460	273,0	6,3	99	23,0	0	58,0	47,5	220-10-099-0250
250	1020	405	660	273,0	6,3	148	12,0	0	46,0	56,4	220-10-148-0250
250	1220	405	860	273,0	6,3	197	6,6	0	38,0	65,5	220-10-197-0250
300	680	460	295	323,9	7,1	50	135,0	0	98,0	77,4	220-10-050-0300
300	930	460	545	323,9	7,1	101	40,0	0	70,0	92,5	220-10-101-0300
300	1200	460	815	323,9	7,1	151	18,0	0	54,0	109,0	220-10-151-0300
300	1480	460	1095	323,9	7,1	200	10,0	0	43,0	126,0	220-10-200-0300
350	685	505	287	355,6	6,3	51	97,0	0	117,0	82,8	220-10-051-0350
350	915	505	517	355,6	6,3	100	31,0	0	86,0	96,9	220-10-100-0350
350	1145	505	747	355,6	6,3	150	15,0	0	68,0	111,0	220-10-150-0350
350	1405	505	1007	355,6	6,3	200	8,1	0	55,0	127,0	220-10-200-0350
400	690	575	260	406,4	6,3	51	171,0	0	184,0	115,0	220-10-051-0400
400	900	575	470	406,4	6,3	101	54,0	0	139,0	130,0	220-10-101-0400
400	1110	575	680	406,4	6,3	150	26,0	0	112,0	144,0	220-10-150-0400
400	1370	575	940	406,4	6,3	201	14,0	0	90,0	162,0	220-10-201-0400
450	750	625	295	457,0	8,8	49	317,0	0	208,0	155,0	220-10-049-0450
450	1000	625	545	457,0	8,8	101	96,0	0	154,0	182,0	220-10-101-0450
450	1230	625	775	457,0	8,8	151	48,0	0	124,0	206,0	220-10-151-0450
450	1460	625	1005	457,0	8,8	200	29,0	0	104,0	231,0	220-10-200-0450
500	815	695	358	508,0	8,8	51	239,0	0	274,0	187,0	220-10-051-0500
500	1115	695	658	508,0	8,8	101	72,0	0	199,0	223,0	220-10-101-0500
500	1445	695	988	508,0	8,8	150	32,0	0	152,0	264,0	220-10-150-0500
500	1795	695	1338	508,0	8,8	200	18,0	0	122,0	307,0	220-10-200-0500

\*l = Mittenabstand / center distance

Weitere Abmessungen und Werkstoffe auf Anfrage. /  
Other dimensions and materials on request.

**Typ 220 Abmessungen**  
**Ausführung 2**

**Type 220 Specifications**

**Model 2**

**Druckstufe 16 barg (PN 16)**  
**Design pressure 16 barg (PN 16)**

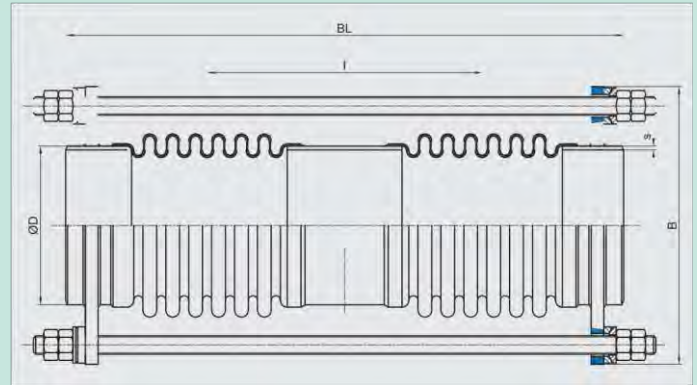

DN	Länge	Größte Breite Biggest width	Balg Bellow	Anschweißenden Weld ends		Bewegungsaufnahme Movement lateral	Verstellmomentrate Friction rate			Gewicht Weight	Artikel Article
	BL mm			B mm	l* mm		ØD mm	s mm	2λN mm		
50	510	145	215	60,3	2,9	51	16,0	0	3,2	4,9	220-16-051-0050
50	605	145	277	60,3	2,9	104	6,0	0	2,9	5,4	220-16-104-0050
50	715	145	387	60,3	2,9	153	3,1	0	2,4	6,1	220-16-153-0050
50	825	145	497	60,3	2,9	203	1,9	0	2,1	6,5	220-16-203-0050
65	510	155	215	76,1	2,9	50	24,0	0	5,0	5,2	220-16-050-0065
65	645	155	312	76,1	2,9	103	9,4	0	4,0	5,7	220-16-103-0065
65	765	155	432	76,1	2,9	150	5,0	0	3,4	6,6	220-16-150-0065
65	895	155	562	76,1	2,9	202	3,0	0	2,8	7,4	220-16-202-0065
80	505	185	212	88,9	3,2	51	37,0	0	8,9	7,5	220-16-051-0080
80	655	185	322	88,9	3,2	103	11,0	0	7,2	8,6	220-16-103-0080
80	785	185	452	88,9	3,2	153	5,3	0	6,0	9,7	220-16-153-0080
80	915	185	582	88,9	3,2	203	3,2	0	5,0	10,8	220-16-203-0080
100	570	215	215	114,3	3,6	51	46,0	0	13,0	9,8	220-16-051-0100
100	730	215	375	114,3	3,6	99	16,0	0	9,9	11,7	220-16-099-0100
100	890	215	535	114,3	3,6	150	7,8	0	8,0	13,5	220-16-150-0100
100	1050	215	695	114,3	3,6	202	4,7	0	6,7	15,3	220-16-202-0100
125	600	245	295	139,7	4,0	50	70,0	0	17,0	15,4	220-16-050-0125
125	770	245	395	139,7	4,0	101	21,0	0	14,0	17,8	220-16-101-0125
125	930	245	555	139,7	4,0	151	11,0	0	12,0	20,2	220-16-151-0125
125	1090	245	715	139,7	4,0	202	6,5	0	9,4	22,7	220-16-202-0125
150	555	295	218	168,3	4,5	51	55,0	0	36,0	20,7	220-16-051-0150
150	725	295	388	168,3	4,5	101	18,0	0	27,0	24,4	220-16-101-0150
150	885	295	548	168,3	4,5	148	8,8	0	22,0	27,7	220-16-148-0150
150	1055	295	718	168,3	4,5	199	5,2	0	18,0	31,4	220-16-199-0150
200	600	365	230	219,1	6,3	52	110,0	0	63,0	38,2	220-16-052-0200
200	780	365	410	219,1	6,3	101	36,0	0	48,0	45,0	220-16-101-0200
200	960	365	590	219,1	6,3	152	18,0	0	39,0	51,7	220-16-152-0200
200	1170	365	800	219,1	6,3	202	9,3	0	32,0	59,9	220-16-202-0200
250	680	415	300	273,0	6,3	51	145,0	0	83,0	76,8	220-16-051-0250
250	930	415	550	273,0	6,3	101	44,0	0	60,0	89,6	220-16-101-0250
250	1190	415	810	273,0	6,3	150	21,0	0	46,0	103,0	220-16-150-0250
250	1480	415	1100	273,0	6,3	200	11,0	0	37,0	118,0	220-16-200-0250
300	730	470	315	323,9	7,1	51	119,0	0	109,0	92,7	220-16-051-0300
300	990	470	575	323,9	7,1	101	36,0	0	79,0	109,0	220-16-101-0300
300	1300	470	885	323,9	7,1	150	16,0	0	60,0	129,0	220-16-150-0300
300	1620	470	1205	323,9	7,1	201	8,3	0	48,0	149,0	220-16-201-0300
350	755	520	323	355,6	8,0	51	125,0	0	126,0	111,0	220-16-051-0350
350	1015	520	583	355,6	8,0	100	39,0	0	92,0	131,0	220-16-100-0350
350	1275	520	843	355,6	8,0	150	19,0	0	73,0	152,0	220-16-150-0350
350	1545	520	1113	355,6	8,0	201	11,0	0	60,0	173,0	220-16-201-0350

## Typ 220 Abmessungen Ausführung 2

## Type 220 Specifications

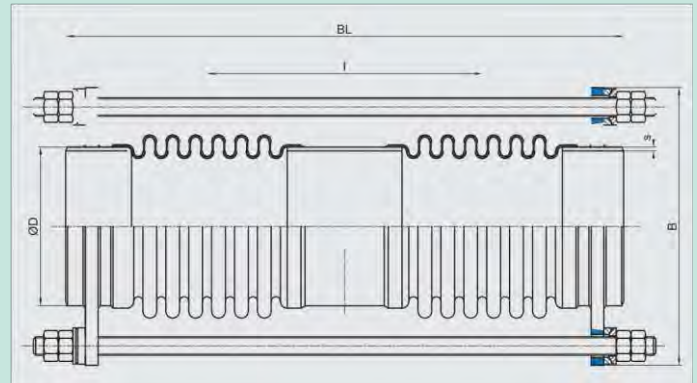

400	860	585	370	406,4	8,8	50	330,0	0	165,0	183,0	220-16-050-0400
400	1075	585	543	406,4	8,8	100	91,0	0	131,0	195,0	220-16-100-0400
400	1305	585	773	406,4	8,8	150	46,0	0	108,0	218,0	220-16-150-0400
400	1535	585	1003	406,4	8,8	201	27,0	0	91,0	241,0	220-16-201-0400
450	840	645	335	457,0	8,8	50	249,0	0	215,0	204,0	220-16-050-0450
450	1110	645	605	457,0	8,8	100	78,0	0	161,0	234,0	220-16-100-0450
450	1370	645	865	457,0	8,8	149	39,0	0	130,0	262,0	220-16-149-0450
450	1630	645	1125	457,0	8,8	198	23,0	0	109,0	292,0	220-16-198-0450

\*I = Mittenabstand / center distance

Weitere Abmessungen und Werkstoffe auf Anfrage. /  
Other dimensions and materials on request.

## Model 2

### Druckstufe 25 barg (PN 25)

### Design pressure 25 barg (PN 25)

DN	Länge	Größte Breite Biggest width	Balg Bellow	Anschweißenden Weld ends		Bewegungsaufnahme Movement lateral	Verstellmomentrate Friction rate			Gewicht Weight kg	Artikel Article
	BL mm			B mm	I* mm		ØD mm	s mm	2λN mm		
50	510	145	215	60,3	4,0	50	16,0	0	3,2	5,5	220-25-050-0050
50	700	145	405	60,3	4,0	101	4,5	0	2,3	6,8	220-25-101-0050
50	880	145	585	60,3	4,0	150	2,2	0	1,8	8,2	220-25-150-0050
50	1060	145	765	60,3	4,0	200	1,3	0	1,5	9,6	220-25-200-0050
65	520	155	225	76,1	4,0	52	22,0	0	5,0	6,0	220-25-052-0065
65	695	155	362	76,1	4,0	101	7,0	0	3,7	6,9	220-25-101-0065
65	845	155	512	76,1	4,0	150	3,6	0	3,0	8,4	220-25-150-0065
65	995	155	662	76,1	4,0	200	2,2	0	2,5	9,7	220-25-200-0065
80	505	185	212	88,9	4,0	50	37,0	0	8,9	8,2	220-25-050-0080
80	685	185	392	88,9	4,0	100	11,0	0	6,2	9,9	220-25-100-0080
80	875	185	582	88,9	4,0	151	5,1	0	4,8	11,9	220-25-151-0080
80	1085	185	792	88,9	4,0	202	2,8	0	3,8	14,0	220-25-202-0080
100	645	235	323	114,3	4,0	50	40,0	0	14,0	14,7	220-25-050-0100
100	925	235	603	114,3	4,0	99	12,0	0	9,1	18,8	220-25-099-0100
100	1205	235	883	114,3	4,0	150	5,3	0	6,9	22,6	220-25-150-0100
100	1485	235	1163	114,3	4,0	200	3,1	0	5,6	26,7	220-25-200-0100
125	640	260	305	139,7	4,0	51	65,0	0	20,0	29,2	220-25-051-0125
125	900	260	565	139,7	4,0	101	20,0	0	14,0	33,9	220-25-101-0125
125	1160	260	825	139,7	4,0	151	9,0	0	11,0	38,8	220-25-151-0125



## Typ 220 Abmessungen Ausführung 2

### Type 220 Specifications

125	1410	260	1075	139,7	4,0	200	5,3	0	8,6	43,4	220-25-200-0125
150	710	310	325	168,3	4,5	49	144,0	0	31,0	46,0	220-25-049-0150
150	990	310	605	168,3	4,5	100	42,0	0	22,0	53,2	220-25-100-0150
150	1260	310	875	168,3	4,5	149	21,0	0	17,0	60,2	220-25-149-0150
150	1540	310	1155	168,3	4,5	201	12,0	0	14,0	67,4	220-25-201-0150
200	705	360	257	219,1	6,3	50	223,0	0	56,0	63,7	220-25-050-0200
200	915	360	467	219,1	6,3	101	73,0	0	42,0	72,1	220-25-101-0200
200	1105	360	657	219,1	6,3	150	37,0	0	35,0	79,9	220-25-150-0200
200	1295	360	847	219,1	6,3	200	23,0	0	30,0	87,7	220-25-200-0200
250	690	415	310	273,0	7,1	50	136,0	0	82,0	80,0	220-25-050-0250
250	950	415	570	273,0	7,1	100	41,0	0	59,0	94,6	220-25-100-0250
250	1260	415	880	273,0	7,1	150	18,0	0	44,0	113,0	220-25-150-0250
250	1570	415	1190	273,0	7,1	199	9,4	0	35,0	130,0	220-25-199-0250
300	930	485	315	323,9	8,0	50	439,0	0	102,0	151,0	220-25-050-0300
300	1180	485	565	323,9	8,0	99	150,0	0	80,0	170,0	220-25-099-0300
300	1420	485	805	323,9	8,0	151	76,0	0	66,0	188,0	220-25-151-0300
300	1640	485	1025	323,9	8,0	200	48,0	0	57,0	205,0	220-25-200-0300
350	845	530	358	355,6	8,0	51	182,0	0	127,0	152,0	220-25-051-0350
350	1135	530	647	355,6	8,0	100	57,0	0	94,0	176,0	220-25-100-0350
350	1445	530	957	355,6	8,0	150	26,0	0	74,0	202,0	220-25-150-0350
350	1785	530	1297	355,6	8,0	200	15,0	0	59,0	230,0	220-25-200-0350

\*l = Mittenabstand / center distance

Weitere Abmessungen und Werkstoffe auf Anfrage. /  
Other dimensions and materials on request.

## Typ 220 Abmessungen Ausführung 2

## Type 220 Specifications Model 2

### Druckstufe 40 barg (PN 40) Design pressure 40 barg (PN 40)

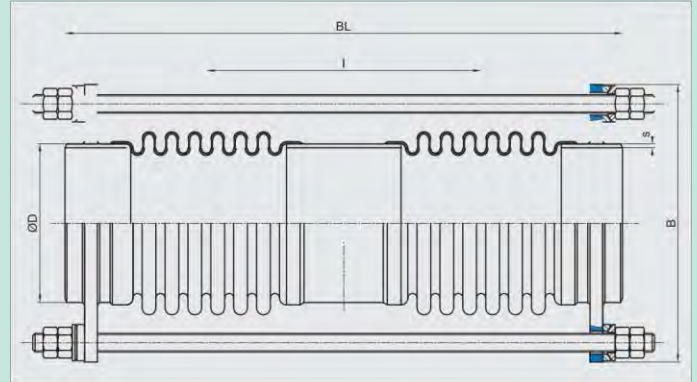

DN	Länge Length BL mm	Größte Breite Biggest width B mm	Balg Bellows l* mm	Anschweißenden Weld ends		Bewegungsaufnahme Movement lateral 2λ <sub>w</sub> mm	Verstellmomentrate Friction rate			Gewicht Weight kg	Artikel Article
				ØD mm	s mm		CA N/mm	Cp N/mm barg	Cr N/barg		
50	520	145	225	60,3	4,0	51	15,0	0	3,1	5,6	220-40-051-0050
50	710	145	415	60,3	4,0	100	4,3	0	2,3	6,8	220-40-100-0050
50	940	145	645	60,3	4,0	151	1,8	0	1,6	8,7	220-40-151-0050
50	1160	145	865	60,3	4,0	200	1,0	0	1,3	10,1	220-40-200-0050
65	550	175	225	76,1	4,0	50	22,0	0	5,8	8,9	220-40-050-0065
65	740	175	415	76,1	4,0	100	6,5	0	4,2	10,9	220-40-100-0065
65	970	175	645	76,1	4,0	152	2,7	0	3,2	13,3	220-40-152-0065
65	1190	175	865	76,1	4,0	200	1,5	0	2,6	15,5	220-40-200-0065
80	535	210	222	88,9	4,0	50	34,0	0	11,0	17,2	220-40-050-0080
80	725	210	412	88,9	4,0	101	10,0	0	7,4	19,7	220-40-101-0080
80	945	210	632	88,9	4,0	151	4,3	0	5,6	22,5	220-40-151-0080
80	1165	210	852	88,9	4,0	200	2,4	0	4,5	25,5	220-40-200-0080
100	655	235	333	114,3	4,0	50	38,0	0	14,0	14,9	220-40-050-0100
100	975	235	653	114,3	4,0	100	9,7	0	8,7	19,5	220-40-100-0100
100	1325	235	1003	114,3	4,0	150	4,2	0	6,3	24,3	220-40-150-0100
100	1665	235	1343	114,3	4,0	200	2,3	0	5,0	29,0	220-40-200-0100
125	650	260	315	139,7	4,0	50	61,0	0	20,0	29,6	220-40-050-0125
125	930	260	595	139,7	4,0	100	18,0	0	14,0	34,6	220-40-100-0125
125	1260	260	925	139,7	4,0	151	7,2	0	9,7	40,5	220-40-151-0125
125	1570	260	1235	139,7	4,0	200	4,0	0	7,7	46,1	220-40-200-0125
150	720	310	335	168,3	4,5	50	136,0	0	30,0	46,5	220-40-050-0150
150	1010	310	625	168,3	4,5	101	40,0	0	21,0	53,9	220-40-101-0150
150	1310	310	925	168,3	4,5	149	19,0	0	16,0	61,4	220-40-149-0150
150	1640	310	1255	168,3	4,5	199	9,8	0	13,0	69,8	220-40-199-0150
200	825	375	407	219,1	6,3	50	162,0	0	51,0	86,7	220-40-050-0200
200	1185	375	767	219,1	6,3	99	46,0	0	35,0	103,0	220-40-099-0200
200	1545	375	1127	219,1	6,3	150	22,0	0	27,0	119,0	220-40-150-0200
200	1905	375	1487	219,1	6,3	200	13,0	0	22,0	134,0	220-40-200-0200
250	865	435	423	273,0	7,1	50	293,0	0	74,0	117,0	220-40-050-0250
250	1235	435	793	273,0	7,1	101	84,0	0	52,0	140,0	220-40-101-0250
250	1595	435	1153	273,0	7,1	151	40,0	0	40,0	161,0	220-40-151-0250
250	1955	435	1513	273,0	7,1	201	24,0	0	32,0	183,0	220-40-201-0250

\*l = Mittenabstand / center distance

Weitere Abmessungen und Werkstoffe auf Anfrage. /  
Other dimensions and materials on request.

## Typ 220 Abmessungen Ausführung 2

## Type 220 Specifications

### Model 2

Druckstufe 63 barg (PN 63)  
Design pressure 63 barg (PN 63)

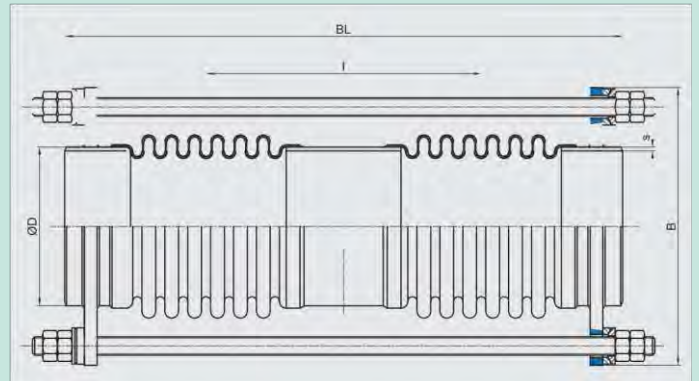

DN	Länge Length	Größte Breite Biggest width	Balg Bellows	Anschweißenden Weld ends		Bewegungsaufnahme Movement lateral	Verstellmomentrate Friction rate			Gewicht Weight kg	Artikel Article
	BL mm	B mm	l* mm	ØD mm	s mm		2λN mm	CA N/mm	Cp N/mm barg		
50	540	145	245	60,3	4,0	49	13,0	0	3,0	5,7	220-63-049-0050
50	760	145	465	60,3	4,0	100	3,4	0	2,1	7,3	220-63-100-0050
50	1010	145	715	60,3	4,0	151	1,5	0	1,5	9,1	220-63-151-0050
50	1250	145	955	60,3	4,0	200	0,8	0	1,2	10,8	220-63-200-0050
65	600	175	275	76,1	4,0	49	19,0	0	5,7	9,5	220-63-049-0065
65	840	175	515	76,1	4,0	99	5,3	0	4,0	11,8	220-63-099-0065
65	1110	175	785	76,1	4,0	150	2,3	0	2,9	14,7	220-63-150-0065
65	1390	175	1065	76,1	4,0	201	1,3	0	2,3	17,5	220-63-201-0065
80	605	210	292	88,9	4,0	51	29,0	0	9,7	18,1	220-63-051-0080
80	855	210	542	88,9	4,0	102	8,3	0	6,7	21,4	220-63-102-0080
80	1125	210	812	88,9	4,0	150	3,7	0	5,0	24,9	220-63-150-0080
80	1415	210	1102	88,9	4,0	201	2,1	0	3,9	28,8	220-63-201-0080
100	685	230	353	114,3	5,0	50	34,0	0	13,0	25,7	220-63-050-0100
100	1065	230	733	114,3	5,0	101	7,7	0	7,9	32,6	220-63-101-0100
100	1445	230	1113	114,3	5,0	150	3,4	0	5,7	39,5	220-63-150-0100
100	1825	230	1493	114,3	5,0	200	1,9	0	4,5	46,5	220-63-200-0100
125	700	275	335	139,7	6,3	50	54,0	0	22,0	42,8	220-63-050-0125

\*l = Mittenabstand / center distance

Weitere Abmessungen und Werkstoffe auf Anfrage.  
Other dimensions and materials on request.

125	1040	275	675	139,7	6,3	101	14,0	0	15,0	52,3	220-63-101-0125
125	1390	275	1025	139,7	6,3	150	5,8	0	11,0	62,2	220-63-150-0125
125	1750	275	1385	139,7	6,3	200	3,2	0	8,4	72,4	220-63-200-0125
150	780	320	355	168,3	6,3	51	121,0	0	32,0	62,3	220-63-051-0150
150	1070	320	645	168,3	6,3	100	37,0	0	23,0	72,9	220-63-100-0150
150	1420	320	995	168,3	6,3	150	16,0	0	18,0	85,3	220-63-150-0150
150	1770	320	1345	168,3	6,3	200	8,6	0	14,0	98,0	220-63-200-0150
200	875	380	437	219,1	8,0	50	141,0	0	48,0	113,0	220-63-050-0200
200	1305	380	867	219,1	8,0	100	36,0	0	32,0	137,0	220-63-100-0200
200	1765	380	1327	219,1	8,0	150	16,0	0	24,0	162,0	220-63-150-0200
200	2215	380	1777	219,1	8,0	200	8,6	0	19,0	187,0	220-63-200-0200

## Lateralkompensator mit Losflanschen und Zugstangen Typ 222 Typ 223 (mit Innenleitrohr)

Der Typ 222 ist ein mehrwelliger Lateralkompensator mit Losflanschen. Die Zugstangenverspannung ist auf die Anschlüsse aufgeschweißt.

Er ist speziell konzipiert für den Betrieb in Anlagen mit Betriebsdrücken bis 25 barg.

Dieser Kompensator lässt ausschließlich laterale Bewegungen zu.

### Beschreibung

Neben den aufgeführten Standardbaulängen kann die Baulänge speziell auf Ihre Bedürfnisse angepasst gefertigt werden. Dieser Kompensator kann auch in anderen Werkstoffen (siehe Seite 179) gefertigt werden.

### Ausführung

Zur Realisierung größerer Kompensatorenbaulängen ist die Variante mit einem eingeschweißten Zwischenrohr (Ausführung 2) erhältlich. Bei Vakuumbetrieb auch zuzüglich innerer Zugverspannung.

### Vorteile

- Aufnahme von Bewegungen in sämtlichen laterale Richtung
- Aufnahme großer lateraler Bewegungen mit nur einem Lateralkompensator
- Aufnahme der Reaktionskräfte über die Zuganker

## Lateral expansion joint with loose flanges and tie rods

### Type 222

### Type 223 (with internal sleeve)



Type 222 is a multi-layer lateral expansion joint with loose flanges. This expansion joint has a hinge construction.

It is designed specifically for operation in installations with operating pressures up to 25 barg.

This expansion joint only allows lateral movements.

### Description

In addition to the specified standard lengths, other lengths are available to meet specific requirements. This expansion joint can also be produced in other materials (see page 179).

### Versions

For longer expansion joint lengths, a version with a welded intermediate pipe is available (version 2). For vacuum operation also additional lock nuts are available.

For large lateral movements with only one lateral expansion joint

▫ Absorption of the reaction forces via the tie rods

▫

## Lateralkompensator

### Lateral expansion

#### mit Losflanschen und Zugstangen

#### joint with loose flanges and

#### Typ 222

#### tie rods

#### Typ 223 (mit Innenleitrohr)

#### Type 222

#### Type 223 (with internal sleeve)

<b>Einsatzbeispiele</b>	Dampfanlagen, Wasser, Entwässerung etc.
<b>Aufbau</b>	Mehrlagiger Wellrohrbalg aus 1.4541 mit Losflanschen und Verspannung aus C-Stahl.
<b>Zulässige Betriebsdaten (Standard)</b>	16 barg / 120 °C gem, EJMA Höhere Drücke auf Anfrage.
<b>Zubehör</b>	Innenleitrohr, Außenschutzrohr
<b>Hinweis</b>	Bei Verwendung von Leitrohren vermindert sich der Balgquerschnitt. Bitte beachten Sie bei Ihrer Planung die Medienverträglichkeit der zu verwendenden Kompensatorenmaterialien.

<b>Application examples</b>	Steam plants, water, drainage, etc.
<b>Standard design</b>	Multi-layer corrugated tube bellows of 1.4541 with loose flanges and tie rods of carbon steel.
<b>Permissible operating data</b>	16 barg / 120 °C acc. to EJMA Higher pressures on request.
<b>Accessories</b>	Internal sleeve, external protective sleeve
<b>Note</b>	Using internal sleeves will reduce the bellows cross-section. To be noted is that the media compatibility of the expansion joint material to be used should be taken into account in the planning phase.

**Ausführung 1 / Model 1**



**Ausführung 2 / Model 2**



**Typ 222 Abmessungen  
Ausführung 1**

**Versions  
Type 222  
Model 1**

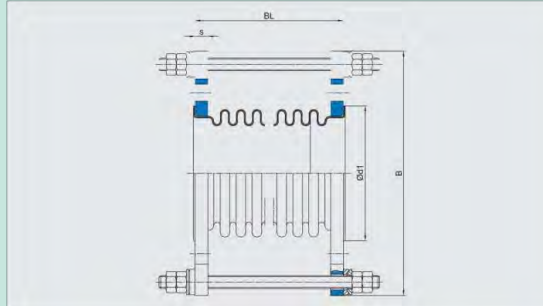

**Ausführungsvarianten /  
Specifications**

**Druckstufe 6 barg (PN 6)  
Design pressure 6 barg (PN 6)**

DN	Länge	Größte Breite Biggest width	Flansch Flan <sup>ges</sup>		Bewegungsaufnahme Movement lateral	Verstellmomentrate Friction rate			Gewicht Weight kg	Artikel Article
	Length		BL mm	B mm		Ød1 mm	s mm	2ΔN mm		
50	155	226	90	17	16	47	0	8,9	5,6	222-06-016-0050
50	255	226	90	17	43	11	0	6,0	6,5	222-06-043-0050
65	145	246	107	17	12	84	0	16,0	6,5	222-06-012-0065
65	215	246	107	17	32	27	0	12,0	7,1	222-06-032-0065
80	145	276	122	17	6	285	0	27,0	8,4	222-06-006-0080
80	190	276	122	17	15	62	0	22,0	8,8	222-06-015-0080
80	255	276	122	17	33	40	0	17,0	9,9	222-06-033-0080
100	155	296	147	17	6	293	0	42,0	9,2	222-06-006-0100
100	195	296	147	17	16	129	0	35,0	10,0	222-06-016-0100
100	280	296	147	17	39	59	0	26,0	12,2	222-06-039-0100
125	165	326	178	22	5	491	0	58,0	13,4	222-06-005-0125
125	215	326	178	22	16	150	0	47,0	14,4	222-06-016-0125
125	315	326	178	22	40	75	0	33,0	17,7	222-06-040-0125

Weitere Abmessungen und Werkstoffe auf Anfrage. /  
Other dimensions and materials on request.

## Typ 222 Abmessungen

### Ausführung 1

150	180	351	202	22	5	644	0	78,0	14,6	222-06-005-0150
150	260	351	202	22	21	217	0	57,0	16,9	222-06-021-0150
150	370	351	202	22	50	91	0	42,0	21,4	222-06-050-0150
200	185	406	258	22	7	557	0	123,0	18,7	222-06-007-0200
200	275	406	258	22	22	223	0	90,0	22,1	222-06-022-0200
200	330	406	258	22	39	191	0	76,0	26,8	222-06-039-0200
250	185	461	312	22	5	1280	0	185,0	21,9	222-06-005-0250
250	275	461	312	22	19	408	0	136,0	26,1	222-06-019-0250
250	370	461	312	22	33	210	0	104,0	31,3	222-06-033-0250
300	210	526	365	27	5	1940	0	235,0	36,8	222-06-005-0300
300	245	526	365	27	12	624	0	206,0	38,0	222-06-012-0300
300	310	526	365	27	24	450	0	171,0	44,9	222-06-024-0300
350	200	576	410	27	5	2670	0	291,0	45,5	222-06-005-0350
350	245	576	410	27	11	697	0	248,0	47,8	222-06-011-0350
350	345	576	410	27	25	412	0	186,0	56,3	222-06-025-0350
400	250	642	465	27	7	1600	0	376,0	53,5	222-06-007-0400
400	310	642	465	27	17	628	0	319,0	59,3	222-06-017-0400
400	460	642	465	27	38	365	0	225,0	75,2	222-06-038-0400
450	230	697	520	27	4	5050	0	509,0	61,7	222-06-004-0450
450	285	697	520	27	12	1230	0	432,0	64,8	222-06-012-0450

## Typ 222 Abmessungen Ausführung 1

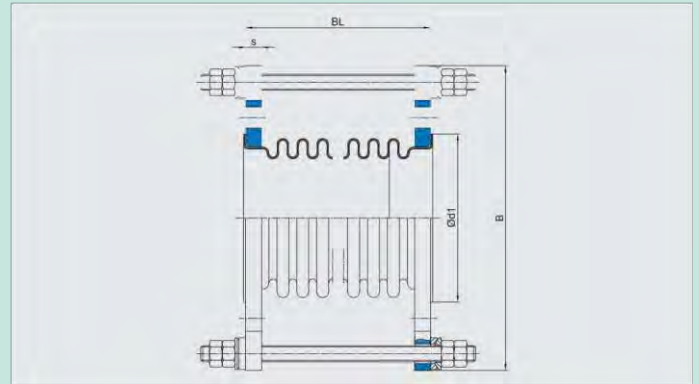

450	415	697	520	27	31	532	0	312,0	84,5	222-06-031-0450
500	265	747	570	32	5	4760	0	563,0	76,4	222-06-005-0500
500	360	747	570	32	16	900	0	435,0	80,1	222-06-016-0500
500	465	747	570	32	33	584	0	349,0	102,0	222-06-033-0500

## Type 222 Specifications Model 1

**Druckstufe 10 barg (PN 10)**  
Design pressure 10 barg (PN 10)

DN	Länge Length	Größte Breite Biggest width	Flansch Flanges		Bewegungsaufnahme Movement lateral	Verstellmomentrate Friction rate			Gewicht Weight kg	Artikel Article
	BL mm		B mm	Ød1 mm		s mm	2λN mm	Cλ N/mm		
50	140	251	92	18	11	81	0	9,6	7,5	222-10-011-0050

Weitere Abmessungen und Werkstoffe auf Anfrage./  
Other dimensions and materials on request.



**Typ 222 Abmessungen**  
**Ausführung 1**

50	205	251	92	18	25	27	0	7,2	8,1	222-10-025-0050
65	145	271	107	22	9	132	0	16,0	9,9	222-10-009-0065
65	215	271	107	22	21	39	0	12,0	10,5	222-10-021-0065
80	155	286	122	22	5	327	0	26,0	11,1	222-10-005-0080
80	240	286	122	22	26	117	0	18,0	12,6	222-10-026-0080
80	265	286	122	22	26	64	0	17,0	12,6	222-10-026-0080
100	160	306	147	22	6	491	0	40,0	12,7	222-10-006-0100
100	195	306	147	22	12	174	0	34,0	13,0	222-10-012-0100
100	295	306	147	22	30	90	0	24,0	15,4	222-10-030-0100
125	155	336	178	22	4	557	0	60,0	14,6	222-10-004-0125
125	195	336	178	22	11	264	0	49,0	15,4	222-10-011-0125
125	280	336	178	22	25	140	0	37,0	18,2	222-10-025-0125
150	170	371	208	27	3	1920	0	80,0	21,1	222-10-003-0150
150	255	371	208	27	15	254	0	59,0	23,0	222-10-015-0150
150	350	371	208	27	31	159	0	43,0	25,0	222-10-031-0150
200	190	426	258	27	4	2800	0	120,0	27,5	222-10-004-0200
200	235	426	258	27	12	494	0	104,0	28,9	222-10-012-0200
200	305	426	258	27	24	315	0	81,0	33,1	222-10-024-0200
250	190	497	320	27	3	4620	0	215,0	34,3	222-10-003-0250
250	235	497	320	27	10	906	0	185,0	35,5	222-10-010-0250

## Typ 222 Abmessungen Ausführung 1

250	325	497	320	27	23	456	0	139,0	42,6	222-10-023-0250
300	190	531	370	27	3	5800	0	256,0	39,5	222-10-003-0300
300	275	531	370	27	14	796	0	190,0	44,5	222-10-014-0300
300	355	531	370	27	26	561	0	153,0	55,6	222-10-026-0300
350	190	607	410	27	3	7990	0	357,0	54,0	222-10-003-0350
350	245	607	410	27	10	1490	0	299,0	59,5	222-10-010-0350
350	320	607	410	27	19	768	0	235,0	64,9	222-10-019-0350
400	210	683	465	32	3	11500	0	492,0	78,1	222-10-003-0400
400	330	683	465	32	15	1010	0	346,0	84,4	222-10-015-0400
400	400	683	465	32	27	834	0	293,0	97,3	222-10-027-0400
450	255	733	520	32	6	4770	0	529,0	87,1	222-10-006-0450
450	320	733	520	32	15	1840	0	448,0	96,1	222-10-015-0450
450	455	733	520	32	32	853	0	332,0	121,0	222-10-032-0450
500	230	788	570	37	2	31200	0	704,0	107,0	222-10-002-0500
500	315	788	570	37	10	3440	0	556,0	116,0	222-10-010-0500
500	435	788	570	37	25	1180	0	425,0	130,0	222-10-025-0500

**Typ 222 Abmessungen  
Ausführung 1**

**Type 222 Specifications**

**Model 1**

**Druckstufe 16  
Design pressure**

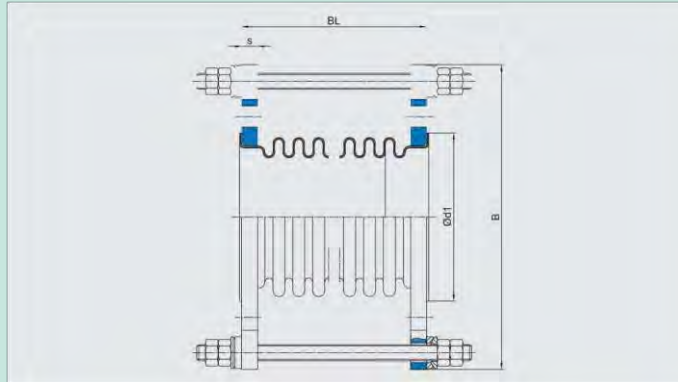

**barg (PN 16)  
16 barg (PN 16)**

DN	Länge Length	Größe Breite Biggest width		Flansch Flanges		Bewegungsaufnahme Movement lateral	Verstellmomentrate Friction rate			Gewicht Weight kg	Artikel Article
	BL mm	B mm	Ød1 mm	s mm	2λN mm	Cλ N/mm	Cp N/mm barg	Cr N/barg			
50	140	251	92	18	9	81	0	9,6	7,5	222-16-009-0050	
50	215	251	92	18	25	40	0	6,8	8,3	222-16-025-0050	
65	145	271	107	22	8	132	0	16,0	9,9	222-16-008-0065	
65	220	271	107	22	24	62	0	12,0	11,1	222-16-024-0065	
80	155	286	122	22	5	327	0	26,0	11,1	222-16-005-0080	
80	240	286	122	22	19	117	0	18,0	12,6	222-16-019-0080	
100	160	306	147	22	6	491	0	40,0	12,7	222-16-006-0100	
100	210	306	147	22	13	249	0	32,0	13,8	222-16-013-0100	
125	150	336	178	22	2	1820	0	61,0	14,7	222-16-002-0125	
125	190	336	178	22	9	472	0	52,0	16,0	222-16-009-0125	
125	225	336	178	22	14	306	0	45,0	17,5	222-16-014-0125	

Other dimensions and materials on request.

## Typ 222 Abmessungen Ausführung 2

### Type 222 Specifications

150	175	371	208	27	3	3100	0	79,0	21,6	222-16-003-0150
150	205	371	208	27	7	780	0	71,0	22,2	222-16-007-0150
150	275	371	208	27	17	356	0	54,0	25,0	222-16-017-0150
200	180	442	258	27	3	4970	0	149,0	29,3	222-16-003-0200
200	245	442	258	27	11	716	0	116,0	31,2	222-16-011-0200
200	340	442	258	27	24	440	0	87,0	38,1	222-16-024-0200
250	215	507	320	27	4	3620	0	193,0	39,5	222-16-004-0250
250	255	507	320	27	10	1300	0	171,0	42,5	222-16-010-0250
250	360	507	320	27	22	629	0	126,0	51,0	222-16-022-0250
300	200	562	375	32	2	16300	0	285,0	53,7	222-16-002-0300
300	255	562	375	32	8	2620	0	239,0	58,6	222-16-008-0300
300	345	562	375	32	18	910	0	185,0	69,3	222-16-018-0300
350	205	638	410	32	2	12000	0	376,0	73,0	222-16-002-0350
350	245	638	410	32	7	3660	0	333,0	77,2	222-16-007-0350
350	345	638	410	32	17	1130	0	253,0	89,5	222-16-017-0350
400	250	698	465	37	4	9800	0	430,0	105,0	222-16-004-0400
400	310	698	465	37	10	2710	0	362,0	109,0	222-16-010-0400
400	345	698	465	37	15	1610	0	335,0	116,0	222-16-015-0400
450	250	758	520	37	3	15600	0	535,0	119,0	222-16-003-0450
450	310	758	520	37	9	3950	0	452,0	123,0	222-16-009-0450
450	345	758	520	37	15	2220	0	418,0	131,0	222-16-015-0450

Weitere Abmessungen und Werkstoffe auf Anfrage. /

**Typ 222 Abmessungen  
Ausführung 1**

**Type 222 Specifications  
Model 1**

**Druckstufe 25 barg (PN 25)  
Design pressure 25 barg (PN 25)**

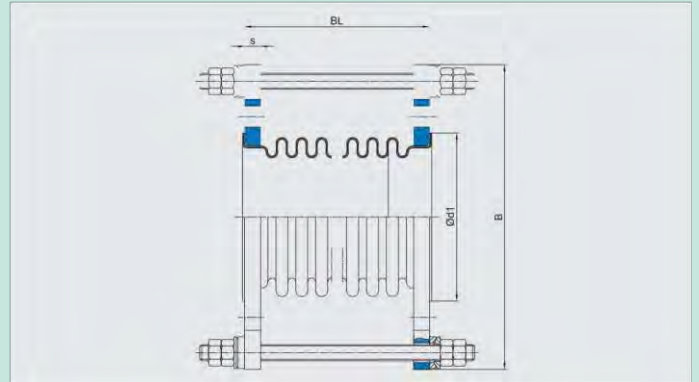

DN	Länge	Größte Breite	Flansch		Bewegungsaufnahme Movement lateral	Verstellmomentrate			Gewicht	Artikel
	Length	Biggest width	Flan <sup>g</sup> es	Flan <sup>g</sup> es		Friction rate				
	BL	B	Ød1	s	2λN	Cλ	Cp	Cr	kg	
	mm	mm	mm	mm	mm	N/mm	N/mm barg	N/barg		
50	140	251	92	22	6	109	0	9,6	8,8	222-25-006-0050
50	195	251	92	22	16	73	0	7,3	9,4	222-25-016-0050
65	140	271	107	22	6	195	0	16,0	9,9	222-25-006-0065
65	235	271	107	22	21	82	0	9,9	11,3	222-25-021-0065
80	165	286	122	22	6	390	0	24,0	11,5	222-25-006-0080
80	215	286	122	22	12	208	0	19,0	12,4	222-25-012-0080
100	165	321	147	27	4	1060	0	39,0	17,3	222-25-004-0100
100	220	321	147	27	10	339	0	30,0	18,1	222-25-010-0100
125	190	356	178	27	6	858	0	51,0	21,4	222-25-006-0125
125	230	356	178	27	12	525	0	43,0	23,7	222-25-012-0125
150	200	402	208	32	3	3670	0	83,0	30,4	222-25-003-0150

## Typ 222 Abmessungen Ausführung 2

### Type 222 Specifications

150	265	402	208	32	12	661	0	65,0	33,2	222-25-012-0150
200	195	478	258	32	3	7580	0	154,0	41,4	222-25-003-0200
200	250	478	258	32	9	1160	0	129,0	44,1	222-25-009-0200
250	195	543	320	32	2	16700	0	232,0	55,7	222-25-002-0250
250	250	543	320	32	7	2540	0	194,0	59,1	222-25-007-0250
250	320	543	320	32	13	1270	0	161,0	64,1	222-25-013-0250
300	225	604	375	37	3	12700	0	289,0	80,6	222-25-003-0300
300	275	604	375	37	7	3300	0	248,0	83,4	222-25-007-0300
300	300	604	375	37	11	2090	0	238,0	88,8	222-25-011-0300
350	235	673	410	42	2	17700	0	334,0	117,0	222-25-002-0350
350	285	673	410	42	6	4590	0	288,0	120,0	222-25-006-0350
350	315	673	410	42	10	2700	0	272,0	126,0	222-25-010-0300

Weitere Abmessungen und Werkstoffe auf Anfrage.  
/ Other dimensions and materials on request.

**Typ 222 Abmessungen**  
**Ausführung 1**

**Type 222 Specifications**  
**Model 2**

**Druckstufe 6 barg (PN 6)**  
**Design pressure 6 barg (PN 6)**

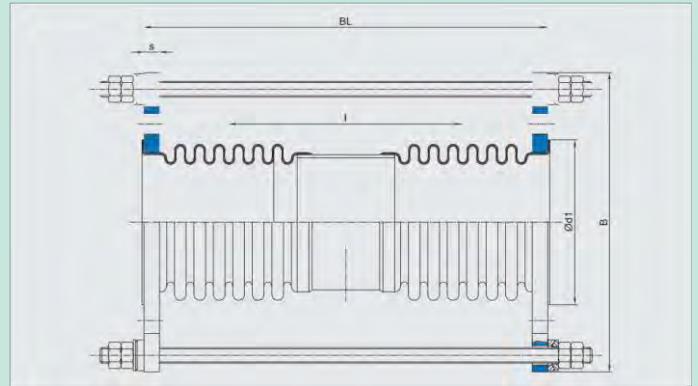

DN	Länge	Größte Breite	Balg	Flansch		Bewegungsaufnahme	Verstellmomentrate			Gewicht	Artikel
	Length	Biggest width	Bellow	Flanges			Friction rate				
	BL	B	I*	Ød1	s	2λN	CA	Cp	Cr	kg	
	mm	mm	mm	mm	mm	mm	N/mm	N/mm barg	N/barg		
50	295	226	167	90	17	63	3,9	0	5,3	6,8	222-06-063-0050
50	375	226	247	90	17	101	1,9	0	4,3	7,3	222-06-101-0050
50	475	226	347	90	17	149	1,0	0	3,5	7,9	222-06-149-0050
50	575	226	447	90	17	199	0,6	0	3,0	8,7	222-06-199-0050
65	305	246	173	107	17	61	6,5	0	8,1	7,9	222-06-061-0065
65	395	246	263	107	17	100	2,9	0	6,5	8,6	222-06-100-0065
65	505	246	373	107	17	150	1,5	0	5,2	9,6	222-06-150-0065
65	615	246	483	107	17	202	0,9	0	4,5	10,6	222-06-202-0065
80	305	276	165	122	17	64	15,0	0	15,0	10,4	222-06-064-0080
80	385	276	245	122	17	103	6,6	0	12,0	11,2	222-06-103-0080
80	485	276	345	122	17	153	3,3	0	9,6	12,2	222-06-153-0080
80	575	276	435	122	17	199	2,1	0	8,2	13,0	222-06-199-0080
100	285	296	154	147	17	58	33,0	0	25,0	12,3	222-06-058-0100
100	375	296	244	147	17	100	13,0	0	20,0	13,6	222-06-100-0100
100	485	296	354	147	17	153	5,9	0	16,0	15,1	222-06-153-0100
100	585	296	454	147	17	202	3,6	0	13,0	16,2	222-06-202-0100
125	335	326	200	178	22	51	29,0	0	32,0	16,7	222-06-051-0125
125	495	326	360	178	22	101	8,5	0	23,0	19,4	222-06-101-0125
125	655	326	520	178	22	152	4,0	0	18,0	21,9	222-06-152-0125
125	835	326	700	178	22	202	2,2	0	14,0	24,9	222-06-202-0125
150	315	351	170	202	22	51	48,0	0	49,0	18,2	222-06-051-0150
150	455	351	310	202	22	103	14,0	0	35,0	21,2	222-06-103-0150
150	585	351	440	202	22	153	6,6	0	28,0	23,9	222-06-153-0150
150	715	351	570	202	22	201	3,9	0	24,0	26,7	222-06-201-0150
200	360	406	197	258	22	52	83,0	0	71,0	26,6	222-06-052-0200
200	510	406	347	258	22	101	26,0	0	52,0	32,0	222-06-101-0200
200	660	406	497	258	22	153	13,0	0	41,0	37,3	222-06-153-0200
200	800	406	637	258	22	202	7,4	0	34,0	42,5	222-06-202-0200
250	390	461	227	312	22	51	106,0	0	100,0	32,5	222-06-051-0250
250	570	461	407	312	22	101	32,0	0	71,0	40,5	222-06-101-0250
250	740	461	577	312	22	150	16,0	0	56,0	48,2	222-06-150-0250
250	920	461	757	312	22	202	8,8	0	46,0	56,2	222-06-202-0250
300	405	526	235	365	27	52	122,0	0	135,0	51,5	222-06-052-0300
300	585	526	415	365	27	100	38,0	0	97,0	62,4	222-06-100-0300
300	765	526	595	365	27	150	18,0	0	76,0	73,2	222-06-150-0300
300	955	526	785	365	27	199	11,0	0	62,0	84,7	222-06-199-0300
350	430	576	257	410	27	50	139,0	0	153,0	62,1	222-06-050-0350
350	640	576	467	410	27	101	41,0	0	107,0	74,4	222-06-101-0350
350	840	576	667	410	27	150	20,0	0	83,0	86,2	222-06-150-0350
350	1070	576	897	410	27	201	11,0	0	66,0	99,9	222-06-201-0350

## Typ 222 Abmessungen Ausführung 2

### Type 222 Specifications

400	425	642	244	465	27	50	232,0	0	244,0	74,4	222-06-050-0400
400	625	642	444	465	27	101	67,0	0	173,0	88,4	222-06-101-0400
400	815	642	634	465	27	150	32,0	0	135,0	102,0	222-06-150-0400
400	1025	642	844	465	27	202	18,0	0	109,0	117,0	222-06-202-0400
450	465	697	244	520	27	51	226,0	0	280,0	86,0	222-06-051-0450
450	655	697	434	520	27	102	70,0	0	206,0	101,0	222-06-102-0450
450	825	697	604	520	27	149	36,0	0	167,0	114,0	222-06-149-0450
450	1005	697	784	520	27	200	21,0	0	139,0	128,0	222-06-200-0450
500	530	747	336	570	32	50	319,0	0	307,0	109,0	222-06-050-0500
500	820	747	626	570	32	101	86,0	0	206,0	134,0	222-06-101-0500
500	1090	747	896	570	32	149	41,0	0	158,0	157,0	222-06-149-0500
500	1370	747	1176	570	32	200	24,0	0	127,0	180,0	222-06-200-0500

\*l = Mittenabstand / center distance

Weitere Abmessungen und Werkstoffe auf Anfrage. /  
Other dimensions and materials on request.



**Typ 222 Abmessungen**  
**Ausführung 2**

**Type 222 Specifications**

**Model 2**

**Druckstufe 10 barg (PN 10)**  
**Design pressure 10 barg (PN 10)**

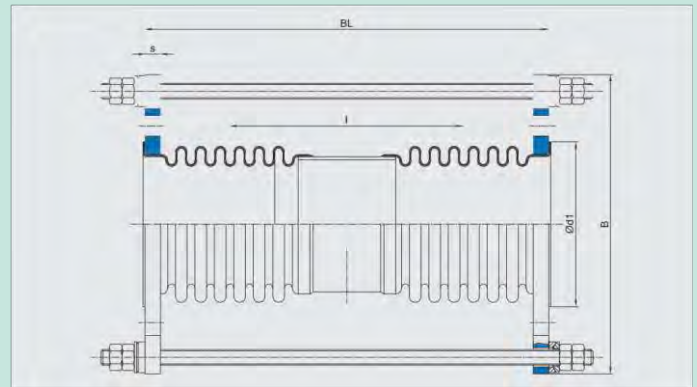

DN	Länge Length		Größte Breite Biggest width		Balg Bellows		Flansch Flanges			Bewegungsaufnahme Movement		Verstellmomentrate Friction rate			Gewicht Weight	Artikel Article
	BL mm	B mm	I* mm	Ød1	s mm	mm	2λN mm	CA N/mm	Cp N/mm barg	Cr N/barg	kg					
50	285	251	160	92	18	64	7,8	0	5,5	8,7	222-10-064-0050					
50	365	251	240	92	18	103	3,6	0	4,5	9,4	222-10-103-0050					
50	465	251	340	92	18	154	1,9	0	3,6	10,0	222-10-154-0050					
50	555	251	430	92	18	202	1,2	0	3,1	10,8	222-10-202-0050					
65	325	271	178	107	22	57	9,7	0	7,7	11,5	222-10-057-0065					
65	435	271	288	107	22	101	3,9	0	6,0	12,5	222-10-101-0065					
65	555	271	408	107	22	151	2,0	0	4,8	13,6	222-10-151-0065					
65	675	271	528	107	22	203	1,2	0	4,0	14,6	222-10-203-0065					
80	325	286	169	122	22	61	25,0	0	14,0	13,5	222-10-061-0080					
80	415	286	259	122	22	101	11,0	0	11,0	14,5	222-10-101-0080					
80	515	286	359	122	22	147	5,3	0	8,9	15,4	222-10-147-0080					
80	625	286	469	122	22	199	3,1	0	7,4	16,5	222-10-199-0080					
100	305	306	164	147	22	50	29,0	0	24,0	15,2	222-10-050-0100					
100	445	306	304	147	22	103	8,1	0	17,0	17,0	222-10-103-0100					
100	565	306	424	147	22	150	4,1	0	14,0	18,6	222-10-150-0100					
100	695	306	554	147	22	201	2,4	0	12,0	20,2	222-10-201-0100					
125	345	336	210	178	22	49	26,0	0	31,0	18,1	222-10-049-0125					
125	525	336	390	178	22	100	7,2	0	22,0	21,2	222-10-100-0125					
125	695	336	560	178	22	149	3,5	0	17,0	24,0	222-10-149-0125					
125	905	336	770	178	22	201	1,8	0	13,0	27,4	222-10-201-0125					
150	360	371	202	208	27	51	60,0	0	44,0	26,3	222-10-051-0150					
150	520	371	362	208	27	101	18,0	0	32,0	29,6	222-10-101-0150					
150	680	371	522	208	27	152	8,3	0	25,0	33,1	222-10-152-0150					
150	860	371	702	208	27	201	4,5	0	20,0	36,9	222-10-201-0150					
200	365	426	204	258	27	52	101,0	0	71,0	36,5	222-10-052-0200					
200	525	426	364	258	27	101	30,0	0	51,0	42,2	222-10-101-0200					
200	685	426	524	258	27	152	15,0	0	40,0	48,1	222-10-152-0200					
200	855	426	694	258	27	200	7,9	0	33,0	54,1	222-10-200-0200					
250	430	497	257	320	27	51	82,0	0	110,0	46,1	222-10-051-0250					
250	640	497	467	320	27	101	24,0	0	77,0	55,8	222-10-101-0250					
250	840	497	667	320	27	151	12,0	0	60,0	65,1	222-10-151-0250					
250	1040	497	867	320	27	201	6,7	0	50,0	74,4	222-10-201-0250					
300	465	531	299	370	27	51	155,0	0	118,0	58,8	222-10-051-0300					
300	705	531	539	370	27	100	45,0	0	81,0	73,3	222-10-100-0300					
300	975	531	809	370	27	150	20,0	0	60,0	89,4	222-10-150-0300					
300	1265	531	1099	370	27	200	11,0	0	47,0	107,0	222-10-200-0300					
350	460	607	287	410	27	50	111,0	0	173,0	71,7	222-10-050-0350					
350	700	607	527	410	27	100	32,0	0	118,0	86,5	222-10-100-0350					
350	930	607	757	410	27	149	15,0	0	91,0	101,0	222-10-149-0350					
350	1180	607	1007	410	27	200	8,4	0	73,0	117,0	222-10-200-0350					

## Typ 222 Abmessungen Ausführung 2

### Type 222 Specifications

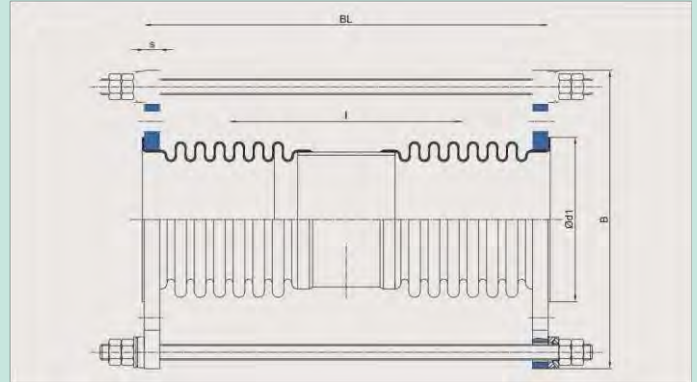

400	450	683	262	465	32	51	201,0	0	267,0	98,4	222-10-051-0400
400	665	683	474	465	32	101	58,0	0	190,0	114,0	222-10-101-0400
400	875	683	684	465	32	150	27,0	0	148,0	130,0	222-10-150-0400
400	1130	683	942	465	32	201	15,0	0	117,0	149,0	222-10-201-0400
450	515	733	299	520	32	50	363,0	0	295,0	124,0	222-10-050-0450
450	755	733	539	520	32	100	108,0	0	210,0	149,0	222-10-100-0450
450	995	733	779	520	32	152	51,0	0	163,0	175,0	222-10-152-0450
450	1225	733	1009	520	32	201	30,0	0	134,0	200,0	222-10-201-0450
500	560	788	356	570	37	50	282,0	0	338,0	147,0	222-10-050-0500
500	860	788	656	570	37	100	78,0	0	230,0	183,0	222-10-100-0500
500	1190	788	986	570	37	150	34,0	0	170,0	222,0	222-10-150-0500
500	1540	788	1336	570	37	200	19,0	0	133,0	264,0	222-10-200-0500

\*I = Mittenabstand / center distance

Weitere Abmessungen und Werkstoffe auf Anfrage. /  
Other dimensions and materials on request.

## Model 2

### Druckstufe 16 barg (PN 16)

#### Design pressure 16 barg (PN 16)

DN	Länge	Größe Breite	Balg	Flansch			Bewegungsaufnahme	Verstellmomentrate			Gewicht	Artikel
	Length	Biggest width	Bellow	Flanges			Movement lateral	Friction rate				
	BL	B	I*	Ød1	s	mm	2ΔN	C <sub>λ</sub>	C <sub>p</sub>	C <sub>r</sub>	kg	
	mm	mm	mm	mm	mm		mm	N/mm	N/mm barg	N/barg		
50	315	251	216	92	18	18	51	16,0	0	5,0	9,2	222-16-051-0050
50	495	251	396	92	18	18	100	4,7	0	3,4	10,6	222-16-100-0050
50	675	251	576	92	18	18	151	2,2	0	2,5	11,9	222-16-151-0050
50	855	251	756	92	18	18	201	1,3	0	2,0	13,0	222-16-201-0050
65	325	271	213	107	22	22	50	25,0	0	7,6	12,1	222-16-050-0065
65	505	271	393	107	22	22	100	7,2	0	5,2	13,7	222-16-100-0065
65	685	271	573	107	22	22	151	3,4	0	3,9	15,2	222-16-151-0065
65	855	271	743	107	22	22	200	2,1	0	3,2	16,5	222-16-200-0065
80	340	286	206	122	22	22	49	45,0	0	13,0	14,1	222-16-049-0080
80	520	286	386	122	22	22	101	13,0	0	8,7	15,9	222-16-101-0080

## Typ 222 Abmessungen Ausführung 2

### Type 222 Specifications

80	690	286	556	122	22	151	5,8	0	6,7	17,7	222-16-151-0080
80	860	286	726	122	22	201	3,4	0	5,5	19,4	222-16-201-0080
100	450	306	317	147	22	50	45,0	0	16,0	17,4	222-16-050-0100
100	730	306	597	147	22	101	13,0	0	11,0	20,9	222-16-101-0100
100	1000	306	867	147	22	150	5,7	0	7,6	24,6	222-16-150-0100
100	1270	306	1137	147	22	200	3,3	0	6,0	28,0	222-16-200-0100
125	440	336	301	178	22	51	74,0	0	24,0	22,1	222-16-051-0125
125	690	336	551	178	22	100	22,0	0	16,0	26,3	222-16-100-0125
125	940	336	801	178	22	150	9,9	0	12,0	30,4	222-16-150-0125
125	1190	336	1051	178	22	200	5,7	0	9,4	34,6	222-16-200-0125
150	375	371	209	208	27	50	74,0	0	42,0	27,5	222-16-050-0150
150	545	371	379	208	27	101	21,0	0	30,0	31,1	222-16-101-0150
150	715	371	549	208	27	152	9,5	0	24,0	34,6	222-16-152-0150
150	875	371	709	208	27	202	5,6	0	20,0	38,1	222-16-202-0150
200	395	442	228	258	27	51	131,0	0	77,0	40,1	222-16-051-0200
200	575	442	408	258	27	101	39,0	0	55,0	47,0	222-16-101-0200
200	755	442	588	258	27	151	19,0	0	43,0	53,8	222-16-151-0200
200	965	442	798	258	27	201	9,8	0	35,0	61,7	222-16-201-0200
250	465	507	299	320	27	51	168,0	0	101,0	56,0	222-16-051-0250
250	715	507	549	320	27	101	48,0	0	68,0	68,1	222-16-101-0250
250	975	507	809	320	27	150	22,0	0	51,0	80,7	222-16-150-0250
250	1265	507	1099	320	27	200	12,0	0	40,0	95,1	222-16-200-0250
300	485	562	309	375	32	50	144,0	0	137,0	73,0	222-16-050-0300
300	745	562	569	375	32	99	40,0	0	93,0	89,5	222-16-099-0300
300	1065	562	889	375	32	150	16,0	0	67,0	110,0	222-16-150-0300
300	1375	562	1199	375	32	200	8,7	0	52,0	129,0	222-16-200-0300
350	510	638	321	410	32	50	141,0	0	180,0	98,4	222-16-050-0350
350	780	638	591	410	32	101	41,0	0	123,0	120,0	222-16-101-0350
350	1040	638	851	410	32	150	20,0	0	95,0	141,0	222-16-150-0350
350	1300	638	1111	410	32	200	12,0	0	77,0	161,0	222-16-200-0350
400	585	698	373	465	37	51	369,0	0	207,0	145,0	222-16-051-0400
400	805	698	548	465	37	99	97,0	0	156,0	166,0	222-16-099-0400
400	1035	698	778	465	37	149	48,0	0	124,0	189,0	222-16-149-0400
400	1265	698	1008	465	37	199	28,0	0	103,0	212,0	222-16-199-0400
450	565	758	339	520	37	51	280,0	0	272,0	159,0	222-16-051-0450
450	835	758	609	520	37	101	84,0	0	191,0	188,0	222-16-101-0450
450	1095	758	869	520	37	150	41,0	0	149,0	217,0	222-16-150-0450
450	1355	758	1129	520	37	199	24,0	0	122,0	247,0	222-16-199-0450

\*1 = Mittenabstand / center distance

Weitere Abmessungen und Werkstoffe auf Anfrage. /

Other dimensions and materials on request.

**Typ 222 Abmessungen  
Ausführung 2**

**Type 222 Specifications**

**Model 2**

**Druckstufe  
Design**

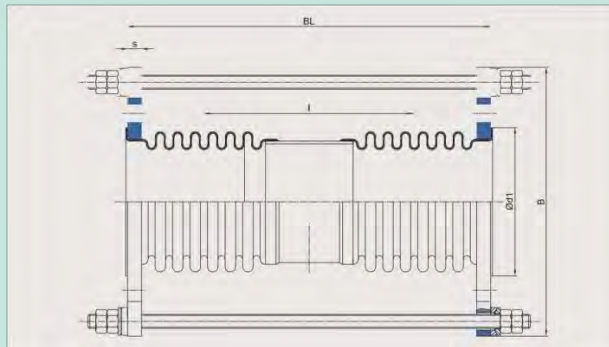

**25 barg (PN 25)  
pressure 25 barg (PN 25)**

DN	Länge Length	Größte Breite Biggest width	Balg Bellows	Flansch Flanges			Bewegungsaufnahme Movement lateral	Verstellmomentrate Friction rate			Gewicht Weight	Artikel Article
	BL mm	B mm	l* mm	Ød1	s mm	mm	2λN mm	Cλ N/mm	Cp N/mm barg	Cr N/barg		
50	320	251	214	92	22		49	16,0	0	5,0	10,8	222-25-049-0050
50	510	251	404	92	22		101	4,5	0	3,3	12,5	222-25-101-0050
50	690	251	584	92	22		150	2,2	0	2,5	14,1	222-25-150-0050
50	870	251	764	92	22		200	1,3	0	2,0	15,7	222-25-200-0050
65	335	271	223	107	22		52	22,0	0	7,4	12,5	222-25-052-0065
65	515	271	403	107	22		101	6,8	0	5,1	14,3	222-25-101-0065
65	705	271	593	107	22		149	3,2	0	3,8	16,3	222-25-149-0065
65	925	271	813	107	22		201	1,7	0	3,0	18,7	222-25-201-0065
80	350	286	216	122	22		51	41,0	0	13,0	14,4	222-25-051-0080
80	530	286	396	122	22		101	12,0	0	8,5	16,5	222-25-101-0080
80	710	286	576	122	22		150	5,4	0	6,5	18,6	222-25-150-0080
80	920	286	786	122	22		200	2,9	0	5,1	21,0	222-25-200-0080
100	470	321	327	147	27		51	42,0	0	16,0	22,2	222-25-051-0100
100	750	321	607	147	27		100	12,0	0	9,9	26,2	222-25-100-0100
100	1030	321	887	147	27		150	5,5	0	7,3	30,1	222-25-150-0100
100	1310	321	1167	147	27		201	3,2	0	5,8	34,1	222-25-201-0100
125	450	356	301	178	27		50	74,0	0	24,0	27,6	222-25-050-0125
125	710	356	561	178	27		100	21,0	0	16,0	31,9	222-25-100-0125
125	970	356	821	178	27		150	9,4	0	12,0	36,2	222-25-150-0125
125	1230	356	1081	178	27		201	5,4	0	9,1	40,5	222-25-201-0125
150	510	402	326	208	32		50	163,0	0	36,0	40,6	222-25-050-0150
150	790	402	606	208	32		100	45,0	0	24,0	47,1	222-25-100-0150
150	1060	402	876	208	32		150	22,0	0	18,0	53,2	222-25-150-0150
150	1340	402	1156	208	32		201	12,0	0	15,0	59,7	222-25-201-0150
200	570	478	400	258	32		51	188,0	0	63,0	61,5	222-25-051-0200
200	910	478	740	258	32		100	53,0	0	42,0	75,2	222-25-100-0200
200	1260	478	1090	258	32		150	24,0	0	31,0	89,1	222-25-150-0200
200	1600	478	1430	258	32		200	14,0	0	25,0	103,0	222-25-200-0200
250	485	543	309	320	32		50	157,0	0	112,0	74,9	222-25-050-0250
250	745	543	569	320	32		100	44,0	0	77,0	89,7	222-25-100-0250
250	1055	543	879	320	32		150	18,0	0	56,0	108,0	222-25-150-0250
250	1375	543	1199	320	32		201	9,6	0	44,0	126,0	222-25-201-0250
300	690	604	479	375	37		50	476,0	0	113,0	131,0	222-25-050-0300
300	1100	604	889	375	37		100	133,0	0	74,0	162,0	222-25-100-0300
300	1510	604	1299	375	37		150	62,0	0	55,0	194,0	222-25-150-0300
300	1910	604	1699	375	37		200	36,0	0	44,0	224,0	222-25-200-0300
350	570	673	356	410	42		51	204,0	0	161,0	147,0	222-25-051-0350
350	870	673	656	410	42		102	58,0	0	110,0	172,0	222-25-102-0350
350	1170	673	956	410	42		150	27,0	0	83,0	197,0	222-25-150-0350

## Typ 222 Abmessungen Ausführung 2

### Type 222 Specifications

| 350 | 1510 | 673 | 1296 | 410 | 42 | 200 | 15,0 | 0 | 66,0 | 225,0 | **222-25-200-0350** |  
\*l = Mittenabstand / center distance

Weitere Abmessungen und Werkstoffe auf Anfrage. /  
Other dimensions and materials on request.





## Lateralkompensator mit Festflanschen und Zugstangen Typ 224

### Typ 225 (mit Innenleitrohr)

Der Typ 224 ist ein mehrlagiger Lateralkompensator mit Festflanschen. Die Zugstangenverspannung ist auf die Anschlüsse aufgeschweißt.

Er ist speziell konzipiert für den Betrieb in Anlagen mit Betriebsdrücken bis 25 barg.

Dieser Kompensator lässt ausschließlich laterale Bewegungen zu.

#### Beschreibung

Neben den aufgeführten Standardbaulängen kann er speziell auf Ihre Bedürfnisse angepasst gefertigt werden. Dieser Kompensator kann auch in anderen Werkstoffen (siehe Seite 179) gefertigt werden.

#### Ausführung

Zur Realisierung größerer Kompensatorenbaulängen ist die Variante mit einem eingeschweißten Zwischenrohr (Ausführung 2) erhältlich. Bei Vakuumbetrieb auch zuzüglich innerer Zugverspannung.

#### Vorteile

- Aufnahme von Bewegungen in sämtliche laterale Richtungen
- Aufnahme großer lateraler Bewegungen mit nur einem Lateralkompensator
- Verringert die auf alle Festpunkte wirkenden Lasten, da die Zuganker, die Lasten aufnehmen, ohne die axiale Druckkraft auf die Festpunkte zu übertragen

## Lateral expansion joint with fixed flanges and tie rods

### Type 224

### Type 225 (with internal sleeve)



Type 224 is a multi-layer lateral expansion joint with fixed flanges. This expansion joint has tie rods.

It is designed specifically for operation in installations with operating pressures up to 25 barg.

This expansion joint only allows lateral movements.

#### Description

In addition to the given standard lengths, other lengths are available to meet specific requirements. This expansion joint can also be produced in other materials (see page 179).

#### Versions

For longer expansion joint lengths, a version with a welded intermediate pipe is available (version 2). For vacuum operation also additional lock nuts are available.

#### Advantages

- Suitable for movements in all lateral directions
  - For large lateral movements with only one lateral expansion joint
- Reduces loads exerted on all fixed points, since the tie rods absorb the loads without transmitting the axial compressive force to the fixed points

## Type 225 (with internal sleeve)

<b>Einsatzbeispiele</b>	Dampfanlagen, Wasser, Entwässerung etc.
<b>Standardmäßiger Aufbau</b>	Mehrlagiger Wellrohrbalg aus 1.4541 mit Festflanschen und Verspannung aus C-Stahl.
<b>Zulässige Betriebsdaten (Standard)</b>	16 barg / 120 °C gem. EJMA Höhere Drücke auf Anfrage.
<b>Zubehör</b>	Innenleitrohr, Außenschutzrohr
<b>Hinweis</b>	Bei Verwendung von Leitrohren vermindert sich der Balgquerschnitt. Bitte beachten Sie bei Ihrer Planung die Medienverträglichkeit der zu verwendenden Kompensatorenmaterialien.

<b>Application examples</b>	Steam plants, water, drainage, etc.
<b>Standard design</b>	Multi-layer corrugated tube bellows of 1.4541 with fixed flanges and tie rods of carbon steel.
<b>Permissible operating data</b>	16 barg / 120 °C acc. to EJMA Higher pressures on request.
<b>Accessories</b>	Internal sleeve, external protective sleeve
<b>Note</b>	Using internal sleeves will reduce the bellows cross-section. To be noted is that the media compatibility of the expansion joint material to be used should be taken into account in the planning phase.

**Ausführung 1 / Model 1**



**Ausführung 2 / Model 2**



**Typ 224 Abmessungen  
Ausführung 1**

**Versions  
Type 224  
Model 1**

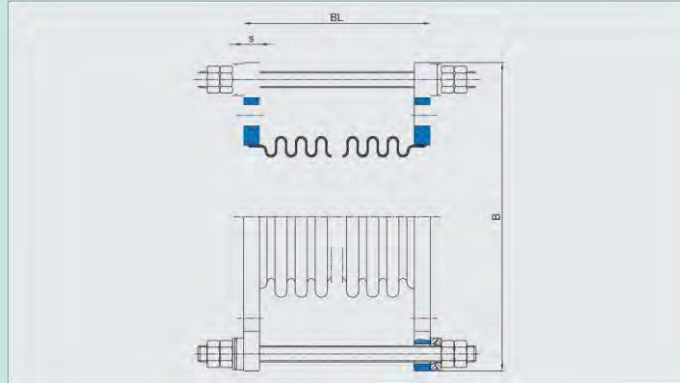

**Ausführungsvarianten /  
Specifications**

**Druckstufe 6 barg (PN 6)  
Design pressure 6 barg (PN 6)**

DN	Länge Length	Größte Breite Biggest width	Flansch Flanges	Bewegungsaufnahme Movement lateral	Verstellmomentrate Friction rate			Gewicht Weight	Artikel Article
	BL mm				B mm	s mm	2λN mm		
50	150	226	17	17	44	0	9,1	5,6	224-06-017-0050
50	245	226	17	43	12	0	6,2	6,4	224-06-043-0050
65	140	246	17	12	79	0	16,0	6,4	224-06-012-0065
65	205	246	17	32	28	0	12,0	7,1	224-06-032-0065
80	125	276	17	6	285	0	30,0	8,4	224-06-006-0080
80	170	276	17	15	60	0	24,0	8,8	224-06-015-0080
80	235	276	17	33	38	0	18,0	9,9	224-06-033-0080
100	135	296	17	6	280	0	46,0	9,2	224-06-006-0100
100	175	296	17	16	129	0	38,0	10,0	224-06-016-0100
100	255	296	17	39	60	0	28,0	12,2	224-06-039-0100
125	145	326	22	5	470	0	63,0	13,2	224-06-005-0125
125	195	326	22	16	144	0	50,0	14,0	224-06-016-0125
125	295	326	22	40	72	0	35,0	17,0	224-06-040-0125

Weitere Abmessungen und Werkstoffe auf Anfrage./  
Other dimensions and materials on request.



150	160	351	22	5	644	0	84,0	14,6	224-06-005-0150
150	240	351	22	21	209	0	61,0	16,9	224-06-021-0150
150	344	351	22	50	92	0	44,0	21,2	224-06-050-0150
200	165	406	22	7	557	0	134,0	18,4	224-06-007-0200
200	250	406	22	22	232	0	96,0	22,1	224-06-022-0200
200	305	406	22	39	195	0	81,0	26,8	224-06-039-0200
250	165	461	22	5	1230	0	201,0	21,9	224-06-005-0250
250	250	461	22	19	425	0	146,0	26,1	224-06-019-0250
250	350	461	22	33	203	0	108,0	31,3	224-06-033-0250
300	190	526	27	5	1860	0	252,0	36,3	224-06-005-0300
300	225	526	27	12	611	0	220,0	38,0	224-06-012-0300
300	285	526	27	24	461	0	183,0	44,9	224-06-024-0300
350	180	576	27	5	2560	0	313,0	44,9	224-06-005-0350
350	225	576	27	11	697	0	264,0	47,8	224-06-011-0350
350	320	576	27	25	416	0	196,0	54,4	224-06-025-0350
400	225	642	27	7	1730	0	406,0	53,2	224-06-007-0400
400	290	642	27	17	602	0	335,0	57,8	224-06-017-0400
400	435	642	27	38	369	0	234,0	74,9	224-06-038-0400
450	210	697	27	5	4840	0	542,0	61,7	224-06-005-0450
450	265	697	27	12	1200	0	456,0	64,8	224-06-012-0450
450	390	697	27	31	537	0	327,0	84,2	224-06-031-0450
500	240	747	32	5	5130	0	605,0	76,1	224-06-005-0500
500	340	747	32	16	885	0	455,0	80,1	224-06-016-0500
500	440	747	32	33	595	0	363,0	102,0	224-06-033-0500

**Typ 224 Abmessungen  
Ausführung 1**

**Type 224 Specifications**

**Model 1**

**Druckstufe 10 barg (PN 10)  
Design pressure 10 barg (PN 10)**

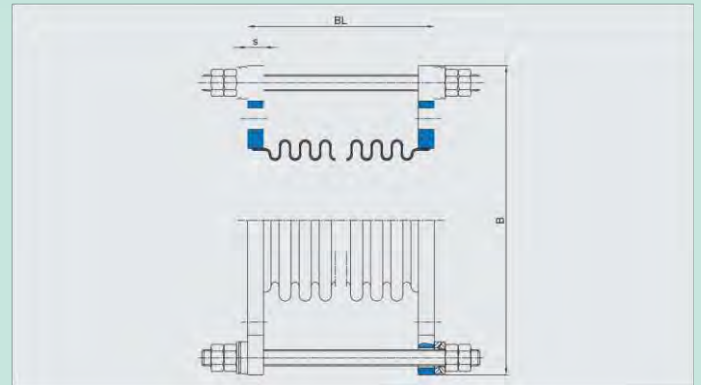

DN	Länge	Größte Breite		Flansch		Bewegungsaufnahme		Verstellmomentrate			Gewicht	Artikel
	Length	Biggest width		Flanges		Movement lateral		Friction rate				
	BL	B		s		2ΔN		CΔ	Cp	Cr	kg	
	mm	mm		mm		mm		N/mm	N/mm barg	N/barg		
50	130	251		18		10		85	0	11,0	7,5	224-10-010-0050
50	200	251		18		25		26	0	7,3	8,1	224-10-025-0050
65	140	271		22		9		125	0	16,0	9,9	224-10-009-0065
65	205	271		22		21		40	0	12,0	10,5	224-10-021-0065
80	135	286		22		5		316	0	28,0	11,1	224-10-005-0080
80	215	286		22		25		120	0	19,0	12,4	224-10-025-0080
80	245	286		22		26		62	0	17,0	12,6	224-10-026-0080
100	140	306		22		6		454	0	44,0	12,3	224-10-006-0100
100	175	306		22		12		168	0	37,0	13,0	224-10-012-0100
100	270	306		22		30		92	0	25,0	14,7	224-10-030-0100
125	135	336		22		5		510	0	66,0	14,6	224-10-005-0125

Weitere Abmessungen und Werkstoffe auf Anfrage. /  
Other dimensions and materials on request.

**Typ 224 Abmessungen**  
**Ausführung 1**

125	175	336	22	11	255	0	53,0	15,2	224-10-011-0125
125	255	336	22	25	143	0	39,0	17,5	224-10-025-0125
150	150	371	27	3	1790	0	87,0	20,9	224-10-003-0150
150	230	371	27	15	264	0	63,0	23,0	224-10-015-0150
150	330	371	27	31	155	0	45,0	25,0	224-10-031-0150
200	170	426	27	4	2590	0	130,0	27,1	224-10-004-0200
200	215	426	27	12	483	0	110,0	28,7	224-10-012-0200
200	285	426	27	24	304	0	85,0	33,1	224-10-024-0200
250	170	497	27	3	4440	0	231,0	33,3	224-10-003-0250
250	215	497	27	10	885	0	197,0	35,5	224-10-010-0250
250	300	497	27	23	464	0	147,0	42,6	224-10-023-0250
300	165	531	27	3	6070	0	282,0	39,5	224-10-003-0300
300	255	531	27	14	777	0	200,0	44,5	224-10-014-0300
300	330	531	27	26	561	0	161,0	55,3	224-10-026-0300
350	165	607	27	3	8350	0	392,0	54,0	224-10-003-0350
350	220	607	27	10	1530	0	322,0	57,7	224-10-010-0350
350	300	607	27	19	737	0	245,0	64,9	224-10-019-0350
400	190	683	32	3	10600	0	522,0	77,8	224-10-003-0400
400	305	683	32	15	1040	0	366,0	84,1	224-10-015-0400
400	375	683	32	27	834	0	306,0	97,0	224-10-027-0400

**Typ 224 Abmessungen**  
**Ausführung 1**

**Type 224 Specifications**

450	230	733	32	6	4970	0	566,0	86,8	224-10-006-0450
450	295	733	32	14	1880	0	473,0	95,8	224-10-014-0450
450	430	733	32	32	853	0	344,0	120,0	224-10-032-0450
500	210	788	37	2	29300	0	745,0	106,0	224-10-002-0500
500	290	788	37	10	3500	0	588,0	116,0	224-10-010-0500
500	410	788	37	25	1180	0	443,0	130,0	224-10-025-0500

**Typ 224 Abmessungen  
Ausführung 1**

**Type 224 Specifications  
Model 1**

**Druckstufe 16 barg (PN 16)  
Design pressure 16 barg (PN 16)**

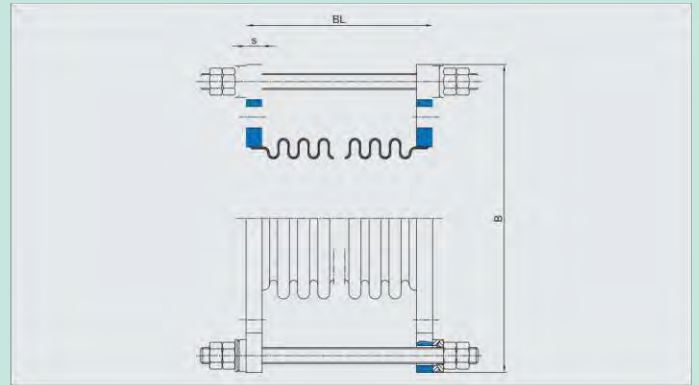

DN	Länge Length		Größte Breite Biggest width		Flansch Flanges		Bewegungsaufnahme Movement		Verstellmomentrate Friction rate			Gewicht Weight	Artikel Article
	BL mm	B mm	s mm	2ΔN mm	CΔ N/mm	Cp N/mm barg	Cr N/barg	kg					
50	130	251	18	9	85	0	11,0	7,5	224-16-009-0050				
50	210	251	18	25	39	0	6,8	8,3	224-16-025-0050				
65	140	271	22	8	125	0	16,0	9,9	224-16-008-0065				
65	215	271	22	24	61	0	12,0	11,1	224-16-024-0065				
80	135	286	22	5	316	0	28,0	11,1	224-16-005-0080				
80	215	286	22	19	120	0	19,0	12,4	224-16-019-0080				
100	140	306	22	6	454	0	44,0	12,3	224-16-006-0100				
100	190	306	22	13	233	0	34,0	13,5	224-16-013-0100				
125	125	336	22	2	1980	0	69,0	14,6	224-16-002-0125				
125	165	336	22	9	493	0	57,0	15,7	224-16-009-0125				
125	200	336	22	14	319	0	48,0	17,3	224-16-014-0125				
150	155	371	27	3	2890	0	86,0	21,0	224-16-003-0150				
150	185	371	27	8	722	0	76,0	21,8	224-16-008-0150				
150	250	371	27	17	362	0	58,0	25,0	224-16-017-0150				
200	155	442	27	3	5180	0	163,0	29,1	224-16-003-0200				
200	225	442	27	11	676	0	123,0	31,2	224-16-011-0200				
200	315	442	27	24	440	0	92,0	37,9	224-16-024-0200				
250	195	507	27	4	3490	0	206,0	38,5	224-16-004-0250				
250	235	507	27	10	1230	0	180,0	42,2	224-16-010-0250				
250	335	507	27	22	629	0	133,0	51,0	224-16-022-0250				
300	175	562	32	2	16900	0	311,0	53,7	224-16-002-0300				
300	230	562	32	8	2670	0	256,0	58,3	224-16-008-0300				
300	320	562	32	18	910	0	194,0	69,0	224-16-018-0300				
350	185	638	32	3	11100	0	400,0	72,7	224-16-003-0350				
350	220	638	32	7	3660	0	356,0	76,9	224-16-007-0350				
350	320	638	32	17	1130	0	266,0	89,2	224-16-017-0350				
400	225	698	37	4	10200	0	459,0	105,0	224-16-004-0400				
400	290	698	37	10	2570	0	378,0	109,0	224-16-010-0400				
400	320	698	37	15	1610	0	351,0	113,0	224-16-015-0400				
450	225	758	37	3	15600	0	572,0	119,0	224-16-003-0450				
450	290	758	37	9	3740	0	471,0	123,0	224-16-009-0450				
450	320	758	37	15	2220	0	439,0	128,0	224-16-015-0450				

Weitere Abmessungen und Werkstoffe auf Anfrage. /  
Other dimensions and materials on request.

**Typ 224 Abmessungen  
Ausführung 1**

**Type 224 Specifications  
Model 1**

**Druckstufe 25 barg (PN 25)  
Design pressure 25 barg (PN 25)**

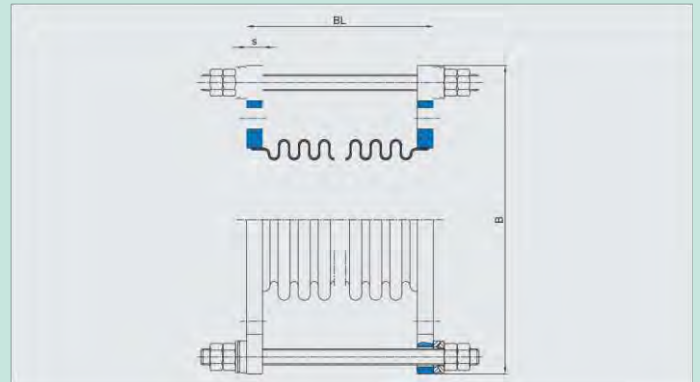

DN	Länge Length		Größte Breite Biggest width		Flansch Flanges		Bewegungsaufnahme Movement lateral		Verstellmomentrate Friction rate			Gewicht Weight kg	Artikel Article
	BL mm		B mm		s mm		2λN mm	Cλ N/mm	Cp N/mm barg	Cr N/barg			
50	130		251		22		6	121	0	11,0	8,8	224-25-006-0050	
50	185		251		22		16	75	0	7,6	9,3	224-25-016-0050	
65	135		271		22		6	195	0	16,0	9,9	224-25-006-0065	
65	230		271		22		21	82	0	9,9	11,3	224-25-021-0065	
80	140		286		22		5	442	0	27,0	11,3	224-25-005-0080	
80	190		286		22		12	213	0	21,0	12,4	224-25-012-0080	
100	140		321		27		4	1180	0	43,0	17,1	224-25-004-0100	
100	200		321		27		10	329	0	32,0	17,7	224-25-010-0100	

## Typ 224 Abmessungen Ausführung 1

125	165	356	27	5	928	0	56,0	21,4	224-25-005-0125
125	210	356	27	12	488	0	46,0	23,5	224-25-012-0125
150	175	402	32	3	3800	0	91,0	29,9	224-25-003-0150
150	245	402	32	12	621	0	69,0	32,2	224-25-012-0150
200	170	478	32	3	7580	0	167,0	41,4	224-25-003-0200
200	225	478	32	9	1180	0	138,0	42,7	224-25-009-0200
250	175	543	32	2	14700	0	247,0	54,6	224-25-002-0250
250	225	543	32	7	2620	0	207,0	59,1	224-25-007-0250
250	295	543	32	13	1270	0	169,0	63,8	224-25-013-0250
300	200	604	37	3	13100	0	311,0	80,6	224-25-003-0300
300	255	604	37	7	3100	0	260,0	83,4	224-25-007-0300
300	275	604	37	11	2090	0	251,0	88,4	224-25-011-0300
350	210	673	42	2	18300	0	359,0	116,0	224-25-002-0350
350	265	673	42	6	4320	0	301,0	117,0	224-25-006-0350
350	290	673	42	10	2700	0	287,0	123,0	224-25-010-0350

Weitere Abmessungen und Werkstoffe auf Anfrage.  
/ Other dimensions and materials on request.

**Typ 224 Abmessungen**  
**Ausführung 2**

**Type 224 Specifications**  
**Model 2**

**Druckstufe 6 barg (PN 6)**  
**Design pressure 6 barg (PN 6)**

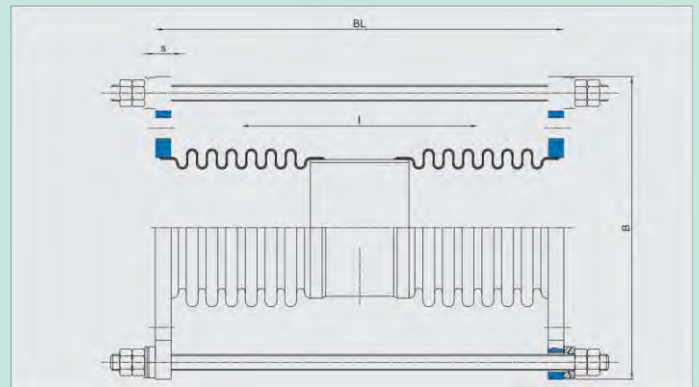

DN	Länge	Größte Breite	Balg	Flansch	Bewegungsaufnahme	Verstellmomentrate			Gewicht	Artikel	
	Length	Biggest width	Bellow	Flanges		Movement	Friction rate				
	BL	B	I*	s	lateral	2ΔN	CΔ	Cp	Cr	kg	
	mm	mm	mm	mm		mm	N/mm	N/mm barg	N/barg		
50	285	226	166	17	63	63	4,0	0	5,5	6,6	224-06-063-0050
50	365	226	246	17	101	101	1,9	0	4,5	7,1	224-06-101-0050
50	465	226	346	17	151	151	1,0	0	3,6	7,7	224-06-151-0050
50	565	226	446	17	201	201	0,6	0	3,0	8,5	224-06-201-0050
65	300	246	172	17	60	60	6,4	0	8,2	7,7	224-06-060-0065
65	390	246	262	17	98	98	2,9	0	6,5	8,4	224-06-098-0065
65	500	246	372	17	148	148	1,5	0	5,3	9,4	224-06-148-0065
65	610	246	482	17	199	199	0,9	0	4,5	10,4	224-06-199-0065
80	280	276	163	17	65	65	15,0	0	16,0	10,2	224-06-065-0080
80	360	276	243	17	105	105	6,7	0	13,0	11,2	224-06-105-0080
80	450	276	333	17	151	151	3,5	0	11,0	12,0	224-06-151-0080
80	550	276	433	17	203	203	2,1	0	8,5	13,0	224-06-203-0080
100	265	296	156	17	58	58	33,0	0	26,0	12,3	224-06-058-0100
100	355	296	246	17	100	100	13,0	0	21,0	13,6	224-06-100-0100
100	465	296	356	17	153	153	5,9	0	16,0	14,9	224-06-153-0100
100	565	296	456	17	203	203	3,5	0	14,0	16,2	224-06-203-0100
125	320	326	203	22	51	51	28,0	0	33,0	16,7	224-06-051-0125
125	480	326	363	22	101	101	8,3	0	23,0	19,4	224-06-101-0125
125	640	326	523	22	152	152	4,0	0	18,0	21,9	224-06-152-0125



**Typ 224 Abmessungen**  
**Ausführung 2**  
**Type 224 Specifications**

125	820	326	703	22	202	2,2	0	15,0	24,9	224-06-202-0125
150	290	351	168	22	50	49,0	0	52,0	18,4	224-06-050-0150
150	430	351	308	22	102	14,0	0	37,0	21,4	224-06-102-0150
150	560	351	438	22	153	6,6	0	29,0	24,1	224-06-153-0150
150	690	351	568	22	200	3,9	0	24,0	26,9	224-06-200-0150
200	335	406	196	22	52	84,0	0	75,0	26,4	224-06-052-0200
200	485	406	346	22	101	26,0	0	54,0	32,0	224-06-101-0200
200	635	406	496	22	153	13,0	0	42,0	37,3	224-06-153-0200
200	775	406	636	22	202	7,4	0	35,0	42,3	224-06-202-0200
250	365	461	226	22	51	107,0	0	106,0	33,9	224-06-051-0250
250	545	461	406	22	101	32,0	0	74,0	41,9	224-06-101-0250
250	715	461	576	22	150	16,0	0	58,0	49,4	224-06-150-0250
250	895	461	756	22	201	8,9	0	47,0	57,4	224-06-201-0250
300	385	526	235	27	52	120,0	0	141,0	49,1	224-06-052-0300
300	565	526	415	27	100	37,0	0	100,0	60,0	224-06-100-0300
300	745	526	595	27	150	18,0	0	78,0	70,8	224-06-150-0300
300	935	526	785	27	200	11,0	0	63,0	82,3	224-06-200-0300
350	405	576	256	27	50	141,0	0	160,0	59,0	224-06-050-0350
350	615	576	466	27	101	41,0	0	110,0	71,6	224-06-101-0350
350	815	576	666	27	150	20,0	0	85,0	83,4	224-06-150-0350
350	1045	576	896	27	200	11,0	0	67,0	97,1	224-06-200-0350
400	405	642	246	27	50	229,0	0	252,0	70,1	224-06-050-0400
400	605	642	446	27	101	66,0	0	177,0	84,1	224-06-101-0400
400	795	642	636	27	150	32,0	0	138,0	97,4	224-06-150-0400
400	995	642	836	27	201	18,0	0	112,0	112,0	224-06-201-0400
450	440	697	243	27	51	228,0	0	292,0	85,7	224-06-051-0450
450	630	697	433	27	102	71,0	0	212,0	101,0	224-06-102-0450
450	800	697	603	27	150	36,0	0	171,0	114,0	224-06-150-0450

## Typ 224 Abmessungen Ausführung 2

### Type 224 Specifications

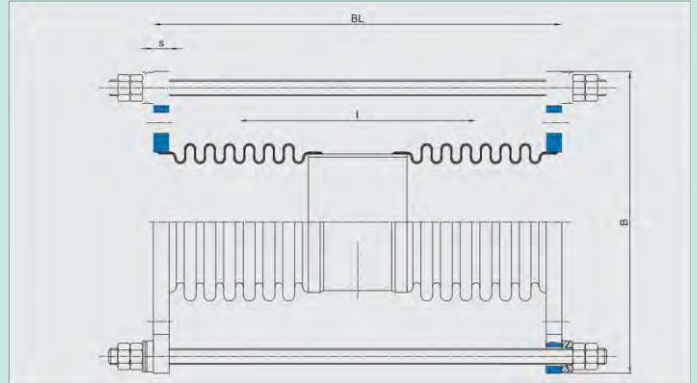

450	980	697	783	27	201	21,0	0	141,0	128,0	224-06-201-0450
500	505	747	336	32	50	321,0	0	318,0	109,0	224-06-050-0500
500	795	747	626	32	101	87,0	0	211,0	133,0	224-06-101-0500
500	1065	747	896	32	150	42,0	0	161,0	157,0	224-06-150-0500
500	1345	747	1176	32	200	24,0	0	129,0	180,0	224-06-200-0500

\*l = Mittenabstand / center distance

Weitere Abmessungen und Werkstoffe auf Anfrage. /  
Other dimensions and materials on request.

## Model 2

### Druckstufe 10 barg (PN 10)

#### Design pressure 10 barg (PN 10)

DN	Länge Length	Größte Breite Biggest width	Balg Bellow	Flansch Flanges	Bewegungsaufnahme Movement lateral	Verstellmomentrate Friction rate			Gewicht Weight	Artikel Article
	BL mm	B mm	l* mm	s mm	2AN mm	CA N/mm	Cp N/mm barg	Cr N/barg	kg	
50	280	251	162	18	64	7,7	0	5,6	8,5	224-10-064-0050
50	360	251	242	18	103	3,6	0	4,5	9,2	224-10-103-0050
50	460	251	342	18	153	1,8	0	3,6	9,8	224-10-153-0050
50	550	251	432	18	200	1,2	0	3,1	10,6	224-10-200-0050
65	320	271	178	22	56	9,6	0	7,8	11,3	224-10-056-0065
65	430	271	288	22	99	3,9	0	6,0	12,3	224-10-099-0065

**Typ 224 Abmessungen**  
**Ausführung 2**  
**Type 224 Specifications**

65	550	271	408	22	149	2,0	0	4,8	13,4	224-10-149-0065
65	670	271	528	22	200	1,2	0	4,0	14,4	224-10-200-0065
80	300	286	168	22	62	26,0	0	15,0	13,3	224-10-062-0080
80	390	286	258	22	103	11,0	0	12,0	14,1	224-10-103-0080
80	490	286	358	22	151	5,4	0	9,2	15,2	224-10-151-0080
80	600	286	468	22	205	3,1	0	7,6	16,1	224-10-205-0080
100	285	306	166	22	49	29,0	0	25,0	15,6	224-10-049-0100
100	425	306	306	22	101	8,0	0	18,0	17,4	224-10-101-0100
100	555	306	436	22	151	3,9	0	14,0	19,0	224-10-151-0100
100	675	306	556	22	198	2,4	0	12,0	20,6	224-10-198-0100
125	335	336	220	22	51	24,0	0	32,0	18,3	224-10-051-0125
125	505	336	390	22	98	7,2	0	22,0	21,2	224-10-098-0125
125	675	336	560	22	146	3,5	0	17,0	24,0	224-10-146-0125
125	885	336	770	22	201	1,8	0	14,0	27,4	224-10-201-0125
150	335	371	201	27	51	61,0	0	46,0	26,1	224-10-051-0150
150	495	371	361	27	101	18,0	0	33,0	29,6	224-10-101-0150
150	655	371	521	27	152	8,3	0	26,0	32,9	224-10-152-0150
150	835	371	701	27	201	4,6	0	20,0	36,7	224-10-201-0150
200	340	426	203	27	52	102,0	0	75,0	36,3	224-10-052-0200
200	500	426	363	27	101	31,0	0	53,0	42,2	224-10-101-0200
200	660	426	523	27	153	15,0	0	41,0	47,9	224-10-153-0200
200	830	426	693	27	200	8,0	0	33,0	54,1	224-10-200-0200
250	405	497	256	27	52	83,0	0	116,0	45,9	224-10-052-0250
250	605	497	456	27	101	25,0	0	81,0	55,2	224-10-101-0250
250	815	497	666	27	154	12,0	0	62,0	65,1	224-10-154-0250
250	1005	497	856	27	202	6,9	0	51,0	73,8	224-10-202-0250
300	445	531	300	27	51	152,0	0	122,0	58,8	224-10-051-0300
300	685	531	540	27	100	45,0	0	83,0	73,3	224-10-100-0300

**Typ 224 Abmessungen**  
**Ausführung 2**

**Type 224 Specifications**

300	955	531	810	27	150	20,0	0	61,0	89,4	224-10-150-0300
300	1245	531	1100	27	201	11,0	0	47,0	107,0	224-10-201-0300
350	435	607	286	27	51	112,0	0	180,0	68,6	224-10-051-0350
350	675	607	526	27	102	32,0	0	122,0	83,4	224-10-102-0350
350	905	607	756	27	152	16,0	0	93,0	97,7	224-10-152-0350
350	1155	607	1006	27	200	8,5	0	74,0	114,0	224-10-200-0350
400	430	683	263	32	51	198,0	0	276,0	94,4	224-10-051-0400
400	640	683	473	32	101	58,0	0	195,0	110,0	224-10-101-0400
400	850	683	683	32	150	28,0	0	151,0	125,0	224-10-150-0400
400	1110	683	943	32	201	14,0	0	118,0	144,0	224-10-201-0400
450	490	733	298	32	50	363,0	0	306,0	115,0	224-10-050-0450
450	730	733	538	32	100	108,0	0	215,0	141,0	224-10-100-0450
450	970	733	778	32	151	51,0	0	166,0	167,0	224-10-151-0450
450	1200	733	1008	32	201	30,0	0	136,0	191,0	224-10-201-0450
500	535	788	356	37	50	284,0	0	350,0	140,0	224-10-050-0500
500	835	788	656	37	100	79,0	0	235,0	176,0	224-10-100-0500
500	1165	788	986	37	150	34,0	0	173,0	215,0	224-10-150-0500
500	1515	788	1336	37	200	19,0	0	135,0	257,0	224-10-200-0500

\*l = Mittenabstand / center distance

Weitere Abmessungen und Werkstoffe auf Anfrage. /  
Other dimensions and materials on request.

**Typ 224 Abmessungen  
Ausführung 2**

**Type 224 Specifications**

**Model 2**

**Druckstufe  
Design**

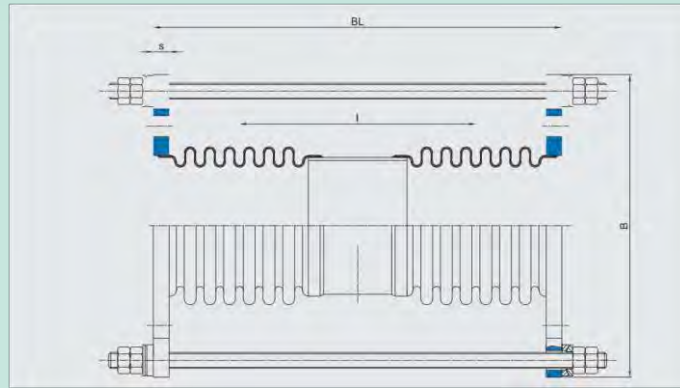

**16 barg (PN 16)  
pressure 16 barg (PN 16)**

DN	Länge	Größte Breite	Balg	Flansch	Bewegungsaufnahme	Verstellmomentrate			Gewicht	Artikel
	Length	Biggest width	Bellow	Flanges	Movement lateral	Friction rate				
	BL	B	l*	s	2ΔN	CΔ	Cp	Cr	kg	
	mm	mm	mm	mm	mm	N/mm	N/mm barg	N/barg		
50	305	251	214	18	50	16,0	0	5,1	9,2	224-16-050-0050
50	485	251	394	18	100	4,7	0	3,4	10,6	224-16-100-0050
50	665	251	574	18	150	2,2	0	2,6	11,9	224-16-150-0050
50	845	251	754	18	201	1,3	0	2,1	13,0	224-16-201-0050
65	320	271	213	22	50	25,0	0	7,7	12,1	224-16-050-0065
65	500	271	393	22	100	7,2	0	5,2	13,7	224-16-100-0065
65	680	271	573	22	151	3,4	0	3,9	15,2	224-16-151-0065
65	850	271	743	22	200	2,1	0	3,2	16,5	224-16-200-0065
80	320	286	208	22	50	45,0	0	14,0	13,9	224-16-050-0080
80	500	286	388	22	101	13,0	0	9,0	15,7	224-16-101-0080
80	670	286	558	22	151	5,8	0	6,9	17,5	224-16-151-0080
80	840	286	728	22	201	3,4	0	5,6	19,0	224-16-201-0080
100	425	306	315	22	50	45,0	0	17,0	17,2	224-16-050-0100
100	705	306	595	22	101	13,0	0	11,0	20,7	224-16-101-0100
100	975	306	865	22	150	5,7	0	7,7	24,2	224-16-150-0100
100	1245	306	1135	22	200	3,3	0	6,1	27,8	224-16-200-0100
125	415	336	300	22	51	74,0	0	25,0	21,9	224-16-051-0125
125	665	336	550	22	100	22,0	0	17,0	26,1	224-16-100-0125
125	915	336	800	22	150	9,9	0	13,0	30,0	224-16-150-0125

## Typ 224 Abmessungen

### Ausführung 2

### Type 224 Specifications

125	1165	336	1050	22	200	5,7	0	9,6	34,2	224-16-200-0125
150	355	371	211	27	50	73,0	0	44,0	26,7	224-16-050-0150
150	525	371	381	27	100	21,0	0	31,0	30,1	224-16-100-0150
150	695	371	551	27	150	9,5	0	24,0	33,8	224-16-150-0150
150	855	371	711	27	199	5,6	0	20,0	37,3	224-16-199-0150
200	370	442	228	27	51	133,0	0	81,0	37,9	224-16-051-0200
200	550	442	408	27	101	40,0	0	57,0	44,6	224-16-101-0200
200	730	442	588	27	152	19,0	0	44,0	51,4	224-16-152-0200
200	940	442	798	27	201	9,9	0	35,0	59,5	224-16-201-0200
250	445	507	300	27	51	165,0	0	104,0	56,9	224-16-051-0250
250	695	507	550	27	101	47,0	0	70,0	69,3	224-16-101-0250
250	955	507	810	27	150	22,0	0	52,0	81,9	224-16-150-0250
250	1245	507	1100	27	200	12,0	0	41,0	96,0	224-16-200-0250
300	465	562	310	32	50	142,0	0	141,0	73,6	224-16-050-0300
300	725	562	570	32	99	40,0	0	95,0	89,8	224-16-099-0300
300	1045	562	890	32	150	16,0	0	68,0	110,0	224-16-150-0300
300	1355	562	1200	32	200	8,6	0	53,0	130,0	224-16-200-0300
350	485	638	320	32	50	142,0	0	187,0	98,1	224-16-050-0350
350	755	638	590	32	101	41,0	0	127,0	120,0	224-16-101-0350
350	1015	638	850	32	152	20,0	0	97,0	141,0	224-16-152-0350
350	1275	638	1110	32	200	12,0	0	78,0	161,0	224-16-200-0350
400	560	698	373	37	51	369,0	0	213,0	145,0	224-16-051-0400
400	780	698	548	37	99	97,0	0	160,0	165,0	224-16-099-0400
400	1010	698	778	37	149	48,0	0	126,0	188,0	224-16-149-0400
400	1240	698	1008	37	199	28,0	0	104,0	212,0	224-16-199-0400
450	540	758	338	37	51	280,0	0	281,0	150,0	224-16-051-0450
450	810	758	608	37	100	84,0	0	196,0	179,0	224-16-100-0450

## Typ 224 Abmessungen Ausführung 2

### Type 224 Specifications

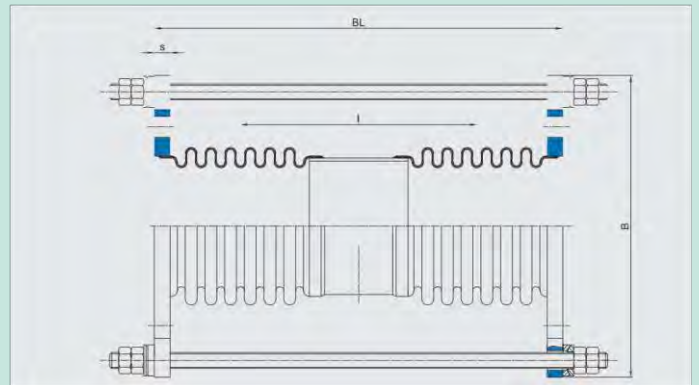

450	1070	758	868	37	149	41,0	0	152,0	209,0	224-16-149-0450
450	1330	758	1128	37	199	24,0	0	124,0	238,0	224-16-199-0450

\*I = Mittenabstand / center distance

Weitere Abmessungen und Werkstoffe auf Anfrage. /  
Other dimensions and materials on request.

## Model 2

### Druckstufe 25 barg (PN 25)

#### Design pressure 25 barg (PN 25)

DN	Länge Length	Größte Breite Biggest width	Balg Bellow	Flansch Flanges	Bewegungsaufnahme Movement lateral	Verstellmomentrate Friction rate			Gewicht Weight kg	Artikel Article
	BL mm	B mm	I* mm	s mm	2ΔN mm	CΔ N/mm	Cp N/mm barg	Cr N/barg		
50	315	251	215	22	49	16,0	0	5,0	10,8	224-25-049-0050
50	505	251	405	22	101	4,4	0	3,3	12,5	224-25-101-0050
50	685	251	585	22	150	2,2	0	2,5	14,1	224-25-150-0050
50	865	251	765	22	200	1,3	0	2,0	15,7	224-25-200-0050
65	330	271	223	22	51	22,0	0	7,5	12,5	224-25-051-0065
65	510	271	403	22	101	6,8	0	5,1	14,3	224-25-101-0065
65	700	271	593	22	149	3,2	0	3,8	16,3	224-25-149-0065
65	920	271	813	22	201	1,7	0	3,0	18,7	224-25-201-0065

**Typ 224 Abmessungen  
Ausführung 2**

**Type 224 Specifications**

80	330	286	218	22	51	41,0	0	13,0	14,2	224-25-051-0080
80	510	286	398	22	102	12,0	0	8,9	16,3	224-25-102-0080
80	690	286	578	22	150	5,4	0	6,7	18,4	224-25-150-0080
80	900	286	788	22	201	2,9	0	5,2	20,8	224-25-201-0080
100	445	321	325	27	50	43,0	0	16,0	21,8	224-25-050-0100
100	725	321	605	27	100	12,0	0	11,0	25,6	224-25-100-0100
100	1005	321	885	27	150	5,5	0	7,5	29,7	224-25-150-0100
100	1285	321	1165	27	200	3,2	0	6,0	33,5	224-25-200-0100
125	425	356	300	27	50	74,0	0	25,0	27,4	224-25-050-0125
125	685	356	560	27	100	21,0	0	16,0	31,7	224-25-100-0125
125	945	356	820	27	150	9,4	0	12,0	36,0	224-25-150-0125
125	1205	356	1080	27	201	5,4	0	9,4	40,3	224-25-201-0125
150	485	402	326	32	50	163,0	0	37,0	39,0	224-25-050-0150
150	765	402	606	32	100	45,0	0	25,0	45,5	224-25-100-0150
150	1035	402	876	32	150	22,0	0	19,0	51,8	224-25-150-0150
150	1315	402	1156	32	201	12,0	0	15,0	58,3	224-25-201-0150
200	545	478	400	32	51	187,0	0	65,0	58,9	224-25-051-0200
200	885	478	740	32	100	53,0	0	42,0	72,6	224-25-100-0200
200	1235	478	1090	32	150	24,0	0	31,0	86,5	224-25-150-0200
200	1575	478	1430	32	200	14,0	0	25,0	101,0	224-25-200-0200
250	465	543	310	32	50	154,0	0	115,0	71,8	224-25-050-0250
250	725	543	570	32	100	44,0	0	78,0	86,6	224-25-100-0250
250	1035	543	880	32	150	18,0	0	57,0	105,0	224-25-150-0250
250	1355	543	1200	32	201	9,6	0	44,0	123,0	224-25-201-0250
300	660	604	478	37	50	477,0	0	117,0	125,0	224-25-050-0300
300	1070	604	888	37	100	133,0	0	75,0	157,0	224-25-100-0300
300	1480	604	1298	37	150	62,0	0	56,0	188,0	224-25-150-0300



## Typ 224 Abmessungen Ausführung 2

### Type 224 Specifications

300	1880	604	1698	37	200	36,0	0	44,0	218,0	224-25-200-0300
350	550	673	358	42	50	202,0	0	165,0	141,0	224-25-050-0350
350	850	673	658	42	100	58,0	0	112,0	166,0	224-25-100-0350
350	1150	673	958	42	150	27,0	0	85,0	191,0	224-25-150-0350
350	1490	673	1298	42	199	15,0	0	66,0	220,0	224-25-199-0350

\*l = Mittenabstand / center distance

Weitere Abmessungen und Werkstoffe auf Anfrage. /  
Other dimensions and materials on request.

## Fernwärmekompensator

### Typ 228 (One Step)

### Typ 229 (Fernheizkompensator) District heating expansion joint

Fernwärmekompensatoren dienen ausschließlich zur Aufnahme großer axialer Dehnung aus dem Rohrleitungssystem. Sie werden in der Regel vorgespannt geliefert und sind wartungsfrei.

Fernwärmekompensatoren sind neben der Standardausstattung (Balg und Anschlüsse) mit einem Außenschutzmantel ausgerüstet. Dadurch sind sie auch für den Erdbau geeignet.

Optional können sie mit einem Innenleitrohr geliefert werden.

Die Kompensatoren werden mit Rohrenden geliefert und sind durch die schlanke Konstruktion für gedämmte Rohrleitungssysteme geeignet.

#### Ausführung

Andere Materialien, Nennweiten und Ausführungen (z. B. Flanschanschluss) sind auf Anfrage möglich.

#### Besonderheiten

- Typ 228 wird nach dem Erreichen der Betriebstemperatur entlang des Mantels fixiert
- Typ 229 ist standardmäßig mit einer Führungseinrichtung gegen Torsion ausgestattet

## Fernwärmekompensator

### Typ 228 (One Step)

### Type 228 (One step) Type 229 (District heating expansion joint)



District heating expansion joints only serve for absorbing high axial expansion from the pipe system. These are normally supplied prestressed and are maintenance-free.

In addition to the standard components (bellows and connections), district heating expansion joints are provided with an outer protection shroud, making them also suitable for buried installation.

They can also be supplied with an optional internal sleeve.

The expansion joints are supplied with pipe ends and due to their slim design are suitable for insulated pipe systems.

#### Versions

Other materials, nominal diameters and designs (e.g. flange connection) are available on request.

#### Special features

### District heating expansion joint

### Type 228 (One step)

- Type 228 is fixed along the outside cover when the operating temperature is reached
- Type 229 is provided with a guide unit against torsion as standard

## Typ 229 (Fernheizkompensator)

<b>Nennweiten</b>	DN 40 bis DN 600 Nach Kundenwunsch bis zu DN 1800.
<b>Druckstufen</b>	PN 10 bis PN 40
<b>Temperaturbereich</b>	druckabhängig bis 150 °C
<b>Werkstoff Standard</b>	Balg 1.4541 oder 1.4571  Anschlüsse C-Stahl  Leitrohr und Schutzmantel C-Stahl

## Type 229 (District heating expansion joint)

<b>Nominal diameter</b>	DN 40 to DN 600 According to customer requiremen up to DN 1800.
<b>Design pressure</b>	PN 10 to PN 40
<b>Temperature range</b>	dependent on pressure up to 150 °C
<b>Material standard</b>	Bellow 1.4541 or 1.4571  Connections carbon steel  Sleeve and protective cover carbon steel

### Typ 228 (DN 40 - DN 200)

### Type 228 (DN 40 - DN 200)

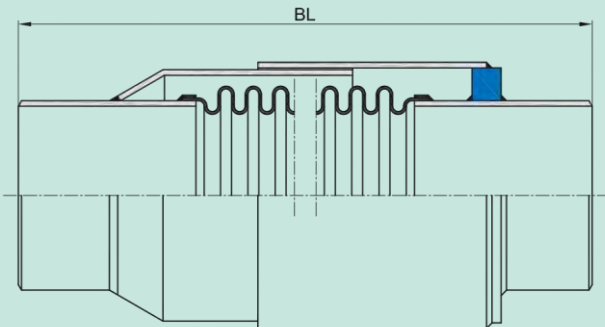

### Typ 228 (DN 40 - DN 200)

### Type 228 (DN 40 - DN 200)

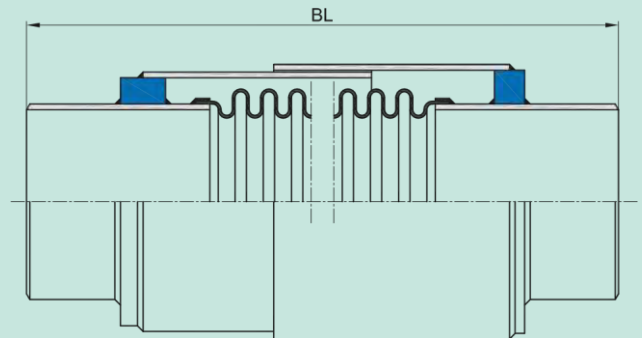

### Typ 229 Type 228

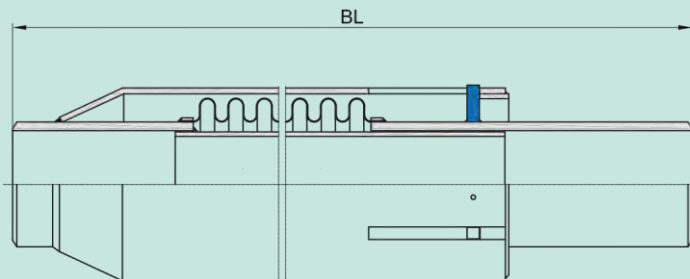

### Angularkompensator mit

Anschweißenden und einfacher  
Gelenkverspannung

### Typ 230

**Typ 231 (mit Innenleitrohr) Angular  
expansion joint with weld ends and  
single hinge construction**

### Type 230

**Typ 231 (with internal sleeve)**



Der Typ 230 ist ein mehrlagiger Angularkompensator mit Anschweißenden und ist einseitig beweglich. Die Verspannung ist auf die Anschlüsse aufgeschweißt.

Er ist speziell konzipiert für den Betrieb in Anlagen mit Betriebsdrücken bis 63 barg.

Dieser Kompensator lässt angulare Bewegungen zu.

Durch Hintereinanderschaltung zweier Kompensatoren lassen sich auch große laterale Bewegungen realisieren.

### Beschreibung

Neben den aufgeführten Standardbaulängen kann die Baulänge speziell auf Ihre Bedürfnisse angepasst gefertigt werden. Dieser Kompensator kann auch in anderen Werkstoffen (siehe Seite 179) gefertigt werden.

### Anforderungen

- Strömungsumlenkung/Umlenkung des Rohrleitungssystems erforderlich
- Höherer Platzbedarf als Axialkompensatoren
- Für ein System sind zwei oder drei Kompensatoren erforderlich

### Vorteile

- Nimmt große Bewegungen in seitlicher Richtung auf
- Verringert die auf alle Festpunkte wirkenden Lasten



Type 230 is a multi-layer angular expansion joint with weld ends. This expansion joint has a hinge construction.

It is designed specifically for operation in installations with operating pressures up to 63 barg.

This expansion joint allows angular movements.

Two expansion joints can be arranged in tandem to also allow large lateral movements.

### Description

In addition to the given standard lengths, other lengths are available to meet specific requirements. This expansion joint can also be produced in other materials (see page 179).

### Requirements

- Flow deflection/redirection of pipe system necessary
- More space required than for axial expansion joints
- Two or three expansion joints required for one system

### Advantages

- Suitable for large movements in lateral direction
- Reduces loads exerted on all fixed points

## Angularkompensator

## Angular expansion

mit Anschweißenden und einfacher Gelenkverspannung

joint with weld ends and single hinge construction

Typ 230

Type 230

Typ 231 (mit Innenleitrohr)

Type 231 (with internal sleeve)

<b>Einsatzbeispiele</b>	U- und Z-Rohrleitungssysteme
<b>Standardmäßiger Aufbau</b>	Mehrlagiger Wellrohrbalg aus 1.4541 mit Anschweißenden und Verspannung aus C-Stahl. Ab einer Anschweißendendicke von 3,5 mm ist das Anschweißende montagefertig gefast.
<b>Zulässige Betriebsdaten (Standard)</b>	16 barg / 120 °C gem. EJMA Höhere Drücke auf Anfrage.
<b>Zubehör</b>	Innenleitrohr
<b>Hinweis</b>	Bei Verwendung von Leitrohren vermindert sich der Balgquerschnitt. Die Standardausführung ist nicht vakuumfest. Bitte beachten Sie bei Ihrer Planung die Medienverträglichkeit der zu verwendenden Kompensatorenmaterialien.

<b>Application examples</b>	U and Z piping systems
<b>Standard design</b>	Multi-layer corrugated tube bellows of 1.4541 with weld ends and hinge construction of carbon steel. From a weld end thickness of 3.5 mm, these parts are bevelled ready for installation.
<b>Permissible operating data</b>	16 barg / 120 °C acc. to EJMA Higher pressures on request.
<b>Accessories</b>	Internal sleeve
<b>Note</b>	Using internal sleeves will reduce the bellows cross-section. To be noted is that the media compatibility of the expansion joint material to be used should be taken into account in the planning phase.

## Typ 230 Abmessungen Ausführung 1

## Type 230 Specifications Model 1

**Druckstufe 2,5 barg (PN 2,5)**  
**Design pressure 2.5 barg (PN 2.5)**

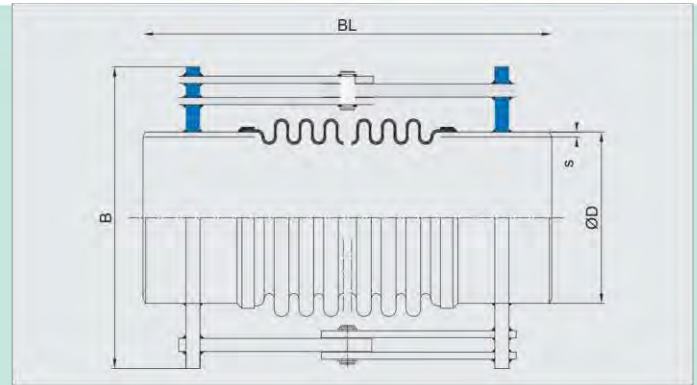

DN	Länge Length	Größte Breite Biggest width	Anschweißenden Weld ends		Bewegungsaufnahme Movement angular	Verstellmomentrate Friction rate			Gewicht Weight kg	Artikel Article
	BL mm		B mm	ØD mm		s mm	2αN °/deg.	Ca N/mm		
400	400	610	406,4	6,3	22	32	4,8	39,0	52,8	230-2,5-022-0400
400	475	610	406,4	6,3	32	19	8,0	39,0	56,3	230-2,5-032-0400
450	400	660	457,0	6,3	19	46	6,0	49,0	61,2	230-2,5-019-0450
450	475	660	457,0	6,3	29	28	10,0	49,0	65,0	230-2,5-029-0450
500	410	715	508,0	6,3	18	59	7,9,0	60,0	73,4	230-2,5-018-0500
500	510	715	508,0	6,3	28	36	15,0	60,0	77,9	230-2,5-028-0500
500	615	715	508,0	6,3	39	38	22,0	59,0	90,1	230-2,5-039-0500
600	420	830	610,0	6,0	14	151	12,0	86,0	93,5	230-2,5-014-0600
600	510	830	610,0	6,0	24	87	20,0	86,0	102,0	230-2,5-024-0600
600	630	830	610,0	6,0	32	55	32,0	86,0	107,0	230-2,5-032-0600
700	420	930	711,0	6,0	12	234	16,0	114,0	125,0	230-2,5-012-0700
700	510	930	711,0	6,0	20	129	27,0	114,0	131,0	230-2,5-020-0700
700	630	930	711,0	6,0	29	73	42,0	115,0	140,0	230-2,5-029-0700
800	400	1045	813,0	6,0	9	344	15,0	149,0	145,0	230-2,5-009-0800
800	490	1045	813,0	6,0	17	172	30,0	149,0	147,0	230-2,5-017-0800
800	640	1045	813,0	6,0	26	101	55,0	149,0	163,0	230-2,5-026-0800
900	410	1140	914,0	6,0	8	444	19,0	267,0	180,0	230-2,5-008-0900
900	500	1140	914,0	6,0	16	222	38,0	267,0	194,0	230-2,5-016-0900
900	620	1140	914,0	6,0	24	133	62,0	267,0	201,0	230-2,5-024-0900
1000	410	1255	1016,0	6,0	8	519	23,0	329,0	224,0	230-2,5-008-1000
1000	470	1255	1016,0	6,0	13	291	39,0	329,0	233,0	230-2,5-013-1000
1000	620	1255	1016,0	6,0	22	173	76,0	328,0	241,0	230-2,5-022-1000
1100	440	1360	1120,0	8,0	9	547	37,0	396,0	291,0	230-2,5-009-1100
1100	530	1360	1120,0	8,0	15	360	65,0	394,0	301,0	230-2,5-015-1100
1100	645	1360	1120,0	8,0	21	206	100,0	395,0	315,0	230-2,5-021-1100
1200	475	1425	1220,0	8,0	8	693	42,0	443,0	305,0	230-2,5-008-1200
1200	560	1425	1220,0	8,0	14	427	71,0	443,0	315,0	230-2,5-014-1200
1200	715	1425	1220,0	8,0	20	301	124,0	442,0	332,0	230-2,5-020-1200
1300	465	1535	1320,0	8,0	6	1090	37,0	830,0	367,0	230-2,5-006-1300
1300	525	1535	1320,0	8,0	9	753	61,0	830,0	373,0	230-2,5-009-1300
1300	640	1535	1320,0	8,0	16	388	108,0	828,0	391,0	230-2,5-016-1300
1400	495	1635	1420,0	8,0	5	1350	42,0	959,0	427,0	230-2,5-005-1400
1400	525	1635	1420,0	8,0	9	934	71,0	959,0	424,0	230-2,5-009-1400
1400	640	1635	1420,0	8,0	15	481	124,0	958,0	442,0	230-2,5-015-1400
1500	495	1755	1520,0	8,0	5	1710	48,0	1098,0	503,0	230-2,5-005-1500
1500	525	1755	1520,0	8,0	8	1150	81,0	1098,0	500,0	230-2,5-008-1500
1500	640	1755	1520,0	8,0	14	589	142,0	1097,0	520,0	230-2,5-014-1500
1600	495	1860	1620,0	8,0	5	2140	54,0	1245,0	568,0	230-2,5-005-1600
1600	525	1860	1620,0	8,0	7	1380	92,0	1247,0	564,0	230-2,5-007-1600
1600	640	1860	1620,0	8,0	13	711	162,0	1245,0	587,0	230-2,5-013-1600
1700	500	1945	1720,0	8,0	4	2640	63,0	1403,0	638,0	230-2,5-004-1700
1700	525	1945	1720,0	8,0	7	1650	104,0	1405,0	633,0	230-2,5-007-1700
1700	640	1945	1720,0	8,0	12	879	182,0	1403,0	656,0	230-2,5-012-1700
1800	530	2060	1820,0	8,0	4	3240	70,0	1961,0	767,0	230-2,5-004-1800
1800	525	2060	1820,0	8,0	7	1950	116,0	1965,0	751,0	230-2,5-007-1800
1800	640	2060	1820,0	8,0	12	1080	204,0	1961,0	778,0	230-2,5-012-1800

Weitere Abmessungen und Werkstoffe auf Anfrage. /  
Other dimensions and materials on request.

**Typ 230 Abmessungen  
Ausführung 1**

**Type 230 Specifications**

**Model 1**

**Druckstufe  
Design**

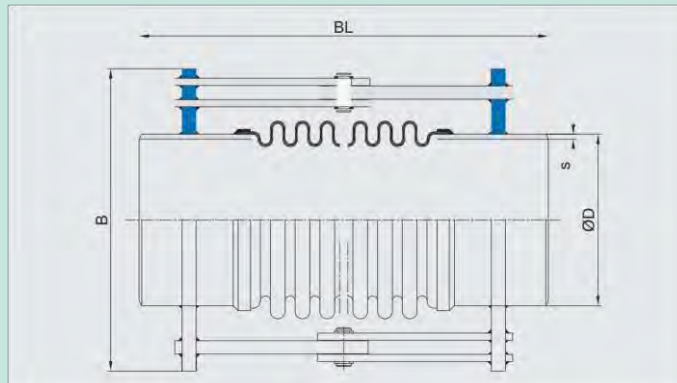

**2,5 barg (PN 2,5)  
pressure 2.5 barg (PN 2.5)**

DN	Länge Length		Größte Breite Biggest width		Anschweißenden Weld ends		Bewegungsaufnahme Movement angular	Verstellmomentrate Friction rate			Gewicht Weight	Artikel Article
	BL mm	B mm	ØD	s mm	mm	2αN %/deg.		Cα N/mm	Cp N/mm barg	Cr N/barg		
1900	500	2175	1920,0	8,0	3	4090	76	2184,0	894,0	<b>230-2,5-003-1900</b>		
1900	525	2175	1920,0	8,0	6	2370	129	1748,0	890,0	<b>230-2,5-006-1900</b>		
1900	645	2175	1920,0	8,0	11	1320	231	1748,0	919,0	<b>230-2,5-011-1900</b>		
2000	550	2290	2020,0	8,0	3	4940	85	2416,0	975,0	<b>230-2,5-003-2000</b>		
2000	545	2290	2020,0	8,0	6	2970	143	2416,0	955,0	<b>230-2,5-006-2000</b>		
2000	665	2290	2020,0	8,0	10	1650	255	2416,0	987,0	<b>230-2,5-010-2000</b>		

**Typ 230 Abmessungen**  
**Ausführung 1**

**Type 230 Specifications**

2100	525	2400	2120,0	8,0	4	4590	95	2127,0	1071,0	<b>230-2,5-004-2100</b>
2100	545	2400	2120,0	8,0	6	2650	157	2128,0	1068,0	<b>230-2,5-006-2100</b>
2100	665	2400	2120,0	8,0	12	1420	281	2129,0	1106,0	<b>230-2,5-012-2100</b>
2200	540	2500	2220,0	8,0	3	5260	102	2332,0	1251,0	<b>230-2,5-003-2200</b>
2200	545	2500	2220,0	8,0	6	3160	172	2332,0	1240,0	<b>230-2,5-006-2200</b>
2200	670	2500	2220,0	8,0	11	1760	313	2332,0	1283,0	<b>230-2,5-011-2200</b>

Weitere Abmessungen und Werkstoffe auf Anfrage. /



Typ 230 Abmessungen  
Ausführung 1

Type 230 Specifications

Model 1

Druckstufe 6  
Design

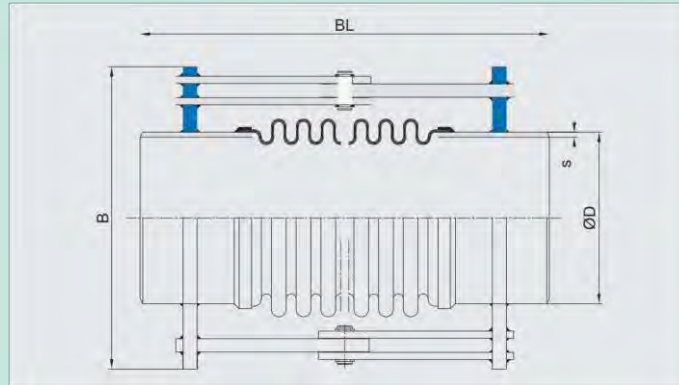

barg (PN 6)  
pressure 6 barg (PN 6)

DN	Länge Length		Größte Breite Biggest width		Anschweißenden Weld ends		Bewegungsaufnahme Movement angular	Verstellmomentrate Friction rate			Gewicht Weight kg	Artikel Article
	BL mm		B mm		ØD	s mm		mm	Cα N/mm	Cp N/mm barg		
50	355		190		60,3	2,9	48	0,8	0,1	0,4	6,2	230-06-048-0050
50	455		190		60,3	2,9	50	0,7	0,2	0,4	7,1	230-06-050-0050
65	345		205		76,1	2,9	40	1,1	0,2	0,6	7,4	230-06-040-0065
65	410		205		76,1	2,9	50	1,1	0,3	0,6	8,2	230-06-050-0065
80	305		235		88,9	3,2	31	1,9	0,2	0,9	8,0	230-06-031-0080
80	350		235		88,9	3,2	44	1,1	0,3	0,9	8,4	230-06-044-0080
100	315		265		114,3	3,6	30	1,9	0,3	1,5	10,7	230-06-030-0100
100	355		265		114,3	3,6	44	2,1	0,4	1,5	11,3	230-06-044-0100
125	325		290		139,7	4,0	25	3,1	0,4	3,6	16,7	230-06-025-0125
125	375		290		139,7	4,0	41	2,8	0,7	3,5	18,1	230-06-041-0125
150	335		325		168,3	4,5	24	5,0	0,6	5,1	20,1	230-06-024-0150
150	420		325		168,3	4,5	39	8,0	1,3	5,1	23,1	230-06-039-0150
200	360		380		219,1	6,3	23	6,3	1,2	12,0	35,8	230-06-023-0200
200	445		380		219,1	6,3	37	9,8	2,3	12,0	39,8	230-06-037-0200
250	350		440		273,0	6,3	17	15,0	1,8	18,0	37,2	230-06-017-0250
250	435		440		273,0	6,3	31	18,0	3,5	18,0	41,3	230-06-031-0250
300	390		495		323,9	7,1	19	24,0	2,5	25,0	53,7	230-06-019-0300
300	435		495		323,9	7,1	25	17,0	3,7	25,0	55,2	230-06-025-0300
300	495		495		323,9	7,1	35	26,0	5,3	25,0	61,0	230-06-035-0300
350	390		530		355,6	6,3	17	33,0	2,9	29,0	47,6	230-06-017-0350
350	435		530		355,6	6,3	24	19,0	4,5	30,0	51,2	230-06-024-0350
350	530		530		355,6	6,3	34	32,0	7,5	30,0	60,6	230-06-034-0350
400	430		605		406,4	6,3	17	42,0	5,5	39,0	66,3	230-06-017-0400
400	495		605		406,4	6,3	26	33,0	8,4	39,0	73,1	230-06-026-0400
400	635		605		406,4	6,3	35	61,0	15,0	38,0	90,6	230-06-035-0400
450	425		665		457,0	6,3	14	91,0	6,2	49,0	81,0	230-06-014-0450
450	480		665		457,0	6,3	20	50,0	9,1	49,0	84,9	230-06-020-0450
450	600		665		457,0	6,3	33	66,0	16,0	49,0	101,0	230-06-033-0450
500	435		730		508,0	6,3	13	110,0	8,4	60,0	101,0	230-06-013-0500
500	530		730		508,0	6,3	20	64,0	15,0	60,0	107,0	230-06-020-0500
500	630		730		508,0	6,3	32	87,0	22,0	60,0	130,0	230-06-032-0500
600	475		840		610,0	6,0	12	214,0	15,0	84,0	136,0	230-06-012-0600
600	540		840		610,0	6,0	22	120,0	21,0	86,0	148,0	230-06-022-0600
600	640		840		610,0	6,0	29	123,0	31,0	85,0	169,0	230-06-029-0600
700	475		945		711,0	6,0	10	368,0	20,0	112,0	165,0	230-06-010-0700
700	540		945		711,0	6,0	18	209,0	28,0	114,0	182,0	230-06-018-0700
700	675		945		711,0	6,0	26	186,0	45,0	113,0	207,0	230-06-026-0700
800	455		1055		813,0	8,0	10	526,0	21,0	210,0	253,0	230-06-010-0800
800	550		1055		813,0	8,0	16	301,0	36,0	210,0	265,0	230-06-016-0800
800	650		1055		813,0	8,0	24	214,0	53,0	211,0	293,0	230-06-024-0800
900	465		1190		914,0	8,0	8	758,0	26,0	263,0	305,0	230-06-008-0900

## Typ 230 Abmessungen Ausführung 1

### Type 230 Specifications

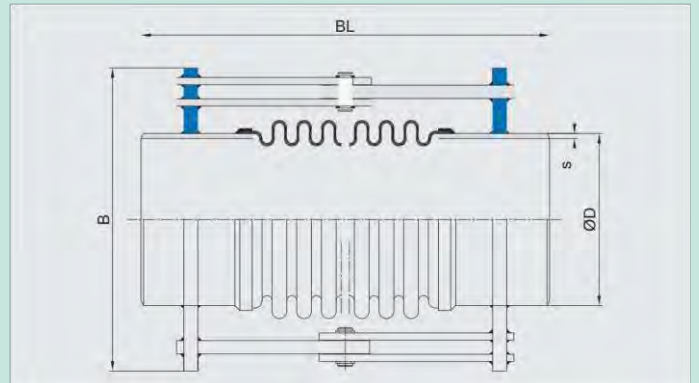

900	560	1190	914,0	8,0	14	416,0	45,0	264,0	326,0	<b>230-06-014-0900</b>
900	660	1190	914,0	8,0	22	307,0	66,0	265,0	358,0	<b>230-06-022-0900</b>
1000	500	1265	1016,0	8,0	7	1060,0	32,0	516,0	383,0	<b>230-06-007-1000</b>
1000	560	1265	1016,0	8,0	13	605,0	56,0	516,0	397,0	<b>230-06-013-1000</b>
1000	660	1265	1016,0	8,0	21	355,0	81,0	521,0	419,0	<b>230-06-021-1000</b>
1100	520	1415	1120,0	8,0	8	1390,0	49,0	391,0	463,0	<b>230-06-008-1100</b>
1100	615	1415	1120,0	8,0	12	869,0	78,0	391,0	479,0	<b>230-06-012-1100</b>
1100	680	1415	1120,0	8,0	19	508,0	99,0	397,0	508,0	<b>230-06-019-1100</b>

Weitere Abmessungen und Werkstoffe auf Anfrage.  
/ Other dimensions and materials on request.

## Model 1

### Druckstufe 6 barg (PN 6) Design pressure 6 barg (PN 6)

DN	Länge Length	Größte Breite Biggest width	Anschweißenden Weld ends		Bewegungsaufnahme Movement angular	Verstellmomentrate Friction rate			Gewicht Weight	Artikel Article
	BL mm		B mm	ØD		s mm	mm	2αN %/deg.		
1200	550	1465	1220,0	8,0	7	1710,0	53,0	700,0	504,0	<b>230-06-007-1200</b>
1200	645	1465	1220,0	8,0	12	934,0	86,0	701,0	522,0	<b>230-06-012-1200</b>
1200	745	1465	1220,0	8,0	19	560,0	120,0	707,0	565,0	<b>230-06-019-1200</b>
1300	520	1580	1320,0	8,0	4	3850,0	38,0	827,0	598,0	<b>230-06-004-1300</b>
1300	555	1580	1320,0	8,0	9	1680,0	65,0	832,0	607,0	<b>230-06-009-1300</b>
1300	655	1580	1320,0	8,0	12	1330,0	105,0	828,0	631,0	<b>230-06-012-1300</b>
1400	525	1700	1420,0	8,0	4	4740,0	45,0	957,0	758,0	<b>230-06-004-1400</b>
1400	555	1700	1420,0	8,0	8	2080,0	75,0	962,0	767,0	<b>230-06-008-1400</b>
1400	655	1700	1420,0	8,0	11	1640,0	121,0	958,0	795,0	<b>230-06-011-1400</b>
1500	545	1840	1520,0	8,0	4	5790,0	52,0	1096,0	872,0	<b>230-06-004-1500</b>
1500	575	1840	1520,0	8,0	7	2630,0	86,0	1101,0	882,0	<b>230-06-007-1500</b>
1500	675	1840	1520,0	8,0	11	2000,0	138,0	1097,0	913,0	<b>230-06-011-1500</b>
1600	545	1945	1620,0	8,0	3	6990,0	58,0	1244,0	981,0	<b>230-06-003-1600</b>
1600	575	1945	1620,0	8,0	7	3430,0	97,0	1248,0	990,0	<b>230-06-007-1600</b>
1600	675	1945	1620,0	8,0	10	2420,0	157,0	1246,0	1022,0	<b>230-06-010-1600</b>

**Typ 230 Abmessungen  
Ausführung 1**

**Type 230 Specifications**

1700	580	2040	1720,0	8,0	3	14800,0	69,0	1752,0	1183,0	<b>230-06-003-1700</b>
1700	580	2040	1720,0	8,0	6	6200,0	113,0	1761,0	1184,0	<b>230-06-006-1700</b>
1700	680	2040	1720,0	8,0	9	4020,0	181,0	1760,0	1223,0	<b>230-06-009-1700</b>
1800	630	2145	1820,0	8,0	3	17500,0	78,0	1961,0	1452,0	<b>230-06-003-1800</b>
1800	630	2145	1820,0	8,0	6	7050,0	127,0	1972,0	1452,0	<b>230-06-006-1800</b>
1800	690	2145	1820,0	8,0	9	4750,0	202,0	1970,0	1476,0	<b>230-06-009-1800</b>
1900	745	2245	1920,0	8,0	3	14900,0	86,0	2848,0	1683,0	<b>230-06-003-1900</b>
1900	745	2245	1920,0	8,0	5	8260,0	141,0	2851,0	1679,0	<b>230-06-005-1900</b>
1900	730	2245	1920,0	8,0	8	5570,0	225,0	2848,0	1662,0	<b>230-06-008-1900</b>
2000	745	2350	2020,0	8,0	3	17300,0	95,0	3151,0	1842,0	<b>230-06-003-2000</b>
2000	745	2350	2020,0	8,0	5	9600,0	155,0	3154,0	1839,0	<b>230-06-005-2000</b>
2000	730	2350	2020,0	8,0	8	6470,0	249,0	3151,0	1820,0	<b>230-06-008-2000</b>
2100	745	2490	2120,0	8,0	3	14900,0	102,0	3476,0	2170,0	<b>230-06-003-2100</b>
2100	745	2490	2120,0	8,0	5	11100,0	170,0	3473,0	2159,0	<b>230-06-005-2100</b>
2100	770	2490	2120,0	8,0	9	5720,0	306,0	3476,0	2168,0	<b>230-06-009-2100</b>
2200	750	2595	2220,0	8,0	3	17300,0	115,0	3809,0	2480,0	<b>230-06-003-2200</b>
2200	750	2595	2220,0	8,0	5	15800,0	194,0	3809,0	2470,0	<b>230-06-005-2200</b>
2200	745	2595	2220,0	8,0	9	7140,0	304,0	3810,0	2488,0	<b>230-06-009-2200</b>

Weitere Abmessungen und Werkstoffe auf Anfrage.  
/ Other dimensions and materials on request.

## Typ 230 Abmessungen

### Ausführung 1

### Type 230 Specifications

### Model 1

Druckstufe 10 barg (PN 10)

Design pressure 10 barg (PN 10)

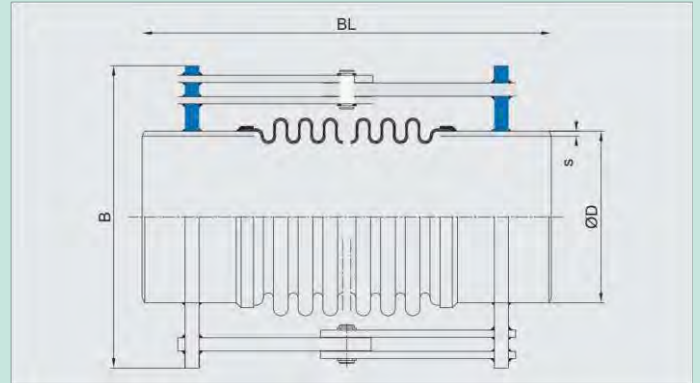

DN	Länge	Größte Breite	Anschweißenden		Bewegungsaufnahme	Verstellmomentrate			Gewicht	Artikel
	Length		Biggest width	Weld ends		Movement	Friction rate			
	BL	B	ØD	s	angular	Cα	Cp	Cr	kg	
	mm	mm	mm	mm	2αN	N/mm	N/mm barg	N/barg		
					%/deg.					
50	335	190	60,3	2,9	38	0,9	0,1	0,4	6,1	230-10-038-0050
50	405	190	60,3	2,9	50	0,9	0,2	0,4	6,9	230-10-050-0050
65	335	205	76,1	2,9	32	1,4	0,2	0,6	7,4	230-10-032-0065
65	400	205	76,1	2,9	49	1,3	0,2	0,6	8,1	230-10-049-0065
80	310	235	88,9	3,2	26	2,1	0,2	0,9	8,0	230-10-026-0080
80	385	235	88,9	3,2	50	3,6	0,4	0,9	9,5	230-10-050-0080
100	320	265	114,3	3,6	28	3,4	0,3	1,5	11,1	230-10-028-0100
100	355	265	114,3	3,6	35	2,8	0,4	1,5	11,6	230-10-035-0100
125	325	290	139,7	4,0	21	3,4	0,4	3,5	16,4	230-10-021-0125
125	365	290	139,7	4,0	30	4,1	0,6	3,5	17,6	230-10-030-0125
150	320	325	168,3	4,5	19	11,0	0,5	5,1	20,5	230-10-019-0150
150	405	325	168,3	4,5	33	7,6	1,2	5,1	22,3	230-10-033-0150
200	350	380	219,1	6,3	18	25,0	1,2	12,0	37,3	230-10-018-0200
200	395	380	219,1	6,3	27	12,0	1,7	12,0	38,3	230-10-027-0200
200	460	380	219,1	6,3	39	17,0	2,4	12,0	44,0	230-10-039-0200
250	340	440	273,0	6,3	15	43,0	1,6	18,0	37,8	230-10-015-0250
250	385	440	273,0	6,3	23	21,0	2,5	18,0	39,7	230-10-023-0250
250	470	440	273,0	6,3	33	30,0	4,1	18,0	48,5	230-10-033-0250
300	380	495	323,9	7,1	14	52,0	2,3	25,0	54,8	230-10-014-0300
300	465	495	323,9	7,1	26	31,0	4,5	25,0	59,1	230-10-026-0300
300	535	495	323,9	7,1	34	46,0	6,4	25,0	69,4	230-10-034-0300
350	390	535	355,6	6,3	12	72,0	2,6	30,0	58,5	230-10-012-0350
350	440	535	355,6	6,3	23	38,0	4,3	30,0	64,4	230-10-023-0350
350	515	535	355,6	6,3	29	47,0	6,6	29,0	70,2	230-10-029-0350
400	400	590	406,4	6,3	13	104,0	3,5	55,0	83,2	230-10-013-0400
400	520	590	406,4	6,3	22	59,0	8,5	55,0	90,6	230-10-022-0400
400	585	590	406,4	6,3	29	85,0	12,0	55,0	104,0	230-10-029-0400
450	440	675	457,0	8,8	16	107,0	6,3	48,0	113,0	230-10-016-0450
450	505	675	457,0	8,8	23	93,0	9,9	49,0	123,0	230-10-023-0450
450	635	675	457,0	8,8	31	124,0	17,0	48,0	149,0	230-10-031-0450
500	400	740	508,0	8,8	9	270,0	5,2	59,0	137,0	230-10-009-0500
500	480	740	508,0	8,8	20	126,0	11,0	60,0	148,0	230-10-020-0500
500	595	740	508,0	8,8	27	131,0	18,0	60,0	163,0	230-10-027-0500
600	425	845	610,0	8,0	8	562,0	8,9	119,0	189,0	230-10-008-0600
600	525	845	610,0	8,0	19	224,0	19,0	120,0	204,0	230-10-019-0600
600	705	845	610,0	8,0	27	237,0	35,0	121,0	245,0	230-10-027-0600
700	470	980	711,0	8,0	10	580,0	17,0	161,0	267,0	230-10-010-0700
700	565	980	711,0	8,0	16	331,0	28,0	161,0	289,0	230-10-016-0700
700	680	980	711,0	8,0	24	296,0	43,0	163,0	317,0	230-10-024-0700

## Typ 230 Abmessungen Ausführung 1

## Type 230 Specifications

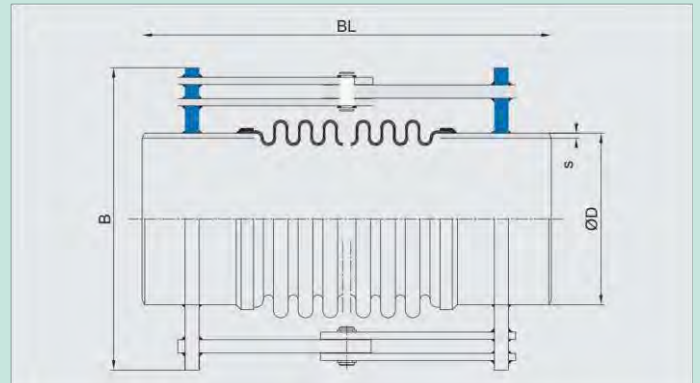

800	500	1095	813,0	8,0	8	965,0	22,0	211,0	337,0	230-10-008-0800
800	630	1095	813,0	8,0	15	483,0	43,0	211,0	358,0	230-10-015-0800
800	700	1095	813,0	8,0	20	360,0	55,0	213,0	383,0	230-10-020-0800
900	530	1190	914,0	8,0	8	1520,0	28,0	424,0	439,0	230-10-008-0900
900	570	1190	914,0	8,0	13	790,0	42,0	427,0	449,0	230-10-013-0900
900	735	1190	914,0	8,0	19	508,0	76,0	425,0	482,0	230-10-019-0900
1000	550	1320	1016,0	8,0	7	2030,0	34,0	520,0	556,0	230-10-007-1000
1000	590	1320	1016,0	8,0	11	1200,0	51,0	522,0	567,0	230-10-011-1000
1000	755	1320	1016,0	8,0	17	678,0	93,0	521,0	606,0	230-10-017-1000

Weitere Abmessungen und Werkstoffe auf Anfrage.  
/ Other dimensions and materials on request.

## Model 1

### Druckstufe 10 barg (PN 10)

### Design pressure 10 barg (PN 10)

DN	Länge Length	Größte Breite Biggest width	Anschweißenden Weld ends		Bewegungsaufnahme Movement angular	Verstellmomentrate Friction rate			Gewicht Weight	Artikel Article
			ØD	s mm		mm	C $\alpha$ N/mm	C $\rho$ N/mm barg		
1100	585	1430	1120,0	8,0	5	3680,0	31,0	794,0	695,0	230-10-005-1100
1100	630	1430	1120,0	8,0	12	1580,0	75,0	794,0	711,0	230-10-012-1100
1100	695	1430	1120,0	8,0	15	1230,0	94,0	794,0	739,0	230-10-015-1100
1200	555	1525	1220,0	8,0	5	3890,0	36,0	713,0	721,0	230-10-005-1200
1200	665	1525	1220,0	8,0	12	1670,0	83,0	713,0	760,0	230-10-012-1200
1200	730	1525	1220,0	8,0	15	1400,0	106,0	715,0	779,0	230-10-015-1200
1300	585	1645	1320,0	8,0	5	4880,0	41,0	1042,0	944,0	230-10-005-1300
1300	675	1645	1320,0	8,0	11	2090,0	97,0	1042,0	981,0	230-10-011-1300
1300	740	1645	1320,0	8,0	14	1750,0	123,0	1044,0	1004,0	230-10-014-1300
1400	670	1745	1420,0	8,0	4	6520,0	49,0	1207,0	1182,0	230-10-004-1400
1400	680	1745	1420,0	8,0	9	3260,0	95,0	1207,0	1185,0	230-10-009-1400
1400	780	1745	1420,0	8,0	13	2180,0	143,0	1207,0	1231,0	230-10-013-1400

Weitere Abmessungen und Werkstoffe auf Anfrage.  
/ Other dimensions and materials on request.

**Typ 230 Abmessungen  
Ausführung 1**

**Type 230 Specifications**



**Typ 230 Abmessungen  
Ausführung 1**

**Type 230 Specifications**

**barg (PN 16)  
pressure 16 barg (PN 16)**

**Model 1**

**Druckstufe 16  
Design**

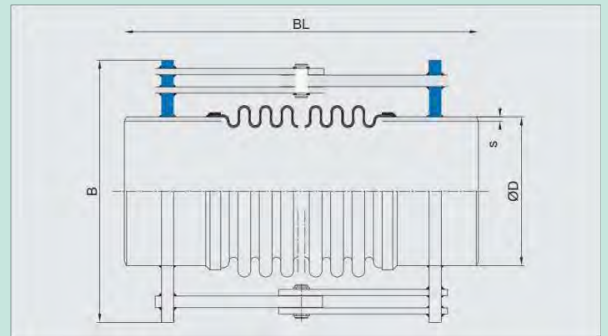

DN	Länge Length		Größte Breite Biggest width		Anschweißenden Weld ends		Bewegungsaufnahme Movement angular	Verstellmomentrate Friction rate			Gewicht Weight kg	Artikel Article
	BL mm	B mm	ØD	s mm	mm	2αN %/deg.		Cα N/mm	Cp N/mm barg	Cr N/barg		
50	335	190	60,3	2,9	34	0,9	0,1	0,4	6,1	230-16-034-0050		
50	415	190	60,3	2,9	50	1,5	0,2	0,4	7,1	230-16-050-0050		
65	335	205	76,1	2,9	28	1,4	0,2	0,6	7,4	230-16-028-0065		
65	410	205	76,1	2,9	50	2,3	0,3	0,6	8,5	230-16-050-0065		
80	310	235	88,9	3,2	22	2,1	0,2	0,9	8,0	230-16-022-0080		
80	385	235	88,9	3,2	46	3,6	0,4	0,9	9,5	230-16-046-0080		
100	320	265	114,3	3,6	24	3,4	0,3	1,5	11,1	230-16-024-0100		
100	365	265	114,3	3,6	37	4,8	0,5	1,4	12,4	230-16-037-0100		
125	315	290	139,7	4,0	15	9,0	0,4	3,5	16,7	230-16-015-0125		
125	355	290	139,7	4,0	26	6,5	0,6	3,6	17,7	230-16-026-0125		
125	390	290	139,7	4,0	32	7,5	0,7	3,5	19,7	230-16-032-0125		
150	325	325	168,3	4,5	16	19,0	0,6	5,1	21,1	230-16-016-0150		
150	355	325	168,3	4,5	23	9,9	0,8	5,2	21,3	230-16-023-0150		
150	415	325	168,3	4,5	35	14,0	1,2	5,0	25,0	230-16-035-0150		
200	335	380	219,1	6,3	16	32,0	0,9	12,0	37,9	230-16-016-0200		
200	400	380	219,1	6,3	25	18,0	1,7	12,0	40,5	230-16-025-0200		
200	490	380	219,1	6,3	33	32,0	2,8	12,0	48,0	230-16-033-0200		
250	375	465	273,0	6,3	14	47,0	1,9	18,0	57,9	230-16-014-0250		
250	410	465	273,0	6,3	21	33,0	2,6	18,0	61,4	230-16-021-0250		
250	520	465	273,0	6,3	28	53,0	4,6	18,0	71,9	230-16-028-0250		
300	385	530	323,9	7,1	10	105,0	1,8	25,0	88,7	230-16-010-0300		
300	440	530	323,9	7,1	20	54,0	3,3	25,0	94,5	230-16-020-0300		
300	540	530	323,9	7,1	26	63,0	6,0	25,0	103,0	230-16-026-0300		
350	415	565	355,6	8,0	11	116,0	2,8	29,0	83,3	230-16-011-0350		
350	450	565	355,6	8,0	18	75,0	3,9	30,0	90,3	230-16-018-0350		
350	545	565	355,6	8,0	25	77,0	6,9	29,0	104,0	230-16-025-0350		
400	445	620	406,4	8,8	13	163,0	4,5	55,0	123,0	230-16-013-0400		
400	510	620	406,4	8,8	18	108,0	7,2	55,0	127,0	230-16-018-0400		
400	535	620	406,4	8,8	22	92,0	8,4	55,0	135,0	230-16-022-0400		
450	455	715	457,0	8,8	11	252,0	5,6	48,0	152,0	230-16-011-0450		
450	520	715	457,0	8,8	16	158,0	9,0	48,0	157,0	230-16-016-0450		
450	545	715	457,0	8,8	20	127,0	11,0	48,0	166,0	230-16-020-0450		
500	485	735	508,0	8,8	11	344,0	8,9	84,0	169,0	230-16-011-0500		
500	540	735	508,0	8,8	14	246,0	13,0	84,0	180,0	230-16-014-0500		
500	570	735	508,0	8,8	20	172,0	15,0	85,0	189,0	230-16-020-0500		
600	480	870	610,0	8,0	7	988,0	9,5	121,0	248,0	230-16-007-0600		
600	550	870	610,0	8,0	12	593,0	16,0	121,0	258,0	230-16-012-0600		
600	685	870	610,0	8,0	18	330,0	29,0	121,0	275,0	230-16-018-0600		
700	530	985	711,0	8,0	7	1390,0	13,0	264,0	354,0	230-16-007-0700		
700	550	985	711,0	8,0	11	983,0	22,0	263,0	356,0	230-16-011-0700		
700	655	985	711,0	8,0	16	614,0	35,0	263,0	376,0	230-16-016-0700		

## Typ 230 Abmessungen Ausführung 1

### Type 230 Specifications

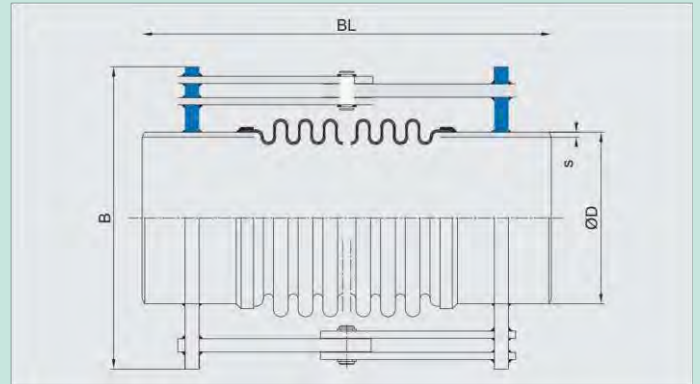

800	540	1115	813,0	8,0	7	2010,0	24,0	338,0	458,0	230-16-007-0800
800	605	1115	813,0	8,0	11	1230,0	34,0	339,0	477,0	230-16-011-0800
800	745	1115	813,0	8,0	16	839,0	57,0	338,0	505,0	230-16-016-0800
900	545	1250	914,0	8,0	6	4250,0	30,0	424,0	616,0	230-16-006-0900
900	610	1250	914,0	8,0	10	2110,0	44,0	427,0	639,0	230-16-010-0900
900	750	1250	914,0	8,0	16	1090,0	73,0	429,0	684,0	230-16-016-0900
1000	630	1370	1016,0	8,0	5	5950,0	36,0	649,0	855,0	230-16-005-1000
1000	650	1370	1016,0	8,0	9	2830,0	54,0	654,0	867,0	230-16-009-1000
1000	790	1370	1016,0	8,0	14	1510,0	89,0	656,0	921,0	230-16-014-1000

Weitere Abmessungen und Werkstoffe auf Anfrage.  
/ Other dimensions and materials on request.

## Model 1

### Druckstufe 25 barg (PN 25)

#### Design pressure 25 barg (PN 25)

DN	Länge Length	Größte Breite Biggest width	Anschweißenden Weld ends		Bewegungsaufnahme Movement angular	Verstellmomentrate Friction rate			Gewicht Weight kg	Artikel Article
			ØD	s mm		mm	C $\alpha$ N/mm	C $p$ N/mm barg		
50	325	190	60,3	4,0	27	1,0	0,1	0,4	6,4	230-25-027-0050
50	380	190	60,3	4,0	44	1,9	0,2	0,4	7,0	230-25-044-0050
65	335	205	76,1	4,0	24	1,8	0,2	0,5	7,8	230-25-024-0065
65	425	205	76,1	4,0	43	3,5	0,3	0,5	9,3	230-25-043-0065
80	310	235	88,9	4,0	23	3,2	0,2	0,9	8,6	230-25-023-0080



## Typ 230 Abmessungen Ausführung 1

### Type 230 Specifications

80	360	235	88,9	4,0	36	4,4	0,3	0,9	9,8	230-25-036-0080
100	310	265	114,3	4,0	21	6,0	0,3	1,5	11,6	230-25-021-0100
100	365	265	114,3	4,0	30	6,6	0,5	1,4	12,2	230-25-030-0100
125	345	290	139,7	4,0	19	9,5	0,5	3,5	18,1	230-25-019-0125
125	385	290	139,7	4,0	28	12,0	0,7	3,4	20,5	230-25-028-0125
150	335	325	168,3	4,5	16	24,0	0,6	5,1	22,1	230-25-016-0150
150	410	325	168,3	4,5	27	19,0	1,2	5,0	25,1	230-25-027-0150
200	350	380	219,1	6,3	14	53,0	0,9	12,0	39,5	230-25-014-0200
200	400	380	219,1	6,3	22	26,0	1,6	12,0	42,5	230-25-022-0200
250	370	465	273,0	7,1	10	117,0	1,4	18,0	62,3	230-25-010-0250
250	425	465	273,0	7,1	17	58,0	2,4	18,0	66,4	230-25-017-0250
250	485	465	273,0	7,1	22	60,0	3,6	18,0	71,9	230-25-022-0250
300	430	530	323,9	8,0	11	148,0	2,4	24,0	96,3	230-25-011-0300
300	480	530	323,9	8,0	15	93,0	3,7	24,0	99,7	230-25-015-0300
300	505	530	323,9	8,0	19	79,0	4,5	25,0	106,0	230-25-019-0300
350	440	560	355,6	8,0	9	207,0	2,9	41,0	112,0	230-25-009-0350
350	490	560	355,6	8,0	14	129,0	4,5	41,0	116,0	230-25-014-0350
350	515	560	355,6	8,0	18	108,0	5,3	42,0	122,0	230-25-018-0350
400	450	625	406,4	8,8	8	401,0	3,8	54,0	146,0	230-25-008-0400
400	495	625	406,4	8,8	13	237,0	5,7	54,0	146,0	230-25-013-0400
400	590	625	406,4	8,8	19	160,0	9,7	55,0	161,0	230-25-019-0400
450	445	715	457,0	8,8	5	764,0	3,5	69,0	193,0	230-25-005-0450
450	515	715	457,0	8,8	11	382,0	7,2	69,0	200,0	230-25-011-0450
450	610	715	457,0	8,8	17	243,0	13,0	70,0	218,0	230-25-017-0450
500	465	775	508,0	8,8	6	1040,0	5,7	85,0	228,0	230-25-006-0500
500	555	775	508,0	8,8	12	573,0	12,0	85,0	240,0	230-25-012-0500
500	640	775	508,0	8,8	16	345,0	18,0	85,0	254,0	230-25-016-0500
600	560	890	610,0	10,0	6	2190,0	10,0	195,0	361,0	230-25-006-0600
600	600	890	610,0	10,0	10	1200,0	18,0	196,0	368,0	230-25-010-0600
600	705	890	610,0	10,0	15	685,0	28,0	196,0	390,0	230-25-015-0600
700	565	1045	711,0	10,0	6	2860,0	15,0	266,0	520,0	230-25-006-0700
700	605	1045	711,0	10,0	8	2490,0	24,0	262,0	527,0	230-25-008-0700
700	710	1045	711,0	10,0	14	1040,0	38,0	266,0	565,0	230-25-014-0700

Weitere Abmessungen und Werkstoffe auf Anfrage.  
/ Other dimensions and materials on request.

**Typ 230 Abmessungen  
Ausführung 1**

**Type 230 Specifications**

**Model 1**

**Druckstufe 40 barg (PN 40)  
Design pressure 40 barg (PN 40)**

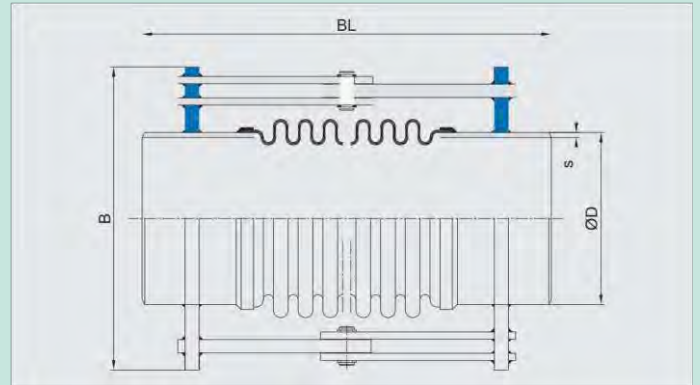

DN	Länge Length	Größte Breite Biggest width	Anschweißenden Weld ends		Bewegungsaufnahme Movement angular	Verstellmomentrate Friction rate			Gewicht Weight	Artikel Article
			ØD	s		mm	mm	C $\alpha$ N/mm		
50	320	190	60,3	4,0	26	1,9	0,1	0,4	6,3	230-40-026-0050
50	360	190	60,3	4,0	32	2,5	0,1	0,4	6,9	230-40-032-0050
65	335	205	76,1	4,0	25	2,9	0,2	0,5	7,8	230-40-025-0065
65	385	205	76,1	4,0	35	4,9	0,2	0,6	8,7	230-40-035-0065
80	345	235	88,9	4,0	21	5,6	0,2	1,5	14,8	230-40-021-0080
80	390	235	88,9	4,0	29	8,0	0,3	1,6	16,4	230-40-029-0080
100	365	265	114,3	4,0	17	9,2	0,4	2,3	17,4	230-40-017-0100
100	415	265	114,3	4,0	24	14,0	0,5	2,5	19,3	230-40-024-0100
125	380	320	139,7	4,0	17	17,0	0,5	3,4	29,2	230-40-017-0125
125	425	320	139,7	4,0	21	19,0	0,7	3,6	31,0	230-40-021-0125
150	405	355	168,3	4,5	18	30,0	0,8	6,8	44,7	230-40-018-0150
150	470	355	168,3	4,5	22	35,0	1,4	7,3	48,5	230-40-022-0150
200	450	415	219,1	6,3	17	68,0	1,6	16,0	77,4	230-40-017-0200
200	485	415	219,1	6,3	19	58,0	2,3	17,0	80,2	230-40-019-0200
250	470	510	273,0	7,1	14	113,0	2,5	25,0	127,0	230-40-014-0250
250	555	510	273,0	7,1	18	108,0	4,0	26,0	138,0	230-40-018-0250
300	555	580	323,9	8,0	13	200,0	3,6	35,0	187,0	230-40-013-0300
300	635	580	323,9	8,0	16	155,0	6,0	36,0	198,0	230-40-016-0300
350	495	600	355,6	8,0	8	441,0	3,1	41,0	156,0	230-40-008-0350
350	595	600	355,6	8,0	14	235,0	6,4	43,0	169,0	230-40-014-0350

## Typ 230 Abmessungen Ausführung 1

## Type 230 Specifications

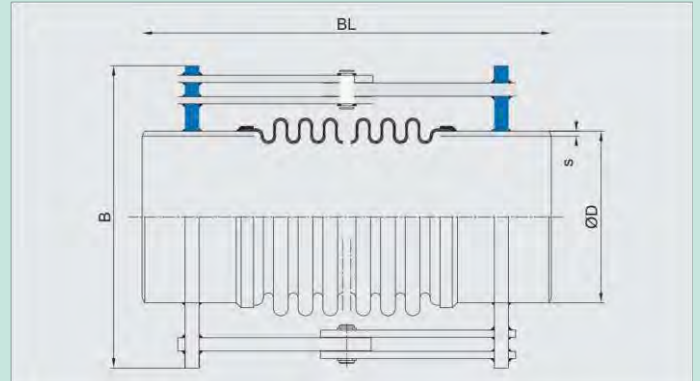

400	520	670	406,4	10,0	9	604,0	5,0	54,0	214,0	230-40-009-0400
400	620	670	406,4	10,0	13	448,0	9,4	55,0	228,0	230-40-013-0400
450	515	745	457,0	10,0	6	1290,0	5,1	109,0	287,0	230-40-006-0450
450	660	745	457,0	10,0	13	523,0	13,0	110,0	317,0	230-40-013-0450
500	575	780	508,0	10,0	6	1660,0	6,8	137,0	331,0	230-40-006-0500
500	665	780	508,0	10,0	12	699,0	15,0	137,0	353,0	230-40-012-0500

Weitere Abmessungen und Werkstoffe auf Anfrage.  
/ Other dimensions and materials on request.

## Model 1

### Druckstufe 63 barg (PN 63) Design pressure 63 barg (PN 63)

DN	Länge Length	Größte Breite Biggest width	Anschweißenden Weld ends		Bewegungsaufnahme Movement angular	Verstellmomentrate Friction rate			Gewicht Weight	Artikel Article
	BL mm	B mm	ØD	s mm		mm	C <sub>α</sub> N/mm	C <sub>p</sub> N/mm barg		
50	305	190	60,3	4,0	13	6,4	0,1	0,4	6,3	230-63-013-0050
50	345	190	60,3	4,0	20	4,1	0,1	0,4	6,7	230-63-020-0050
65	315	205	76,1	4,0	13	9,7	0,1	0,5	8,0	230-63-013-0065
65	365	205	76,1	4,0	18	8,2	0,2	0,6	8,3	230-63-018-0065
80	335	235	88,9	4,0	13	15,0	0,2	1,4	14,9	230-63-013-0080

**Typ 230 Abmessungen**  
**Ausführung 1**

**Type 230 Specifications**

80	375	235	88,9	4,0	18	9,6	0,3	1,6	15,4	<b>230-63-018-0080</b>
100	340	265	114,3	5,0	8	37,0	0,2	2,3	18,1	<b>230-63-008-0100</b>
100	390	265	114,3	5,0	14	20,0	0,4	2,4	18,8	<b>230-63-014-0100</b>
125	365	320	139,7	6,3	9	54,0	0,3	3,4	31,9	<b>230-63-009-0125</b>
125	445	320	139,7	6,3	16	29,0	0,7	3,6	34,1	<b>230-63-016-0125</b>
150	385	355	168,3	6,3	9	135,0	0,6	6,5	45,9	<b>230-63-009-0150</b>
150	450	355	168,3	6,3	16	53,0	1,2	7,2	50,2	<b>230-63-016-0150</b>
200	430	415	219,1	8,0	7	237,0	0,8	16,0	81,7	<b>230-63-007-0200</b>
200	490	415	219,1	8,0	13	142,0	1,9	17,0	85,5	<b>230-63-013-0200</b>
250	460	510	273,0	10,0	7	460,0	1,6	25,0	137,0	<b>230-63-007-0250</b>
250	545	510	273,0	10,0	12	254,0	3,3	26,0	147,0	<b>230-63-012-0250</b>
300	525	580	323,9	11,0	6	872,0	2,3	34,0	198,0	<b>230-63-006-0300</b>
300	655	580	323,9	11,0	12	438,0	6,0	36,0	215,0	<b>230-63-012-0300</b>
350	570	610	355,6	12,5	7	853,0	3,3	65,0	242,0	<b>230-63-007-0350</b>
350	630	610	355,6	12,5	12	485,0	6,4	69,0	254,0	<b>230-63-012-0350</b>
400	575	675	406,4	14,2	6	1830,0	4,6	86,0	312,0	<b>230-63-006-0400</b>
400	650	675	406,4	14,2	10	1130,0	8,4	90,0	327,0	<b>230-63-010-0400</b>

Weitere Abmessungen und Werkstoffe auf Anfrage.  
/ Other dimensions and materials on request.



## Angularkompensator mit Festflanschen und einfacher Gelenkverspannung

### Typ 232

Der Typ 232 ist ein mehrlagiger Angularkompensator mit Festflanschen, einseitig beweglich. Die Verspannung ist auf die Anschlüsse aufgeschweißt.

Er ist speziell konzipiert für den Betrieb in Anlagen mit Betriebsdrücken bis 63 barg (auf Anfrage).

Dieser Kompensator lässt angulare Bewegungen zu.

Durch Hintereinanderschaltung zweier Kompensatoren lassen sich auch große laterale Bewegungen realisieren.

#### Beschreibung

Neben den aufgeführten Standardbaulängen kann die Baulänge speziell auf Ihre Bedürfnisse angepasst gefertigt werden. Dieser Kompensator kann auch in anderen Werkstoffen (siehe Seite 179) gefertigt werden.

#### Anforderungen

- Strömungsumlenkung/Umlenkung des Rohrleitungssystems erforderlich
- Höherer Platzbedarf als Axialkompensatoren
- Für ein System sind zwei oder drei Kompensatoren erforderlich

#### Vorteile

- Nimmt große Bewegung in seitlicher Richtung auf
- Verringert die auf alle Festpunkte wirkenden Lasten

## Typ 233 (mit Innenleitrohr) Angular expansion joint with fixed flanges and single hinge construction

### Type 232

### Type 233 (with internal sleeve)



Type 232 is a multi-layer angular expansion joint with fixed flanges. This expansion joint has a hinge construction.

It is designed specifically for operation in installations with operating pressures up to 63 barg (on request).

This expansion joint allows angular movements.

Two expansion joints can be arranged in tandem to also allow large lateral movements.

#### Description

In addition to the given standard lengths, other lengths are available to meet specific requirements. This expansion joint can also be produced in other materials (see page 179).

#### Requirements

- Flow deflection/redirection of pipe system necessary
- More space required than for axial expansion joints
- Two or three expansion joints required for one system

#### Advantages

- Suitable for large movements in lateral direction
- Reduces loads exerted on all fixed points



**Typ 232 Abmessungen  
Ausführung 1**

**Type 232 Specifications**

**Model 1**

**Druckstufe 6 barg (PN 6)  
Design pressure 6 barg (PN 6)**

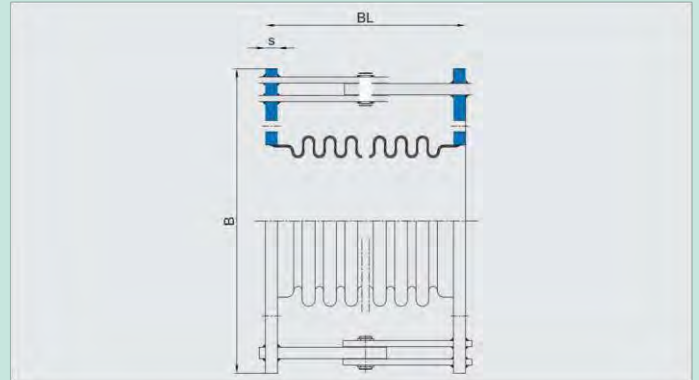

DN	Länge Length		Größte Breite Biggest width		Flansch Flanges		Bewegungsaufnahme Movement		Verstellmomentrate Frinction rate			Gewicht Weight	Artikel Article
	BL mm	B mm	s mm	2αN °/deg.	Cα N/mm	Cp N/mm barg	Cr N/barg	kg					
50	150	260	17	48	0,8	0,1	0,4	7,7	232-06-048-0050				
50	245	260	17	50	0,7	0,2	0,4	8,6	232-06-050-0050				
65	140	280	17	40	1,1	0,2	0,6	8,6	232-06-040-0065				
65	205	280	17	50	1,1	0,3	0,6	9,5	232-06-050-0065				
80	125	295	17	31	1,9	0,2	0,9	10,2	232-06-031-0080				
80	170	295	17	43	1,1	0,3	0,9	10,6	232-06-043-0080				
100	135	330	17	30	1,9	0,3	1,5	11,6	232-06-030-0100				
100	175	330	17	44	2,1	0,4	1,5	12,4	232-06-044-0100				
125	135	365	17	25	3,1	0,4	2,3	13,4	232-06-025-0125				
125	185	365	17	41	2,8	0,7	2,1	14,3	232-06-041-0125				
150	150	395	17	24	5,0	0,6	5,1	16,3	232-06-024-0150				
150	230	395	17	39	8,0	1,3	5,1	19,0	232-06-039-0150				
200	165	435	22	23	6,3	1,2	8,4	23,4	232-06-023-0200				
200	250	435	22	37	9,8	2,3	8,4	27,6	232-06-037-0200				
250	165	520	22	17	15,0	1,8	13,0	30,2	232-06-017-0250				
250	250	520	22	31	18,0	3,4	13,0	35,4	232-06-031-0250				
300	180	585	22	19	24,0	2,6	25,0	42,2	232-06-019-0300				
300	275	585	22	35	26,0	5,3	25,0	52,4	232-06-035-0300				
350	225	585	27	24	19,0	4,5	30,0	53,8	232-06-024-0350				
350	320	585	27	34	32,0	7,4	30,0	61,3	232-06-034-0350				
400	225	655	27	17	42,0	5,5	39,0	60,4	232-06-017-0400				
400	290	655	27	26	33,0	8,4	39,0	65,8	232-06-026-0400				
450	210	710	27	14	91,0	6,1	69,0	74,9	232-06-014-0450				
450	265	710	27	20	50,0	9,1	70,0	79,4	232-06-020-0450				
500	230	760	27	13	110,0	8,1	60,0	72,3	232-06-013-0500				
500	330	760	27	20	64,0	15,0	60,0	79,1	232-06-020-0500				
600	295	880	37	12	214,0	15,0	84,0	118,0	232-06-012-0600				
600	360	880	37	22	120,0	21,0	86,0	130,0	232-06-022-0600				
700	360	995	37	18	209,0	28,0	114,0	149,0	232-06-018-0700				
700	500	995	37	26	186,0	45,0	113,0	177,0	232-06-026-0700				
800	370	1110	42	16	301,0	36,0	210,0	211,0	232-06-016-0800				
800	475	1110	42	24	214,0	53,0	211,0	239,0	232-06-024-0800				

Weitere Abmessungen und Werkstoffe auf Anfrage. /  
Other dimensions and materials on request.

## Typ 232 Abmessungen Ausführung 1

## Type 232 Specifications

### Model 1

**Druckstufe 10 barg (PN 10)**  
Design pressure 10 barg (PN 10)

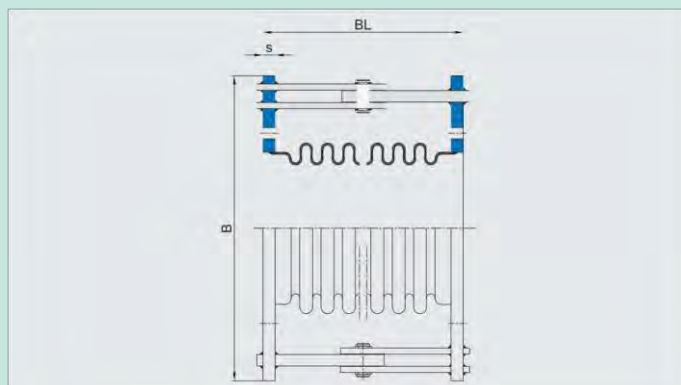

DN	Länge Length	Größte Breite Biggest width	Flansch Flanges	Bewegungsaufnahme Movement angular	Verstellmomentrate Friction rate			Gewicht Weight	Artikel Article
	BL mm	B mm	s mm	2αN %/deg.	Cα N/mm	Cp N/mm barg	Cr N/barg	kg	
50	140	260	22	38	0,9	0,1	0,4	10,7	232-10-038-0050
50	205	260	22	50	0,9	0,2	0,4	11,5	232-10-050-0050
65	140	280	22	31	1,4	0,2	0,6	11,9	232-10-031-0065
65	205	280	22	49	1,3	0,2	0,6	12,7	232-10-049-0065
80	135	295	22	26	2,1	0,2	0,9	13,1	232-10-026-0080
80	215	295	22	50	3,6	0,4	0,9	14,6	232-10-050-0080
100	140	330	22	28	3,4	0,3	1,5	15,1	232-10-028-0100
100	175	330	22	35	2,8	0,4	1,5	15,8	232-10-035-0100

Other dimensions and materials on request.



## Typ 232 Abmessungen Ausführung 1

### Type 232 Specifications

125	175	365	22	30	4,1	0,6	2,1	18,3	232-10-030-0125
125	255	365	22	42	7,0	1,0	2,1	20,8	232-10-042-0125
150	140	395	22	19	11,0	0,5	5,1	22,1	232-10-019-0150
150	220	395	22	33	7,6	1,2	5,1	24,4	232-10-033-0150
200	205	435	22	27	12,0	1,7	8,4	28,6	232-10-027-0200
200	275	435	22	38	17,0	2,5	8,2	33,1	232-10-038-0200
250	215	520	27	23	21,0	2,5	13,0	42,4	232-10-023-0250
250	300	520	27	33	30,0	4,0	13,0	50,3	232-10-033-0250
300	165	585	27	14	52,0	2,1	25,0	51,7	232-10-014-0300
300	255	585	27	26	31,0	4,5	25,0	58,5	232-10-026-0300
350	220	600	27	23	38,0	4,3	30,0	61,3	232-10-023-0350
350	300	600	27	29	47,0	6,7	29,0	69,0	232-10-029-0350
400	190	690	32	13	104,0	3,5	39,0	83,7	232-10-013-0400
400	375	690	32	29	85,0	12,0	38,0	106,0	232-10-029-0400
450	240	740	37	16	107,0	6,5	69,0	113,0	232-10-016-0450
450	305	740	37	23	93,0	9,9	69,0	124,0	232-10-023-0450
500	290	805	37	20	126,0	11,0	60,0	127,0	232-10-020-0500

## Typ 232 Abmessungen Ausführung 1

### Type 232 Specifications

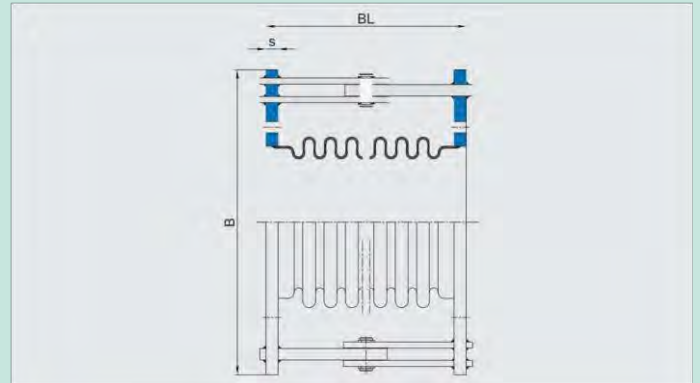

500	410	805	37	26	131,0	19,0	60,0	143,0	232-10-026-0500
600	250	945	43	8	562,0	8,9	119,0	177,0	232-10-008-0600
600	350	945	43	19	224,0	18,0	120,0	193,0	232-10-019-0600

Weitere Abmessungen und Werkstoffe auf Anfrage. /

## Model 1

### Druckstufe 16 barg (PN 16) Design pressure 16 barg (PN 16)

DN	Länge Length	Größte Breite Biggest width	Flansch Flanges	Bewegungsaufnahme Movement angular	Verstellmomentrate Frinction rate			Gewicht Weight kg	Artikel Article
	BL mm	B mm	s mm	2αN °/deg.	Cα N/mm	Cp N/mm barg	Cr N/barg		
50	140	260	22	34	0,9	0,1	0,4	10,7	232-16-034-0050

## Typ 232 Abmessungen Ausführung 1

### Type 232 Specifications

50	215	260	22	50	1,5	0,2	0,4	11,8	232-16-050-0050
65	140	280	22	27	1,4	0,2	0,6	11,9	232-16-027-0065
65	215	280	22	50	2,3	0,3	0,6	13,4	232-16-050-0065
80	135	295	22	23	2,1	0,2	0,9	13,1	232-16-023-0080
80	215	295	22	46	3,6	0,4	0,9	14,6	232-16-046-0080
100	140	330	22	24	3,4	0,3	1,5	15,1	232-16-024-0100
100	190	330	22	37	4,8	0,5	1,4	16,3	232-16-037-0100
125	165	365	22	26	6,5	0,6	2,3	18,7	232-16-026-0125
125	200	365	22	32	7,5	0,7	2,1	20,5	232-16-032-0125
150	175	395	22	23	9,9	0,8	5,2	23,1	232-16-023-0150
150	240	395	22	35	14,0	1,3	5,0	26,6	232-16-035-0150
200	225	435	27	25	18,0	1,8	8,4	34,4	232-16-025-0200
200	315	435	27	33	32,0	2,8	8,1	41,4	232-16-033-0200
250	205	560	32	14	47,0	1,9	18,0	58,4	232-16-014-0250
250	245	560	32	21	33,0	2,8	18,0	62,9	232-16-021-0250
300	230	585	32	20	54,0	3,2	25,0	68,5	232-16-020-0300
300	320	585	32	26	63,0	5,8	25,0	80,7	232-16-026-0300

**Typ 232 Abmessungen**  
**Ausführung 1**

**Type 232 Specifications**

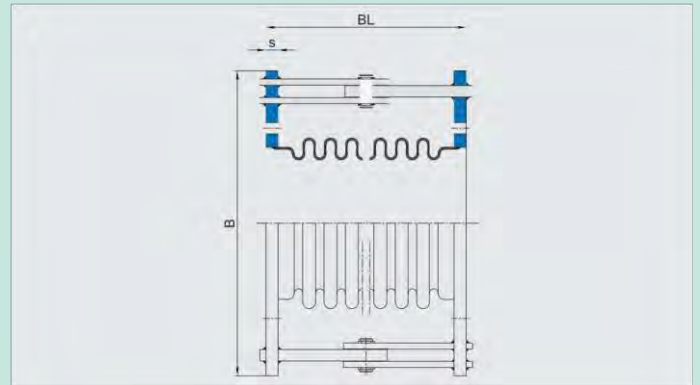

350	195	655	37	11	116,0	2,8	29,0	91,0	232-16-011-0350
350	230	655	37	18	75,0	3,8	30,0	95,9	232-16-018-0350

Weitere Abmessungen und Werkstoffe auf Anfrage. /  
Weitere Abmessungen und Werkstoffe auf Anfrage.

**Model 1**

**Druckstufe 25 barg (PN 25)**  
**Design pressure 25 barg (PN 25)**

DN	Länge Length	Größte Breite Biggest width	Flansch Flanges	Bewegungsaufnahme Movement angular	Verstellmomentrate Friction rate			Gewicht Weight	Artikel Article
	BL mm				B mm	s mm	2αN %/deg.		
50	130	260	22	27	1,0	0,1	0,4	10,7	232-25-027-0050
50	185	260	22	43	1,9	0,2	0,4	11,3	232-25-043-0050

**Typ 232 Abmessungen**  
**Ausführung 1**

**Type 232 Specifications**

65	135	280	22	24	1,8	0,2	0,5	11,9	232-25-024-0065
65	230	280	22	43	3,5	0,3	0,5	13,4	232-25-043-0065
80	140	295	22	23	3,2	0,2	0,9	13,3	232-25-023-0080
80	190	295	22	36	4,4	0,3	0,9	14,5	232-25-036-0080
100	130	330	22	21	6,0	0,3	1,5	16,5	232-25-021-0100
100	190	330	22	30	6,6	0,5	1,4	17,6	232-25-030-0100
125	155	365	22	19	9,5	0,5	2,1	20,2	232-25-019-0125
125	200	365	22	28	12,0	0,7	2,1	22,5	232-25-028-0125
150	165	395	27	16	24,0	0,6	5,1	28,8	232-25-016-0150
150	235	395	27	27	19,0	1,2	5,0	31,3	232-25-027-0150
200	175	485	32	14	53,0	1,0	12,0	51,3	232-25-014-0200
200	225	485	32	21	26,0	1,6	12,0	53,4	232-25-021-0200
250	235	560	37	17	58,0	2,4	18,0	75,5	232-25-017-0250
250	305	560	37	22	60,0	3,5	18,0	81,5	232-25-022-0250
300	265	650	43	15	93,0	3,7	24,0	105,0	232-25-015-0300
300	290	650	43	19	79,0	4,5	25,0	113,0	232-25-019-0300
350	265	690	42	14	129,0	4,5	29,0	123,0	232-25-014-0350

## Typ 232 Abmessungen Ausführung 1

### Type 232 Specifications

350	290	690	42	18	108,0	5,3	29,0	128,0	232-25-018-0350
-----	-----	-----	----	----	-------	-----	------	-------	-----------------

Weitere Abmessungen und Werkstoffe auf Anfrage. /  
Weitere Abmessungen und Werkstoffe auf Anfrage.



## Angularkompensator mit Anschweißenden und Kardangelen

### Typ 234

Der Typ 234 ist ein mehrlagiger Angularkompensator mit Anschweißenden mit Kardangelen und allseitig beweglich. Die Verspannung ist auf die Anschlüsse aufgeschweißt.

Er ist speziell konzipiert für den Betrieb in Anlagen mit Betriebsdrücken bis 63 barg.

Dieser Kompensator lässt allseitige angulare Bewegungen zu.

#### Beschreibung

Neben den aufgeführten Standardbaulängen kann die Baulänge speziell auf Ihre Bedürfnisse angepasst gefertigt werden. Dieser Kompensator kann auch in anderen Werkstoffen (siehe Seite 179) gefertigt werden.

#### Anforderungen

- Strömungsumlenkung/Umlenkung des Rohrleitungssystems erforderlich
- Höherer Platzbedarf als Axialkompensatoren
- Für ein System sind zwei oder drei Kompensatoren erforderlich

#### Vorteile

- Nimmt Bewegungen in verschiedenen Richtungen auf
- Verwendung normaler Loslager
- Verringert die auf alle Festpunkte wirkenden Lasten

## Typ 235 (mit Innenleitrohr) Angular expansion joint with weld ends and gimbal hinge

### Type 234

### Type 235 (with internal sleeve)



Type 234 is a multi-layer angular expansion joint with weld and gimbal hinge and moveable in all directions. This expansion joint has a gimbal hinge construction.

It is designed specifically for operation in installations with operating pressures up to 63 barg.

This expansion joint allows angular movements in all plains.

#### Description

In addition to the given standard lengths, other lengths are available to meet specific requirements. This expansion joint can also be produced in other materials (see page 179).

#### Requirements

- Flow deflection/redirection of pipe system necessary
- More space required than for axial expansion joints
- Two or three expansion joints required for one system

#### Advantages

- Suitable for large movements in lateral direction
- Reduces loads exerted on all fixed points

## Angularkompensator      Angular expansion mit Anschweißenden und      joint with weld ends and gimbal

## Kardangelenk

### Typ 234

### Typ 235 (mit Innenleitrohr)

<b>Einsatzbeispiele</b>	Dampfanlagen, Wasser, Entwässerung etc.
<b>Standardmäßiger Aufbau</b>	Mehrlagiger Wellrohrbalg aus 1.4541 mit Anschweißenden und Verspannung aus C-Stahl. Ab einer Anschweißendendicke von 3,5 mm ist das Anschweißende montagefertig gefast.
<b>Zulässige Betriebsdaten (Standard)</b>	16 barg / 120 °C gem. EJMA Höhere Drücke auf Anfrage.
<b>Zubehör</b>	Innenleitrohr
<b>Hinweis</b>	Bei Verwendung von Leitrohren vermindert sich der Balgquerschnitt. Bitte beachten Sie bei Ihrer Planung die Medienverträglichkeit der zu verwendenden Kompensatorenmaterialien.

## hinge

### Typ 234

### Type 235 (with internal sleeve)

<b>Application examples</b>	Steam plants, water, drainage, etc.
<b>Standard design</b>	Multi-layer corrugated tube bellows of 1.4541 with weld ends and gimbal hinge construction of carbon steel. From a weld end thickness of 3.5 mm, these parts are bevelled ready for installation.
<b>Permissible operating data</b>	16 barg / 120 °C acc. to EJMA Higher pressures on request.
<b>Accessories</b>	Internal sleeve
<b>Note</b>	Using internal sleeves will reduce the bellows cross-section. To be noted is that the media compatibility of the expansion joint material to be used should be taken into account in the planning phase.



**Typ 234 Abmessungen  
Ausführung 1**

**Type 234 Specifications  
Model 1**

**Druckstufe  
Design**

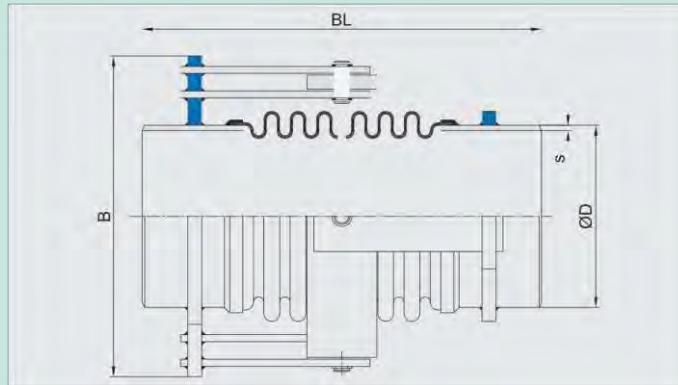

**2,5 barg (PN 2,5)  
pressure 2.5 barg (PN 2.5)**

DN	Länge Length	Größte Breite Biggest width	Anschweißenden Weld ends		Bewegungsaufnahme Movement angular	Verstellmomentrate Friction rate			Gewicht Weight	Artikel Article
	BL mm		B mm	ØD		s mm	mm	2αN %/deg.		
400	400	610	406,4	6,3	22	32,0	4,8	39,0	72,7	234-2,5-022-0400
400	475	610	406,4	6,3	32	19,0	8,0	39,0	76,7	234-2,5-032-0400
450	400	680	457,0	6,3	19	46,0	6,0	49,0	93,4	234-2,5-019-0450
450	475	680	457,0	6,3	29	28,0	10,0	49,0	97,7	234-2,5-029-0450
500	410	735	508,0	6,3	18	59,0	7,9	60,0	111,0	234-2,5-018-0500
500	510	735	508,0	6,3	28	36,0	15,0	60,0	116,0	234-2,5-028-0500
500	615	735	508,0	6,3	34	38,0	22,0	59,0	129,0	234-2,5-034-0500
600	420	850	610,0	6,0	14	151,0	12,0	86,0	147,0	234-2,5-014-0600
600	510	850	610,0	6,0	24	87,0	20,0	86,0	156,0	234-2,5-024-0600
600	630	850	610,0	6,0	32	55,0	32,0	86,0	161,0	234-2,5-032-0600
700	420	950	711,0	6,0	12	234,0	16,0	114,0	194,0	234-2,5-012-0700
700	510	950	711,0	6,0	20	129,0	27,0	114,0	200,0	234-2,5-020-0700
700	630	950	711,0	6,0	29	73,0	42,0	115,0	210,0	234-2,5-029-0700
800	400	1055	813,0	6,0	9	344,0	15,0	149,0	237,0	234-2,5-009-0800
800	490	1055	813,0	6,0	17	172,0	30,0	149,0	239,0	234-2,5-017-0800
800	640	1055	813,0	6,0	26	101,0	55,0	149,0	256,0	234-2,5-026-0800
900	410	1180	914,0	6,0	8	444,0	19,0	267,0	330,0	234-2,5-008-0900
900	500	1180	914,0	6,0	16	222,0	38,0	267,0	345,0	234-2,5-016-0900
900	620	1180	914,0	6,0	24	133,0	62,0	267,0	353,0	234-2,5-024-0900
1000	410	1285	1016,0	6,0	8	519,0	23,0	329,0	409,0	234-2,5-008-1000
1000	470	1285	1016,0	6,0	13	291,0	39,0	329,0	418,0	234-2,5-013-1000
1000	620	1285	1016,0	6,0	22	173,0	76,0	328,0	427,0	234-2,5-022-1000
1100	440	1390	1120,0	8,0	9	547,0	37,0	396,0	521,0	234-2,5-009-1100
1100	530	1390	1120,0	8,0	15	360,0	65,0	394,0	531,0	234-2,5-015-1100
1100	645	1390	1120,0	8,0	21	206,0	100,0	395,0	546,0	234-2,5-021-1100
1200	495	1455	1220,0	8,0	8	693,0	42,0	443,0	572,0	234-2,5-008-1200
1200	580	1455	1220,0	8,0	14	427,0	71,0	443,0	583,0	234-2,5-014-1200
1200	715	1455	1220,0	8,0	20	301,0	124,0	442,0	595,0	234-2,5-020-1200
1300	525	1565	1320,0	8,0	6	1090,0	37,0	830,0	734,0	234-2,5-006-1300
1300	545	1565	1320,0	8,0	9	753,0	61,0	830,0	728,0	234-2,5-009-1300
1300	700	1565	1320,0	8,0	16	388,0	108,0	828,0	759,0	234-2,5-016-1300
1400	545	1705	1420,0	8,0	9	934,0	71,0	959,0	897,0	234-2,5-009-1400
1400	640	1705	1420,0	8,0	15	481,0	124,0	958,0	912,0	234-2,5-015-1400
1500	525	1805	1520,0	8,0	8	1150,0	81,0	1098,0	1023,0	234-2,5-008-1500
1500	640	1805	1520,0	8,0	14	589,0	142,0	1097,0	1046,0	234-2,5-014-1500
1600	525	1900	1620,0	8,0	7	1380,0	92,0	1247,0	1135,0	234-2,5-007-1600
1600	640	1900	1620,0	8,0	13	711,0	162,0	1245,0	1159,0	234-2,5-013-1600

1700	720	2005	1720,0	8,0	12	879,0	182,0	1403,0	1400,0	<b>234-2,5-012-1700</b>
1800	820	2100	1820,0	8,0	12	1080,0	204,0	1569,0	1737,0	<b>234-2,5-012-1800</b>
1900	745	2225	1920,0	8,0	11	1320,0	231,0	1748,0	1964,0	<b>234-2,5-011-1900</b>
2000	765	2340	2020,0	8,0	10	1650,0	255,0	1933,0	2143,0	<b>234-2,5-010-2000</b>
2100	845	2440	2120,0	8,0	12	1420,0	281,0	2129,0	2433,0	<b>234-2,5-012-2100</b>
2200	890	2540	2220,0	8,0	11	1760,0	313,0	2332,0	2835,0	<b>234-2,5-011-2200</b>

Weitere Abmessungen und Werkstoffe auf Anfrage.  
/ Other dimensions and materials on request.

**Typ 234 Abmessungen  
Ausführung 1**

**Type 234 Specifications**

**Model 1**

**Druckstufe 6  
Design**

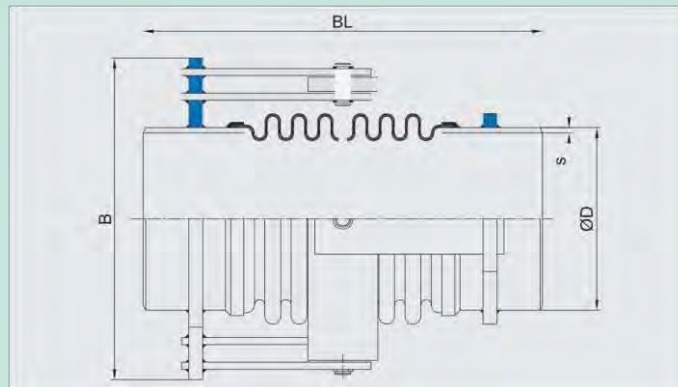

**barg (PN 6)  
pressure 6 barg (PN 6)**

DN	Länge Length		Größte Breite Biggest width		Anschweißenden Weld ends		Bewegungsaufnahme Movement angular		Verstellmomentrate Friction rate			Gewicht Weight kg	Artikel Article
	BL mm	B mm	ØD	s mm	mm	2αN °/deg.	Cλ N/mm	Cp N/mm barg	Cr N/barg				
50	355	190	60,3	2,9	48	0,8	0,1	0,4	7,9	234-06-048-0050			
50	455	190	60,3	2,9	50	0,7	0,2	0,4	8,9	234-06-050-0050			
65	345	205	76,1	2,9	40	1,1	0,2	0,6	9,7	234-06-040-0065			
65	410	205	76,1	2,9	50	1,1	0,3	0,6	10,5	234-06-050-0065			
80	305	235	88,9	3,2	31	1,9	0,2	0,9	10,2	234-06-031-0080			
80	350	235	88,9	3,2	44	1,1	0,3	0,9	10,7	234-06-044-0080			
100	315	265	114,3	3,6	30	1,9	0,3	1,5	14,2	234-06-030-0100			
100	355	265	114,3	3,6	44	2,1	0,4	1,5	14,8	234-06-044-0100			
125	325	290	139,7	4,0	25	3,1	0,4	3,6	21,7	234-06-025-0125			
125	375	290	139,7	4,0	41	2,8	0,7	3,5	23,1	234-06-041-0125			
150	335	325	168,3	4,5	24	5,0	0,6	5,1	27,4	234-06-024-0150			
150	420	325	168,3	4,5	39	8,0	1,3	5,1	30,4	234-06-039-0150			
200	360	380	219,1	6,3	23	6,3	1,2	12,0	48,5	234-06-023-0200			
200	445	380	219,1	6,3	36	9,8	2,3	12,0	52,4	234-06-036-0200			
250	350	440	273,0	6,3	17	15,0	1,8	18,0	48,9	234-06-017-0250			
250	435	440	273,0	6,3	31	18,0	3,5	18,0	53,0	234-06-031-0250			
300	390	495	323,9	7,1	19	24,0	2,5	25,0	67,1	234-06-019-0300			
300	435	495	323,9	7,1	25	17,0	3,7	25,0	68,6	234-06-025-0300			
300	495	495	323,9	7,1	35	26,0	5,3	25,0	74,4	234-06-035-0300			
350	390	530	355,6	6,3	17	33,0	2,9	29,0	68,0	234-06-017-0350			
350	435	530	355,6	6,3	24	19,0	4,5	30,0	71,7	234-06-024-0350			
350	530	530	355,6	6,3	33	32,0	7,5	30,0	81,2	234-06-033-0350			
400	430	625	406,4	6,3	17	42,0	5,5	39,0	104,0	234-06-017-0400			
400	495	625	406,4	6,3	26	33,0	8,4	39,0	111,0	234-06-026-0400			
400	635	625	406,4	6,3	35	61,0	15,0	38,0	129,0	234-06-035-0400			
450	425	685	457,0	6,3	14	91,0	6,2	49,0	126,0	234-06-014-0450			
450	480	685	457,0	6,3	20	50,0	9,1	49,0	130,0	234-06-020-0450			
450	600	685	457,0	6,3	33	66,0	16,0	49,0	146,0	234-06-033-0450			
500	435	740	508,0	6,3	13	110,0	8,4	60,0	154,0	234-06-013-0500			
500	530	740	508,0	6,3	20	64,0	15,0	60,0	160,0	234-06-020-0500			
500	630	740	508,0	6,3	32	87,0	22,0	60,0	183,0	234-06-032-0500			
600	475	850	610,0	6,0	12	214,0	15,0	84,0	211,0	234-06-012-0600			
600	540	850	610,0	6,0	22	120,0	21,0	86,0	223,0	234-06-022-0600			
600	640	850	610,0	6,0	29	123,0	31,0	85,0	244,0	234-06-029-0600			
700	560	945	711,0	6,0	18	209,0	28,0	114,0	300,0	234-06-018-0700			
700	675	945	711,0	6,0	26	186,0	45,0	113,0	320,0	234-06-026-0700			
800	550	1075	813,0	8,0	16	301,0	36,0	210,0	441,0	234-06-016-0800			
800	650	1075	813,0	8,0	22	214,0	53,0	211,0	469,0	234-06-022-0800			
900	560	1200	914,0	8,0	14	416,0	45,0	264,0	549,0	234-06-014-0900			
900	660	1200	914,0	8,0	22	307,0	66,0	265,0	582,0	234-06-022-0900			
1000	620	1305	1016,0	8,0	13	605,0	56,0	323,0	703,0	234-06-013-1000			

## Typ 234 Abmessungen Ausführung 1

## Type 234 Specifications

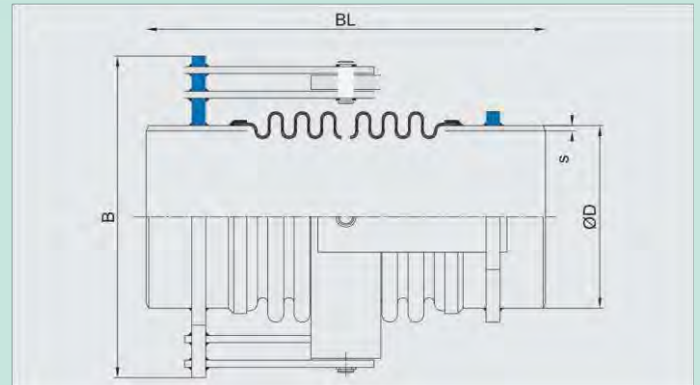

1000	700	1305	1016,0	8,0	21	355,0	81,0	326,0	722,0	234-06-021-1000
1100	675	1415	1120,0	8,0	12	869,0	78,0	626,0	936,0	234-06-012-1100
1100	840	1415	1120,0	8,0	19	508,0	99,0	635,0	1000,0	234-06-019-1100

Weitere Abmessungen und Werkstoffe auf Anfrage.  
/ Other dimensions and materials on request.

## Model 1

### Druckstufe 6 barg (PN 6)

### Design pressure 6 barg (PN 6)

DN	Länge Length	Größte Breite Biggest width	Anschweißenden Weld ends		Bewegungsaufnahme Movement angular	Verstellmomentrate Friction rate			Gewicht Weight kg	Artikel Article
	BL mm		B mm	ØD s mm		mm	Cλ N/mm	Cp N/mm barg		
1200	665	1495	1220	8,0	12	934,0	86,0	701,0	1005,0	234-06-012-1200
1200	745	1495	1220	8,0	19	560,0	120,0	707,0	1043,0	234-06-019-1200
1300	675	1600	1320	8,0	9	1680,0	65,0	832,0	1221,0	234-06-009-1300
1300	715	1600	1320	8,0	12	1330,0	105,0	828,0	1219,0	234-06-012-1300
1400	715	1720	1420	8,0	8	2080,0	75,0	962,0	1495,0	234-06-008-1400
1400	755	1720	1420	8,0	11	1640,0	121,0	958,0	1500,0	234-06-011-1400
1500	815	1840	1520	8,0	7	2630,0	86,0	1101,0	1822,0	234-06-007-1500
1500	875	1840	1520	8,0	11	2000,0	138,0	1097,0	1836,0	234-06-011-1500
1600	755	1965	1620	8,0	7	3430,0	97,0	1248,0	2123,0	234-06-007-1600
1600	815	1965	1620	8,0	10	2420,0	157,0	1246,0	2134,0	234-06-010-1600
1700	810	2065	1720	8,0	6	6200,0	113,0	1409,0	2491,0	234-06-006-1700
1700	840	2065	1720	8,0	9	4020,0	181,0	1408,0	2498,0	234-06-009-1700
1800	850	2170	1820	8,0	6	7050,0	126,0	1972,0	2927,0	234-06-006-1800
1800	910	2170	1820	8,0	9	4750,0	202,0	1970,0	2945,0	234-06-009-1800
1900	950	2270	1920	8,0	5	8260,0	141,0	2193,0	3393,0	234-06-005-1900
1900	1010	2270	1920	8,0	8	5570,0	225,0	2191,0	3416,0	234-06-008-1900
2000	910	2410	2020	8,0	5	9600,0	155,0	1941,0	3931,0	234-06-005-2000
2000	970	2410	2020	8,0	8	6470,0	249,0	1939,0	3957,0	234-06-008-2000
2100	950	2510	2120	8,0	5	11100,0	173,0	2671,0	4473,0	234-06-005-2100
2100	1030	2510	2120	8,0	9	5720,0	306,0	2674,0	4522,0	234-06-009-2100
2200	990	2615	2220	8,0	5	15800,0	194,0	2930,0	5077,0	234-06-005-2200
2200	1085	2615	2220	8,0	9	7140,0	304,0	2931,0	5163,0	234-06-009-2200

Weitere Abmessungen und Werkstoffe auf Anfrage. /  
Other dimensions and materials on request.

**Typ 234 Abmessungen  
Ausführung 1**

**Type 234 Specifications**

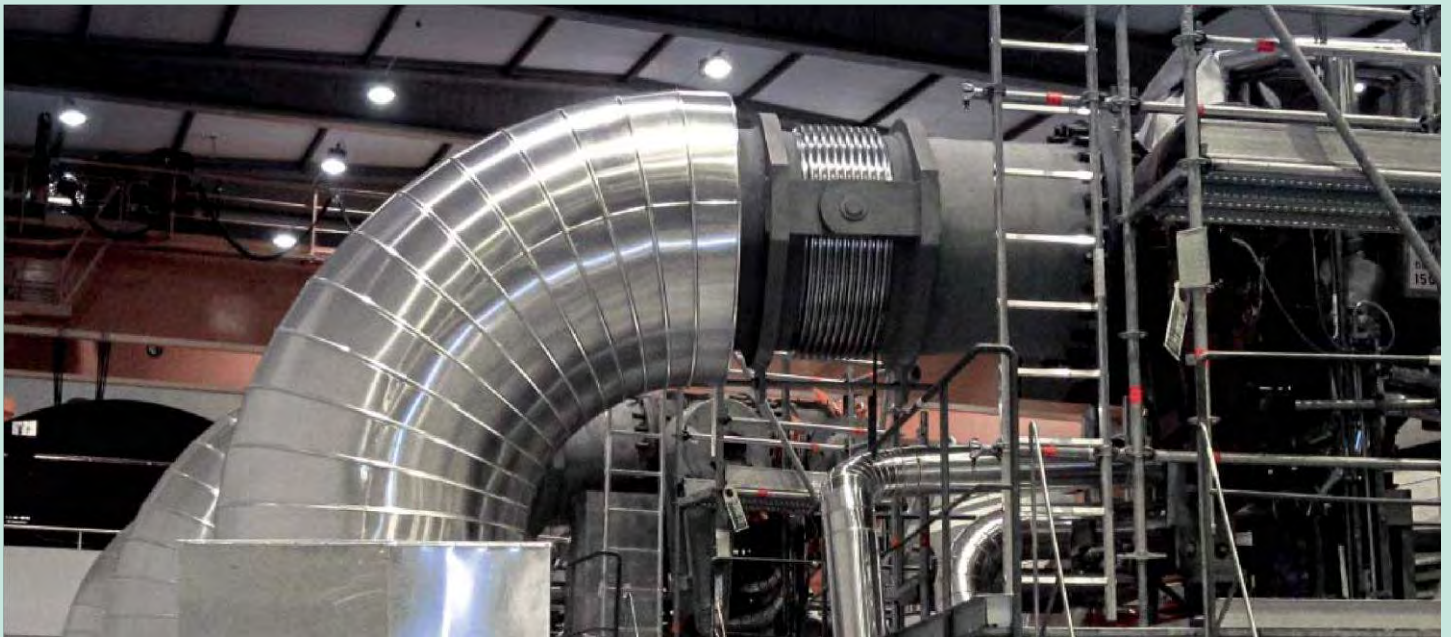
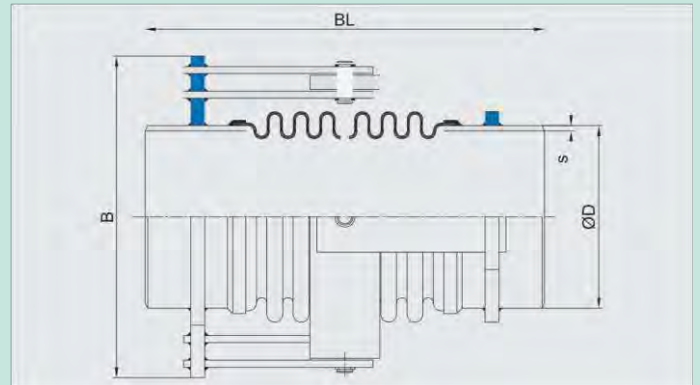

**Model 1**

**Druckstufe 10 barg (PN 10)**  
Design pressure 10 barg (PN 10)

## Typ 234 Abmessungen

### Ausführung 1

### Type 234 Specifications

DN	Länge Length	Größte Breite Biggest width	Anschweißenden Weld ends		Bewegungsaufnahme Movement	Verstellmomentrate Friction rate			Gewicht Weight	Artikel Article	
	BL mm	B mm	ØD	s mm	mm	angular	CA N/mm	Cp N/mm barg			Cr N/barg
					2αN %/deg.				kg		
50	335	190	60,3		2,9	38	0,9	0,1	0,4	7,8	234-10-038-0050
50	405	190	60,3		2,9	50	0,9	0,2	0,4	8,6	234-10-050-0050
65	335	205	76,1		2,9	32	1,4	0,2	0,6	9,7	234-10-032-0065
65	400	205	76,1		2,9	49	1,3	0,2	0,6	10,4	234-10-049-0065
80	310	235	88,9		3,2	26	2,1	0,2	0,9	10,3	234-10-026-0080
80	385	235	88,9		3,2	50	3,6	0,4	0,9	11,8	234-10-050-0080
100	320	265	114,3		3,6	28	3,4	0,3	1,5	14,6	234-10-028-0100
100	355	265	114,3		3,6	35	2,8	0,4	1,5	15,1	234-10-035-0100
125	325	290	139,7		4,0	21	3,4	0,4	3,5	21,4	234-10-021-0125
125	365	290	139,7		4,0	30	4,1	0,6	3,5	22,6	234-10-030-0125
150	320	325	168,3		4,5	19	11,0	0,5	5,1	27,9	234-10-019-0150
150	405	325	168,3		4,5	33	7,6	1,2	5,1	29,7	234-10-033-0150
200	350	380	219,1		6,3	18	25,0	1,2	12,0	50,0	234-10-018-0200
200	395	380	219,1		6,3	27	12,0	1,7	12,0	50,9	234-10-027-0200
200	460	380	219,1		6,3	36	17,0	2,4	12,0	56,6	234-10-036-0200
250	340	440	273,0		6,3	15	43,0	1,6	18,0	49,4	234-10-015-0250
250	385	440	273,0		6,3	23	21,0	2,5	18,0	51,3	234-10-023-0250
250	470	440	273,0		6,3	33	30,0	4,1	18,0	60,1	234-10-033-0250
300	420	495	323,9		7,1	14	52,0	2,3	25,0	81,1	234-10-014-0300
300	465	495	323,9		7,1	26	31,0	4,5	25,0	82,6	234-10-026-0300
300	535	495	323,9		7,1	28	46,0	6,4	25,0	92,9	234-10-028-0300
350	390	545	355,6		6,3	12	72,0	2,6	30,0	84,9	234-10-012-0350
350	440	545	355,6		6,3	23	38,0	4,3	30,0	91,8	234-10-023-0350
350	515	545	355,6		6,3	29	47,0	6,6	29,0	96,6	234-10-029-0350
400	400	630	406,4		6,3	13	104,0	3,5	39,0	129,0	234-10-013-0400
400	520	630	406,4		6,3	22	59,0	8,5	39,0	137,0	234-10-022-0400
400	585	630	406,4		6,3	29	85,0	12,0	38,0	151,0	234-10-029-0400
450	440	685	457,0		8,8	16	107,0	6,3	48,0	170,0	234-10-016-0450
450	505	685	457,0		8,8	23	93,0	9,9	49,0	180,0	234-10-023-0450
450	635	685	457,0		8,8	31	124,0	17,0	48,0	206,0	234-10-031-0450
500	400	740	508,0		8,8	9	270,0	5,2	59,0	203,0	234-10-009-0500
500	480	740	508,0		8,8	20	126,0	11,0	60,0	214,0	234-10-020-0500
500	595	740	508,0		8,8	27	131,0	18,0	60,0	230,0	234-10-027-0500
600	545	845	610,0		8,0	19	224,0	19,0	120,0	305,0	234-10-019-0600
600	705	845	610,0		8,0	23	237,0	35,0	121,0	344,0	234-10-023-0600
700	565	980	711,0		8,0	16	331,0	28,0	161,0	442,0	234-10-016-0700
700	680	980	711,0		8,0	24	296,0	43,0	163,0	471,0	234-10-024-0700
800	630	1095	813,0		8,0	15	483,0	43,0	211,0	584,0	234-10-015-0800
800	700	1095	813,0		8,0	20	360,0	55,0	213,0	611,0	234-10-020-0800
900	670	1200	914,0		8,0	13	790,0	42,0	427,0	781,0	234-10-013-0900
900	735	1200	914,0		8,0	19	508,0	76,0	425,0	786,0	234-10-019-0900
1000	590	1340	1016,0		8,0	11	1200,0	51,0	522,0	1017,0	234-10-011-1000
1000	755	1340	1016,0		8,0	17	678,0	93,0	521,0	1058,0	234-10-017-1000
1100	750	1455	1120,0		8,0	12	1580,0	75,0	635,0	1294,0	234-10-012-1100
1100	795	1455	1120,0		8,0	15	1230,0	94,0	635,0	1316,0	234-10-015-1100
1200	785	1525	1220,0		8,0	12	1670,0	83,0	713,0	1429,0	234-10-012-1200
1200	830	1525	1220,0		8,0	15	1400,0	106,0	715,0	1440,0	234-10-015-1200
1300	855	1645	1320,0		8,0	11	2090,0	97,0	1042,0	1824,0	234-10-011-1300
1300	880	1645	1320,0		8,0	14	1750,0	123,0	1044,0	1831,0	234-10-014-1300
1400	860	1770	1420,0		8,0	9	3260,0	95,0	1207,0	2283,0	234-10-009-1400
1400	920	1770	1420,0		8,0	13	2180,0	143,0	1207,0	2309,0	234-10-013-1400

**Typ 234 Abmessungen  
Ausführung 1**

**Type 234 Specifications**

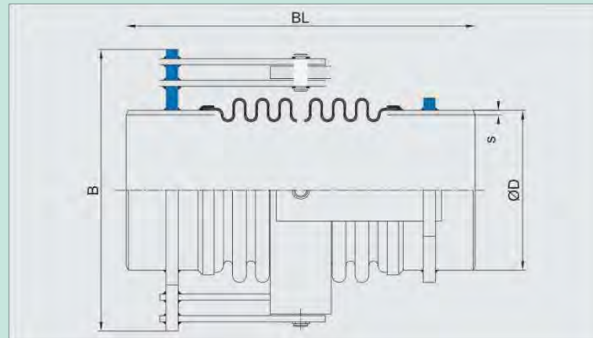

Weitere Abmessungen und Werkstoffe auf Anfrage.  
/ Other dimensions and materials on request.

**Model 1**

**Druckstufe 16 barg (PN 16)**

**Design pressure 16 barg (PN 16)**

DN	Länge Length	Größte Breite Biggest width	Anschweißenden Weld ends		Bewegungsaufnahme Movement angular	Verstellmomentrate Friction rate			Gewicht Weight	Artikel Article
			ØD	s mm		mm	2αN °/deg.	C <sub>A</sub> N/mm		
	BL mm	B mm								
50	335	190	60,3	2,9	34	0,9	0,1	0,4	7,8	234-16-034-0050
50	415	190	60,3	2,9	50	1,5	0,2	0,4	8,8	234-16-050-0050
65	335	205	76,1	2,9	28	1,4	0,2	0,6	9,7	234-16-028-0065
65	410	205	76,1	2,9	50	2,3	0,3	0,6	10,8	234-16-050-0065
80	310	235	88,9	3,2	22	2,1	0,2	0,9	10,3	234-16-022-0080
80	385	235	88,9	3,2	46	3,6	0,4	0,9	11,8	234-16-046-0080
100	320	265	114,3	3,6	24	3,4	0,3	1,5	14,6	234-16-024-0100
100	365	265	114,3	3,6	37	4,8	0,5	1,4	15,9	234-16-037-0100
125	315	290	139,7	4,0	15	9,0	0,4	3,5	21,7	234-16-015-0125
125	355	290	139,7	4,0	26	6,5	0,6	3,6	22,7	234-16-026-0125
125	390	290	139,7	4,0	32	7,5	0,7	3,5	24,7	234-16-032-0125
150	325	325	168,3	4,5	16	19,0	0,6	5,1	28,4	234-16-016-0150
150	355	325	168,3	4,5	23	9,9	0,8	5,2	28,7	234-16-023-0150
150	415	325	168,3	4,5	35	14,0	1,2	5,0	32,3	234-16-035-0150
200	335	380	219,1	6,3	16	32,0	0,9	12,0	50,5	234-16-016-0200
200	400	380	219,1	6,3	25	18,0	1,7	12,0	53,1	234-16-025-0200
200	490	380	219,1	6,3	33	32,0	2,8	12,0	60,6	234-16-033-0200
250	375	465	273,0	6,3	14	47,0	1,9	18,0	83,6	234-16-014-0250
250	410	465	273,0	6,3	21	33,0	2,6	18,0	87,2	234-16-021-0250
250	520	465	273,0	6,3	28	53,0	4,6	18,0	98,1	234-16-028-0250
300	385	530	323,9	7,1	10	105,0	1,8	25,0	131,0	234-16-010-0300
300	440	530	323,9	7,1	20	54,0	3,3	25,0	137,0	234-16-020-0300
300	540	530	323,9	7,1	26	63,0	6,0	25,0	144,0	234-16-026-0300
350	415	565	355,6	8,0	11	116,0	2,8	29,0	118,0	234-16-011-0350
350	450	565	355,6	8,0	18	75,0	3,9	30,0	125,0	234-16-018-0350
350	545	565	355,6	8,0	25	77,0	6,9	29,0	139,0	234-16-025-0350
400	510	620	406,4	8,8	18	108,0	7,2	55,0	174,0	234-16-018-0400
400	535	620	406,4	8,8	22	92,0	8,4	55,0	182,0	234-16-022-0400
450	520	715	457,0	8,8	16	158,0	9,0	48,0	236,0	234-16-016-0450
450	545	715	457,0	8,8	20	127,0	11,0	48,0	244,0	234-16-020-0450

## Typ 234 Abmessungen Ausführung 1

## Type 234 Specifications

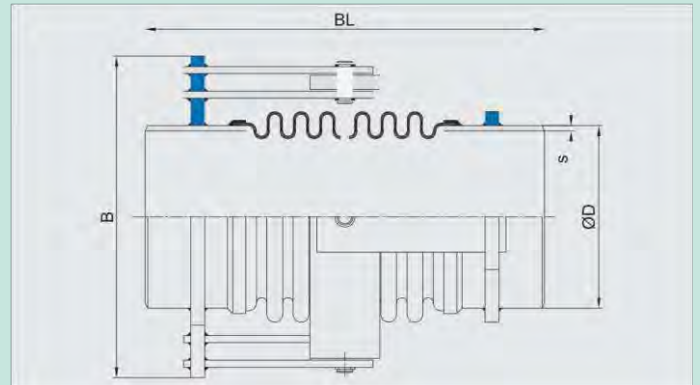

500	540	735	508,0	8,8	14	246,0	13,0	84,0	265,0	234-16-014-0500
500	570	735	508,0	8,8	20	172,0	15,0	85,0	275,0	234-16-020-0500
600	550	880	610,0	8,0	12	593,0	16,0	121,0	423,0	234-16-012-0600
600	685	880	610,0	8,0	18	330,0	29,0	121,0	441,0	234-16-018-0600
700	610	990	711,0	8,0	11	983,0	22,0	263,0	602,0	234-16-011-0700
700	655	990	711,0	8,0	16	614,0	35,0	263,0	610,0	234-16-016-0700
800	645	1115	813,0	8,0	11	1230,0	34,0	339,0	795,0	234-16-011-0800
800	745	1115	813,0	8,0	16	839,0	57,0	338,0	814,0	234-16-016-0800
900	690	1250	914,0	8,0	10	2110,0	44,0	427,0	1123,0	234-16-010-0900
900	750	1250	914,0	8,0	16	1090,0	73,0	429,0	1146,0	234-16-016-0900
1000	790	1370	1016,0	8,0	9	2830,0	54,0	654,0	1515,0	234-16-009-1000
1000	850	1370	1016,0	8,0	14	1510,0	89,0	656,0	1543,0	234-16-014-1000

Weitere Abmessungen und Werkstoffe auf Anfrage. /  
Other dimensions and materials on request.

## Model 1

### Druckstufe 25 barg (PN 25)

### Design pressure 25 barg (PN 25)

DN	Länge Length	Größte Breite Biggest width	Anschweißenden Weld ends			Bewegungsaufnahme Movement angular	Verstellmomentrate Friction rate			Gewicht Weight	Artikel Article
			ØD	s mm	mm		CA N/mm	Cp N/mm barg	Cr N/barg		
50	325	190	60,3	4,0	27	1,0	0,1	0,4	8,1	234-25-027-0050	
50	380	190	60,3	4,0	44	1,9	0,2	0,4	8,7	234-25-044-0050	
65	335	205	76,1	4,0	24	1,8	0,2	0,5	10,1	234-25-024-0065	
65	425	205	76,1	4,0	43	3,5	0,3	0,5	11,6	234-25-043-0065	
80	310	235	88,9	4,0	23	3,2	0,2	0,9	10,9	234-25-023-0080	
80	360	235	88,9	4,0	36	4,4	0,3	0,9	12,0	234-25-036-0080	
100	310	265	114,3	4,0	21	6,0	0,3	1,5	15,1	234-25-021-0100	
100	365	265	114,3	4,0	30	6,6	0,5	1,4	15,7	234-25-030-0100	
125	345	290	139,7	4,0	19	9,5	0,5	3,5	23,0	234-25-019-0125	
125	385	290	139,7	4,0	28	12,0	0,7	3,4	25,5	234-25-028-0125	
150	335	325	168,3	4,5	16	24,0	0,6	5,1	29,5	234-25-016-0150	
150	410	325	168,3	4,5	27	19,0	1,2	5,0	32,6	234-25-027-0150	
200	350	380	219,1	6,3	14	53,0	0,9	12,0	52,2	234-25-014-0200	



## Typ 234 Abmessungen Ausführung 1

## Type 234 Specifications

200	400	380	219,1	6,3	22	26,0	1,6	12,0	55,2	234-25-022-0200
250	370	465	273,0	7,1	10	117,0	1,4	18,0	87,1	234-25-010-0250
250	425	465	273,0	7,1	17	58,0	2,4	18,0	91,4	234-25-017-0250
250	485	465	273,0	7,1	22	60,0	3,6	18,0	97,1	234-25-022-0250
300	430	530	323,9	8,0	11	148,0	2,4	24,0	138,0	234-25-011-0300
300	480	530	323,9	8,0	15	93,0	3,7	24,0	142,0	234-25-015-0300
300	505	530	323,9	8,0	19	79,0	4,5	25,0	148,0	234-25-019-0300
350	490	560	355,6	8,0	14	129,0	4,5	41,0	160,0	234-25-014-0350
350	515	560	355,6	8,0	18	108,0	5,3	42,0	167,0	234-25-018-0350
400	495	625	406,4	8,8	13	237,0	5,7	54,0	214,0	234-25-013-0400
400	590	625	406,4	8,8	19	160,0	9,7	55,0	230,0	234-25-019-0400
450	515	705	457,0	8,8	11	382,0	7,2	110,0	314,0	234-25-011-0450
450	610	705	457,0	8,8	17	243,0	13,0	112,0	335,0	234-25-017-0450
500	555	775	508,0	8,8	12	573,0	12,0	85,0	379,0	234-25-012-0500
500	640	775	508,0	8,8	16	345,0	18,0	85,0	393,0	234-25-016-0500
600	600	890	610,0	10,0	10	1200,0	18,0	196,0	580,0	234-25-010-0600
600	705	890	610,0	10,0	15	685,0	28,0	196,0	605,0	234-25-015-0600
700	645	1045	711,0	10,0	8	2490,0	24,0	262,0	889,0	234-25-008-0700
700	710	1045	711,0	10,0	14	1040,0	38,0	266,0	920,0	234-25-014-0700

Weitere Abmessungen und Werkstoffe auf Anfrage.  
/ Other dimensions and materials on request.



**Typ 234 Abmessungen  
Ausführung 1**

**Type 234 Specificaions**

**Model 1**

**Druckstufe 40 barg (PN 40)  
Design pressure 40 barg (PN 40)**

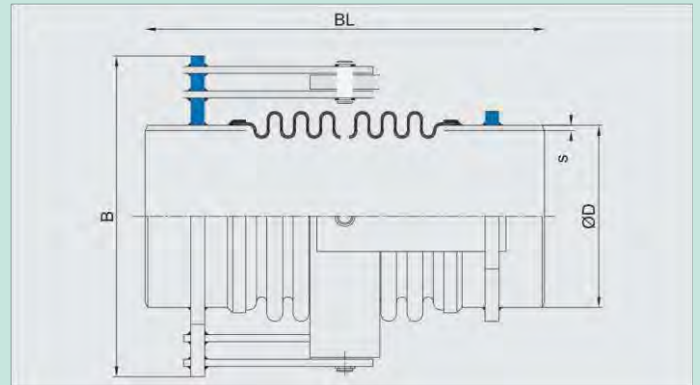

DN	Länge	Größte Breite Biggest width	Anschweißenden Weld ends		Bewegungsaufnahme Movement angular	Verstellmomentrate Friction rate			Gewicht Weight	Artikel Article
	Length		B	ØD		s	mm	CA		
	BL	B	mm	mm	2αN	N/mm	N/mm barg	N/barg	kg	
50	320	190	60,3	4,0	26	1,9	0,1	0,4	8,1	234-40-026-0050
50	360	190	60,3	4,0	32	2,5	0,1	0,4	8,6	234-40-032-0050
65	335	205	76,1	4,0	25	2,9	0,2	0,5	10,1	234-40-025-0065
65	385	205	76,1	4,0	35	4,9	0,2	0,6	11,0	234-40-035-0065
80	345	235	88,9	4,0	21	5,6	0,2	1,5	18,8	234-40-021-0080
80	390	235	88,9	4,0	29	8,0	0,3	1,6	20,3	234-40-029-0080
100	365	265	114,3	4,0	17	9,2	0,4	2,3	23,5	234-40-017-0100
100	415	265	114,3	4,0	24	14,0	0,5	2,5	25,3	234-40-024-0100
125	380	320	139,7	4,0	17	17,0	0,5	3,4	41,3	234-40-017-0125
125	425	320	139,7	4,0	21	19,0	0,7	3,6	43,3	234-40-021-0125
150	405	355	168,3	4,5	18	30,0	0,8	6,8	63,2	234-40-018-0150
150	470	355	168,3	4,5	22	35,0	1,4	7,3	67,2	234-40-022-0150
200	450	415	219,1	6,3	17	68,0	1,6	16,0	109,0	234-40-017-0200
200	485	415	219,1	6,3	19	58,0	2,3	17,0	112,0	234-40-019-0200
250	470	510	273,0	7,1	14	113,0	2,5	25,0	190,0	234-40-014-0250
250	555	510	273,0	7,1	18	108,0	4,0	26,0	201,0	234-40-018-0250
300	555	580	323,9	8,0	13	200,0	3,6	35,0	283,0	234-40-013-0300
300	635	580	323,9	8,0	16	155,0	6,0	36,0	294,0	234-40-016-0300
350	495	600	355,6	8,0	8	441,0	3,1	41,0	233,0	234-40-008-0350

## Typ 234 Abmessungen Ausführung 1

## Type 234 Specifications

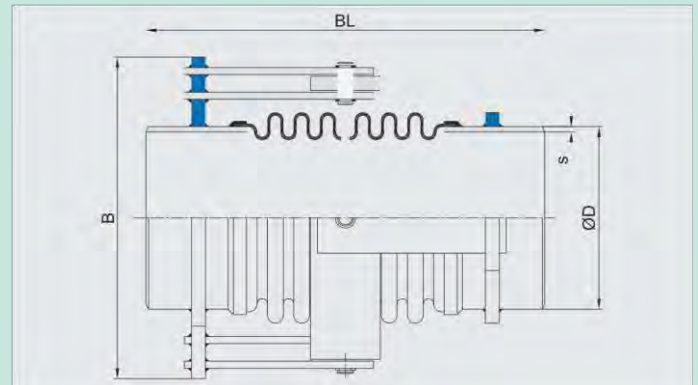

350	595	600	355,6	8,0	14	235,0	6,4	43,0	251,0	234-40-014-0350
400	520	670	406,4	10,0	9	604,0	5,0	54,0	327,0	234-40-009-0400
400	620	670	406,4	10,0	13	448,0	9,4	55,0	343,0	234-40-013-0400
450	535	745	457,0	10,0	6	1290,0	5,1	109,0	452,0	234-40-006-0450
450	660	745	457,0	10,0	13	523,0	13,0	110,0	480,0	234-40-013-0450
500	610	780	508,0	10,0	6	1660,0	6,8	137,0	527,0	234-40-006-0500
500	665	780	508,0	10,0	12	699,0	15,0	137,0	542,0	234-40-012-0500

Weitere Abmessungen und Werkstoffe auf Anfrage. /  
Other dimensions and materials on request.

## Model 1

### Druckstufe 63 barg (PN 63)

### Design pressure 63 barg (PN 63)

DN	Länge Length		Größte Breite Biggest width		Anschweißenden Weld ends		Bewegungsaufnahme Movement angular	Verstellmomentrate Friction rate			Gewicht Weight kg	Artikel Article
	BL mm	B mm	ØD	s mm	mm	2αN °/deg.		Cλ N/mm	Cp N/mm barg	Cr N/barg		
50	305	190	60,3	4,0	13	6,4	0,1	0,4	8,1	234-63-013-0050		
50	345	190	60,3	4,0	20	4,1	0,1	0,4	8,5	234-63-020-0050		
65	315	205	76,1	4,0	13	9,7	0,1	0,5	10,3	234-63-013-0065		
65	365	205	76,1	4,0	18	8,2	0,2	0,6	10,6	234-63-018-0065		

**Typ 234 Abmessungen  
Ausführung 1**

**Type 234 Specifications**

80	335	235	88,9	4,0	13	15,0	0,2	1,4	18,8	<b>234-63-013-0080</b>
80	375	235	88,9	4,0	18	9,6	0,3	1,6	19,4	<b>234-63-018-0080</b>
100	343	265	114,3	5,0	8	37,0	0,2	2,3	24,3	<b>234-63-008-0100</b>
100	390	265	114,3	5,0	14	20,0	0,4	2,4	25,0	<b>234-63-014-0100</b>
125	365	320	139,7	6,3	9	54,0	0,3	3,4	43,7	<b>234-63-009-0125</b>
125	445	320	139,7	6,3	16	29,0	0,7	3,6	46,1	<b>234-63-016-0125</b>
150	385	355	168,3	6,3	9	135,0	0,6	6,5	64,3	<b>234-63-009-0150</b>
150	450	355	168,3	6,3	16	53,0	1,2	7,2	68,0	<b>234-63-016-0150</b>
200	400	415	219,1	8,0	7	237,0	0,8	16,0	109,0	<b>234-63-007-0200</b>
200	490	415	219,1	8,0	13	142,0	1,9	17,0	118,0	<b>234-63-013-0200</b>
250	460	510	273,0	10,0	7	460,0	1,6	25,0	197,0	<b>234-63-007-0250</b>
250	545	510	273,0	10,0	12	254,0	3,3	26,0	207,0	<b>234-63-012-0250</b>
300	525	580	323,9	11,0	6	872,0	2,3	34,0	294,0	<b>234-63-006-0300</b>
300	655	580	323,9	11,0	12	438,0	6,0	36,0	311,0	<b>234-63-012-0300</b>
350	545	620	355,6	12,5	7	853,0	3,3	65,0	358,0	<b>234-63-007-0350</b>
350	630	620	355,6	12,5	12	485,0	6,4	69,0	379,0	<b>234-63-012-0350</b>
400	570	675	406,4	14,2	6	1830,0	4,6	86,0	463,0	<b>234-63-006-0400</b>
400	650	675	406,4	14,2	10	1130,0	8,4	90,0	485,0	<b>234-63-010-0400</b>

Weitere Abmessungen und Werkstoffe auf Anfrage.  
/ Other dimensions and materials on request.

## Angularkompensator mit Festflanschen und Kardangeln

Typ 236

Typ 237 (mit Innenleitrohr)

## Angular expansion joint with fixed flanges and gimbal hinge

Type 236

Type 237 (with internal sleeve)

Der Typ 236 ist ein mehrlagiger Angularkompensator mit Festflanschen

mit Kardangeln und allseitig beweglich. Die Verspannung ist auf die Anschlüsse aufgeschweißt.

Er ist speziell konzipiert für den Betrieb in Anlagen mit Betriebsdrücken bis 25 barg.

Dieser Kompensator lässt allseitige angulare Bewegungen zu.

### Beschreibung

Neben den aufgeführten Standardbaulängen kann die Baulänge speziell auf Ihre Bedürfnisse angepasst gefertigt werden. Dieser Kompensator kann auch in anderen Werkstoffen (siehe Seite 179) gefertigt werden.



Type 236 is a multi-layer angular expansion joint with fixed flanges and gimbal hinge and moveable in all directions. This expansion joint has a gimbal hinge construction.

It is designed specifically for operation in installations with operating pressures up to 25 barg.

This expansion joint allows angular movements in all plains.

### Description

In addition to the given standard lengths, other lengths are available to meet specific requirements. This expansion joint can also be produced in other materials (see page 179).

<b>Einsatzbeispiele</b>	Dampfanlagen, Entwässerung	<b>Application examples</b>	Steam plants, water, drainage, etc.
<b>Standardmäßiger Aufbau</b>	Mehrlagiger We 1.4541 mit Ansc Verspannung an	<b>Standard design</b>	Multi-layer corrugated tube bellows of 1.4541 with weld ends and gimbal hinge construction of carbon steel.
<b>Zulässige Betriebsdaten (Standard)</b>	16 barg / 120 °C Höhere Drücke	<b>Permissible operating data</b>	16 barg / 120 °C acc. to EJMA Higher pressures on request.
<b>Hinweis</b>	Bei Verwendung vermindert sich Bitte beachten S die Medienverträ verwendenden Kompensatoren	<b>Note</b>	Using internal sleeves will reduce the bellows cross-section. To be noted is that the media compatibility of the expansion joint material to be used should be taken into account in the planning phase.

**Typ 236 Abmessungen  
Ausführung 1**

**Type 236 Specifications**

**Model 1**

**Druckstufe 6 barg (PN 6)  
Design pressure 6 barg (PN 6)**

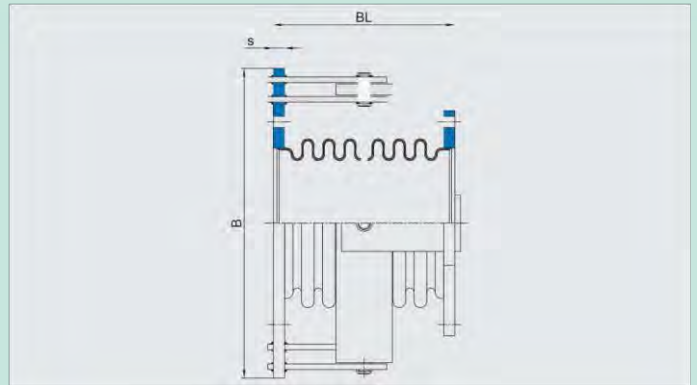

	Länge Length		Größte Breite Biggest width		Flansch Flanges		Bewegungsaufnahme Movement angular		Verstellkräfte Springrate			Gewicht Weight kg	Artikel Article
	BL mm	B mm	s mm	2αN °/deg.	Cα N/mm	Cp N/mm barg	Cr N/barg						
50	150	260	17	48	0,8	0,1	0,4	10,1	236-06-048-0050				
50	245	260	17	50	0,7	0,2	0,4	11,0	236-06-050-0050				
65	140	280	17	40	1,1	0,2	0,6	11,4	236-06-040-0065				
65	205	280	17	50	1,1	0,3	0,6	12,3	236-06-050-0065				
80	125	295	17	31	1,9	0,2	0,9	14,2	236-06-031-0080				
80	170	295	17	43	1,1	0,3	0,9	14,7	236-06-043-0080				
100	135	330	17	30	1,9	0,3	1,5	16,4	236-06-030-0100				
100	175	330	17	44	2,1	0,4	1,5	17,2	236-06-044-0100				
125	135	365	17	25	3,1	0,4	2,3	20,1	236-06-025-0125				
125	185	365	17	41	2,8	0,7	2,1	21,0	236-06-041-0125				
150	150	395	17	24	5,0	0,6	5,1	23,3	236-06-024-0150				
150	230	395	17	39	8,0	1,3	5,1	26,1	236-06-039-0150				
200	170	435	22	21	6,3	1,3	8,4	34,4	236-06-021-0200				
200	250	435	22	36	9,8	2,3	8,4	38,5	236-06-036-0200				
250	165	520	22	17	15,0	1,8	13,0	47,8	236-06-017-0250				
250	250	520	22	31	18,0	3,4	13,0	53,2	236-06-031-0250				
300	275	585	22	32	26,0	5,3	25,0	85,3	236-06-032-0300				
350	320	595	27	34	32,0	7,4	30,0	84,2	236-06-034-0350				

## Typ 236 Abmessungen Ausführung 1

## Type 236 Specifications

400	290	670	27	26	33,0	8,4	39,0	105,0	236-06-026-0400
450	265	730	27	19	50,0	9,1	70,0	125,0	236-06-019-0450
500	330	780	27	20	64,0	15,0	60,0	138,0	236-06-020-0500
600	360	895	37	21	120,0	21,0	86,0	211,0	236-06-021-0600
700	500	1005	37	26	186,0	45,0	113,0	300,0	236-06-026-0700
800	505	1120	42	21	214,0	58,0	211,0	405,0	236-06-021-0800

Weitere Abmessungen und Werkstoffe auf Anfrage.  
/ Other dimensions and materials on request.



**Typ 236 Abmessungen**  
**Ausführung 1**

**Type 236 Specifications**

**Model 1**

**Druckstufe 10 barg (PN 10)**  
**Design pressure 10 barg (PN 10)**

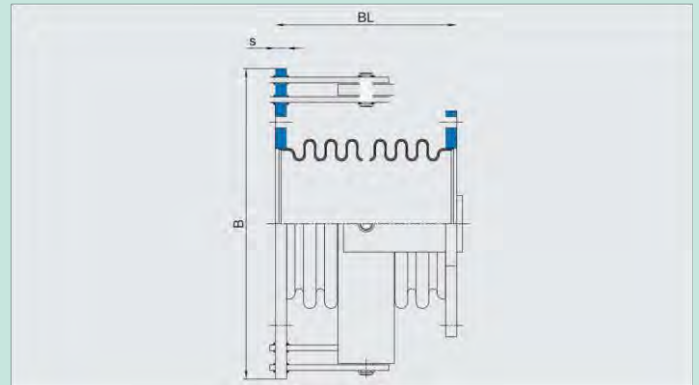

DN	Länge Length		Größte Breite Biggest width		Flansch Flanges		Bewegungsaufnahme Movement angular		Verstellkräfte Springrate			Gewicht Weight kg	Artikel Article
	BL mm	B mm	s mm	2αN °/deg.	Cα N/mm	Cp N/mm barg	Cr N/barg						
50	140	260	22	32	0,9	0,1	0,4	13,1	236-10-032-0050				
50	205	260	22	50	0,9	0,2	0,4	13,9	236-10-050-0050				
65	140	280	22	31	1,4	0,2	0,6	14,7	236-10-031-0065				
65	205	280	22	49	1,3	0,2	0,6	15,5	236-10-049-0065				
80	135	295	22	26	2,1	0,2	0,9	17,1	236-10-026-0080				
80	215	295	22	50	3,6	0,4	0,9	18,7	236-10-050-0080				
100	140	330	22	28	3,4	0,3	1,5	19,8	236-10-028-0100				
100	175	330	22	35	2,8	0,4	1,5	20,5	236-10-035-0100				
125	175	365	22	30	4,1	0,6	2,1	25,0	236-10-030-0125				



## Typ 236 Abmessungen Ausführung 1

### Type 236 Specifications

125	255	365	22	42	7,0	1,0	2,1	27,6	236-10-042-0125
150	140	395	22	19	11,0	0,5	5,1	29,2	236-10-019-0150
150	220	395	22	33	7,6	1,2	5,1	31,5	236-10-033-0150
200	205	435	22	25	12,0	1,7	8,4	39,5	236-10-025-0200
200	275	435	22	38	17,0	2,5	8,2	44,1	236-10-038-0200
250	215	520	27	23	21,0	2,5	13,0	60,2	236-10-023-0250
250	300	520	27	33	30,0	4,0	13,0	68,2	236-10-033-0250
300	255	585	27	26	31,0	4,5	25,0	91,3	236-10-026-0300
350	300	610	27	24	47,0	6,7	29,0	99,8	236-10-024-0350
400	385	695	32	29	85,0	12,0	38,0	150,0	236-10-029-0400
450	305	750	37	17	93,0	9,9	69,0	188,0	236-10-017-0450
500	415	805	37	26	131,0	19,0	60,0	217,0	236-10-026-0500
600	350	955	43	18	224,0	18,0	120,0	335,0	236-10-018-0600

Weitere Abmessungen und Werkstoffe auf Anfrage.  
/ Other dimensions and materials on request.

**Typ 236 Abmessungen**  
**Ausführung 1**

**Type 236 Specifications**

**Model 1**

**Druckstufe 16 barg (PN 16)**  
**Design pressure 16 barg (PN 16)**

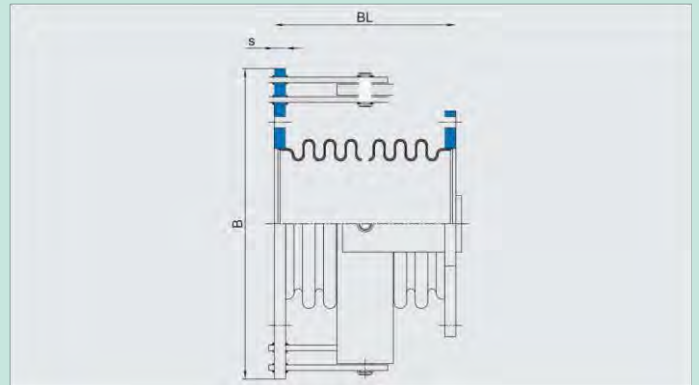

DN	Länge	Größte Breite		Flansch	Bewegungsaufnahme	Verstellkräfte			Gewicht	Artikel
	Length	Biggest width				Flanges	Movement	Springrate		
	BL	B	B	s	angular	C $\alpha$	C $p$	C $r$	kg	
	mm	mm	mm	mm	2 $\alpha$ N	N/mm	N/mm barg	N/barg		
					%deg.					
50	140		260	22	32	0,9	0,1	0,4	13,1	236-16-032-0050
50	215		260	22	50	1,5	0,2	0,4	14,1	236-16-050-0050
65	140		280	22	27	1,4	0,2	0,6	14,7	236-16-027-0065
65	215		280	22	50	2,3	0,3	0,6	16,1	236-16-050-0065
80	135		295	22	23	2,1	0,2	0,9	17,1	236-16-023-0080
80	215		295	22	46	3,6	0,4	0,9	18,7	236-16-046-0080
100	140		330	22	24	3,4	0,3	1,5	19,8	236-16-024-0100
100	190		330	22	37	4,8	0,5	1,4	21,1	236-16-037-0100
125	165		365	22	26	6,5	0,6	2,3	25,5	236-16-026-0125
125	200		365	22	32	7,5	0,7	2,1	27,2	236-16-032-0125
150	175		395	22	23	9,9	0,8	5,2	32,7	236-16-023-0150
150	240		395	22	35	14,0	1,3	5,0	36,2	236-16-035-0150
200	225		435	27	25	18,0	1,8	8,4	45,5	236-16-025-0200
200	315		435	27	33	32,0	2,8	8,1	52,5	236-16-033-0200
250	215		560	32	14	47,0	2,1	18,0	95,4	236-16-014-0250
250	245		560	32	21	33,0	2,8	18,0	99,6	236-16-021-0250
300	325		585	32	26	63,0	6,0	25,0	114,0	236-16-026-0300
350	245		660	37	18	75,0	4,3	30,0	145,0	236-16-018-0350

## Typ 236 Abmessungen Ausführung 1

Weitere Abmessungen  
und Werkstoffe auf  
Anfrage. / Other  
dimensions and materials  
on request.

## Type 236 Specifications

Druckstufe 25 barg (PN 25)  
Design pressure 25 barg (PN 25)

DN	Länge Length	Größte Breite Biggest width		Flansch Flanges	Bewegungsaufnahme Movement angular	/erstellkraft Springrate			Gewicht Weight	Artikel Article	
	BL mm	B mm		s mm	2αN °/deg.	Cα N/mm	Cp N/mm barg	Cr N/barg	kg		
50	130		260		22	27	1,0	0,1	0,4	13,0	236-25-027-0050
50	185		260		22	43	1,9	0,2	0,4	13,6	236-25-043-0050
65	135		280		22	24	1,8	0,2	0,5	14,7	236-25-024-0065
65	230		280		22	43	3,5	0,3	0,5	16,2	236-25-043-0065
80	140		295		22	23	3,2	0,2	0,9	17,4	236-25-023-0080
80	190		295		22	36	4,4	0,3	0,9	18,5	236-25-036-0080
100	130		330		22	21	6,0	0,3	1,5	21,2	236-25-021-0100
100	190		330		22	30	6,6	0,5	1,4	22,3	236-25-030-0100
125	155		365		22	19	9,5	0,5	2,1	26,9	236-25-019-0125
125	200		365		22	28	12,0	0,7	2,1	29,3	236-25-028-0125
150	170		395		27	16	24,0	0,6	5,1	38,6	236-25-016-0150
150	235		395		27	27	19,0	1,2	5,0	41,0	236-25-027-0150
200	225		485		32	18	26,0	1,6	12,0	75,1	236-25-018-0200
250	305		560		37	22	60,0	3,5	18,0	119,0	236-25-022-0250
300	290		650		43	19	79,0	4,5	25,0	174,0	236-25-019-0300
350	305		690		42	17	108,0	6,0	29,0	195,0	236-25-017-0350

Weitere Abmessungen und Werkstoffe auf Anfrage.  
/ Other dimensions and materials on  
request.

## Angularkompensator mit Losflanschen und einfacher Gelenkverspannung

Der Typ 238 ist ein mehrlagiger Angularkompensator mit Losflanschen, einseitig beweglich. Der Kompensator besitzt eine einfache Angularverspannung.

Er ist speziell konzipiert für den Betrieb in Anlagen mit Betriebsdrücken bis 25 barg

Dieser Kompensator lässt angulare Bewegungen zu.

Durch Hintereinanderschaltung zweier Kompensatoren lassen sich auch große laterale Bewegungen realisieren.

### Beschreibung

Neben den aufgeführten Standardbaulängen kann die Baulänge speziell auf Ihre Bedürfnisse angepasst gefertigt werden. Dieser Kompensator kann auch in anderen Werkstoffen (siehe Seite 179) gefertigt werden.

### Anforderungen

- Strömungsumlenkung/Umlenkung des Rohrleitungssystems erforderlich
- Höherer Platzbedarf als Axialkompensatoren
- Für ein System sind zwei oder drei Kompensatoren erforderlich

## Typ 238 Angular expansion joint with loose flanges and single hinge construction Type 238



Type 238 is a multi-layer angular expansion joint with loose flanges and moveable in one direction. This expansion joint has a hinge construction.

It is designed specifically for operation in installations with operating pressures up to 25 barg.

This expansion joint allows angular movements.

Two expansion joints can be arranged in tandem to also allow large lateral movements.

### Description

In addition to the given standard lengths, other lengths are available to meet specific requirements. This expansion joint can also be produced in other materials (see page 179).

### Requirements

- Flow deflection/redirection of pipe system necessary
- More space required than for axial expansion joints
- Two or three expansion joints required for one system

**Typ 238 Abmessungen  
Ausführung 1**

**Type 238 Specifications  
Angularkompensator**

**Angular expansion mit Losflanschen joint with loose flanges**

**Typ 238**

**Type 238**

<b>Einsatzbeispiele</b>	U- und Z-Rohrleitungssysteme
<b>Standardmäßiger Aufbau</b>	Mehrlagiger Wellrohrbalg aus 1.4541 mit Losflanschen und Verspannung aus C-Stahl
<b>Zulässige Betriebsdaten (Standard)</b>	16 barg / 120 °C gem. EJMA Höhere Drücke auf Anfrage.
<b>Zubehör</b>	Innenleitrohr auf Anfrage.
<b>Hinweis</b>	Bei Verwendung von Leitrohren vermindert sich der Balgquerschnitt. Bitte beachten Sie bei Ihrer Planung die Medienverträglichkeit der zu verwendenden Kompensatorenmaterialien.

<b>Application examples</b>	U and Z piping systems
<b>Standard design</b>	Multi-layer corrugated tube bellows of 1.4541 with loose flanges and hinge construction of carbon steel.
<b>Permissible operating data</b>	16 barg / 120 °C acc. to EJMA Higher pressures on request.
<b>Accessories</b>	Internal sleeve on request.
<b>Note</b>	Using internal sleeves will reduce the bellows cross-section. To be noted is that the media compatibility of the expansion joint material to be used should

**Typ 238 Abmessungen  
Ausführung 1**

**Type 238 Specifications  
Model 1**

**Druckstufe 6 barg  
Design pressure 6**

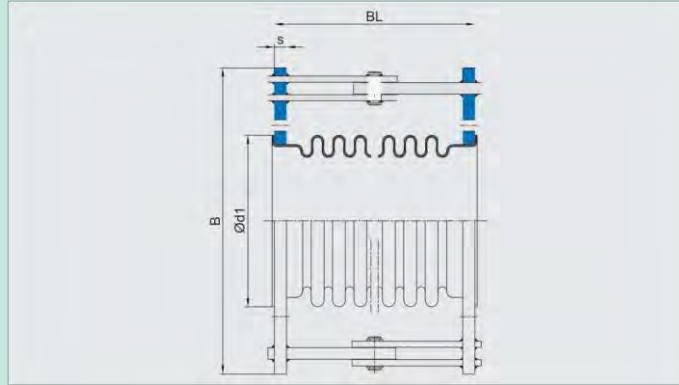

**(PN 6)  
barg (PN 6)**

DN	Länge Length	Größte Breite Biggest width	Flansch Flan <sup>g</sup> es		Bewegungsaufnahme Movement angular	Verstellmomentrate Friction rate			Gewicht Weight	Artikel Article
	BL mm		B mm	Ød1 mm		s mm	2αN %/deg.	Cα N/mm		
50	155	260	90	17	49	0,8	0,1	0,4	7,7	238-06-049-0050
50	255	260	90	17	50	0,7	0,2	0,4	8,8	238-06-050-0050
65	145	280	107	17	40	1,1	0,2	0,6	8,7	238-06-040-0065
65	215	280	107	17	50	1,1	0,3	0,6	9,5	238-06-050-0065
80	145	295	122	17	31	1,9	0,2	0,9	10,3	238-06-031-0080
80	190	295	122	17	44	1,1	0,3	0,9	10,7	238-06-044-0080
100	155	330	147	17	30	1,9	0,3	1,5	11,7	238-06-030-0100
100	195	330	147	17	44	2,1	0,4	1,5	12,5	238-06-044-0100
125	155	365	178	17	25	3,1	0,4	2,3	13,5	238-06-025-0125
125	205	365	178	17	41	2,8	0,7	2,1	14,8	238-06-041-0125
150	170	395	202	17	24	5,0	0,6	5,1	16,4	238-06-024-0150
150	250	395	202	17	39	8,0	1,3	5,1	19,2	238-06-039-0150

200	185	435	258	22	23	6,3	1,2	8,4	23,9	238-06-023-0200
200	275	435	258	22	37	9,8	2,3	8,4	27,8	238-06-037-0200
250	185	520	312	22	17	15,0	1,7	13,0	30,4	238-06-017-0250
250	275	520	312	22	31	18,0	3,4	13,0	35,7	238-06-031-0250
300	200	585	365	22	19	24,0	2,5	25,0	43,1	238-06-019-0300
300	300	585	365	22	35	26,0	5,5	25,0	52,9	238-06-035-0300
350	245	585	410	27	24	19,0	4,5	30,0	54,0	238-06-024-0350
350	345	585	410	27	34	32,0	7,5	30,0	63,5	238-06-034-0350
400	250	655	465	27	17	42,0	5,7	39,0	60,9	238-06-017-0400
400	310	655	465	27	27	33,0	8,1	39,0	67,6	238-06-027-0400
450	230	710	520	27	14	91,0	6,0	69,0	75,4	238-06-014-0450
450	285	710	520	27	20	50,0	9,0	70,0	79,9	238-06-020-0450
500	255	760	570	27	13	110,0	8,4	60,0	74,4	238-06-013-0500
500	350	760	570	27	20	64,0	15,0	60,0	79,4	238-06-020-0500
600	315	880	670	37	12	214,0	15,0	84,0	118,0	238-06-012-0600
600	385	880	670	37	22	120,0	21,0	86,0	130,0	238-06-022-0600
700	385	995	775	37	18	209,0	28,0	114,0	153,0	238-06-018-0700
700	525	995	775	37	26	186,0	45,0	113,0	178,0	238-06-026-0700
800	395	1110	880	42	16	301,0	36,0	210,0	211,0	238-06-016-0800
800	495	1110	880	42	24	214,0	52,0	211,0	239,0	238-06-024-0800

Weitere Abmessungen und Werkstoffe auf Anfrage.  
/ Other dimensions and materials on request.

## Typ 238 Abmessungen

## Type 238 Specifications

### Ausführung 1

### Model 1

Druckstufe 10 barg (PN 10)

Design pressure 10 barg (PN 10)

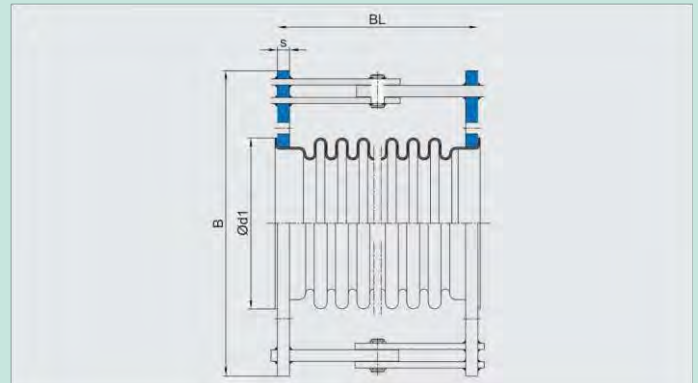

DN	Länge Length	Größte Breite Biggest width	Flansch Flan <sup>g</sup> es		Bewegungsaufnahme Movement angular	Verstellmomentrate Friction rate			Gewicht Weight kg	Artikel Article
	BL mm	B mm	Ød1 mm	s mm		2αN °/deg.	Cα N/mm	Cp N/mm barg		
50	145	260	92	22	38	0,9	0,1	0,4	10,8	238-10-038-0050
50	215	260	92	22	50	0,9	0,2	0,4	11,5	238-10-050-0050
65	145	280	107	22	32	1,4	0,2	0,6	12,0	238-10-032-0065
65	215	280	107	22	49	1,3	0,2	0,6	12,7	238-10-049-0065
80	155	295	122	22	27	2,1	0,2	0,9	13,2	238-10-027-0080
80	240	295	122	22	50	3,6	0,4	0,9	14,8	238-10-050-0080
100	160	330	147	22	29	3,4	0,3	1,5	15,4	238-10-029-0100
100	195	330	147	22	35	2,8	0,4	1,5	15,9	238-10-035-0100
125	195	365	178	22	30	4,1	0,6	2,1	18,6	238-10-030-0125
125	280	365	178	22	42	7,0	1,0	2,1	21,6	238-10-042-0125



150	160	395	208	22	19	11,0	0,5	5,1	22,2	238-10-019-0150
150	245	395	208	22	33	7,6	1,2	5,1	24,6	238-10-033-0150
200	225	435	258	22	27	12,0	1,7	8,4	28,7	238-10-027-0200
200	295	435	258	22	39	17,0	2,4	8,2	33,3	238-10-039-0200
250	235	520	320	27	23	21,0	2,5	13,0	42,7	238-10-023-0250
250	325	520	320	27	33	30,0	4,1	13,0	50,6	238-10-033-0250
300	190	585	370	27	14	52,0	2,3	25,0	52,2	238-10-014-0300
300	275	585	370	27	26	31,0	4,5	25,0	58,9	238-10-026-0300
350	245	600	410	27	23	38,0	4,5	30,0	63,4	238-10-023-0350
350	320	600	410	27	29	47,0	6,6	29,0	69,2	238-10-029-0350
400	210	690	465	32	13	104,0	3,4	39,0	84,0	238-10-013-0400
400	400	690	465	32	29	85,0	12,0	38,0	106,0	238-10-029-0400
450	265	740	520	37	16	107,0	6,6	69,0	114,0	238-10-016-0450
450	330	740	520	37	22	93,0	10,0	69,0	125,0	238-10-022-0450
500	315	805	570	37	20	126,0	11,0	60,0	128,0	238-10-020-0500
500	435	805	570	37	26	131,0	19,0	60,0	144,0	238-10-026-0500
600	275	945	670	43	8	562,0	9,0	119,0	178,0	238-10-008-0600
600	375	945	670	43	19	224,0	19,0	120,0	194,0	238-10-019-0600

Weitere Abmessungen und Werkstoffe auf Anfrage.  
/ Other dimensions and materials on request.

**Typ 238 Abmessungen  
Ausführung 1**

**Type 238 Specifications  
Model 1**

**Druckstufe 16 barg  
Design pressure 16**

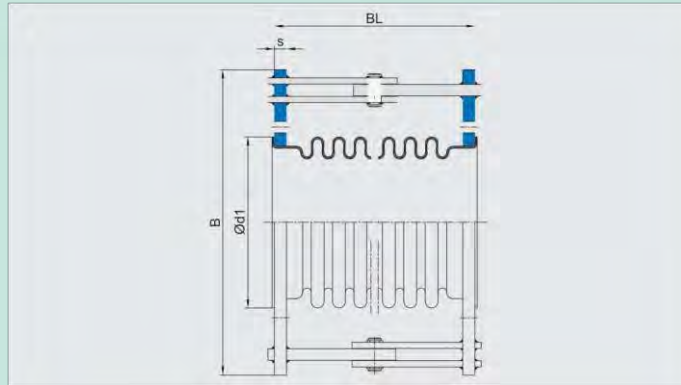

**(PN 16)  
barg (PN 16)**

DN	Länge	Größte Breite		Flansch		Bewegungsaufnahme Movement angular	Verstellmomentrate			Gewicht	Artikel
	Length	Biggest width		Flan <sup>ges</sup>			Friction rate				
	BL	B		Ød1	s	2αN	Cα	Cp	Cr	kg	
	mm	mm		mm	mm	°/deg.	N/mm	N/mm barg	N/barg		
50	145	260	260	92	22	34	0,9	0,1	0,4	10,8	238-16-034-0050
50	225	260	260	92	22	50	1,5	0,2	0,4	11,8	238-16-050-0050
65	145	280	280	107	22	28	1,4	0,2	0,6	12,0	238-16-028-0065
65	220	280	280	107	22	50	2,3	0,3	0,6	13,4	238-16-050-0065
80	155	295	295	122	22	23	2,1	0,2	0,9	13,2	238-16-023-0080
80	240	295	295	122	22	46	3,6	0,4	0,9	14,8	238-16-046-0080
100	160	330	330	147	22	24	3,4	0,3	1,5	15,4	238-16-024-0100
100	210	330	330	147	22	37	4,8	0,5	1,4	16,7	238-16-037-0100
125	190	365	365	178	22	26	6,5	0,6	2,3	19,1	238-16-026-0125
125	225	365	365	178	22	32	7,5	0,7	2,1	20,6	238-16-032-0125
150	195	395	395	208	22	23	9,9	0,8	5,2	23,6	238-16-023-0150
150	265	395	395	208	22	35	14,0	1,3	5,0	26,8	238-16-035-0150
200	245	435	435	258	27	25	18,0	1,7	8,4	34,5	238-16-025-0200
200	340	435	435	258	27	33	32,0	2,8	8,1	41,6	238-16-033-0200
250	225	560	560	320	32	14	47,0	1,9	18,0	59,6	238-16-014-0250
250	265	560	560	320	32	21	33,0	2,6	18,0	63,3	238-16-021-0250
300	255	585	585	375	32	20	54,0	3,3	25,0	69,0	238-16-020-0300
300	345	585	585	375	32	26	63,0	5,8	25,0	81,2	238-16-026-0300
350	215	655	655	410	37	11	116,0	2,8	29,0	91,5	238-16-011-0350
350	255	655	655	410	37	18	75,0	3,8	30,0	96,4	238-16-018-0350

Weitere Abmessungen und Werkstoffe auf Anfrage.  
/ Other dimensions and materials on request.

**Druckstufe 25 barg (PN 25)**  
**Design pressure 25 barg (PN 25)**

DN	Länge Length	Größte Breite Biggest width	Flansch Flan <sup>g</sup> es		Bewegungsaufnahme Movement angular	Verstellmomentrate Friction rate			Gewicht Weight kg	Artikel Article
	BL mm	B mm	Ød1 mm	s mm	2αN °/deg.	Cα N/mm	Cp N/mm barg	Cr N/barg		
50	140	260	92	22	26	1,0	0,1	0,4	10,7	238-25-026-0050
50	195	260	92	22	43	1,9	0,2	0,4	11,4	238-25-043-0050
65	140	280	107	22	24	1,8	0,2	0,5	11,9	238-25-024-0065
65	235	280	107	22	43	3,5	0,3	0,5	13,4	238-25-043-0065
80	165	295	122	22	23	3,2	0,2	0,9	13,5	238-25-023-0080
80	215	295	122	22	36	4,4	0,3	0,9	14,6	238-25-036-0080
100	155	330	147	22	20	6,0	0,3	1,5	16,6	238-25-020-0100
100	210	330	147	22	30	6,6	0,5	1,4	17,7	238-25-030-0100
125	180	365	178	22	19	9,5	0,5	2,1	20,3	238-25-019-0125
125	220	365	178	22	29	12,0	0,7	2,1	22,6	238-25-029-0125
150	190	395	208	27	16	24,0	0,6	5,1	29,5	238-25-016-0150
150	255	395	208	27	27	19,0	1,2	5,0	32,4	238-25-027-0150
200	195	485	258	32	14	53,0	0,9	12,0	51,7	238-25-014-0200
200	250	485	258	32	21	26,0	1,6	12,0	55,3	238-25-021-0200
250	260	560	320	37	17	58,0	2,4	18,0	76,1	238-25-017-0250
250	330	560	320	37	22	60,0	3,5	18,0	82,0	238-25-022-0250
300	290	650	375	43	15	93,0	3,8	24,0	108,0	238-25-015-0300
300	315	650	375	43	19	79,0	4,5	25,0	114,0	238-25-019-0300
350	285	690	410	42	14	129,0	4,5	29,0	125,0	238-25-014-0350
350	315	690	410	42	18	108,0	5,3	29,0	131,0	238-25-018-0350

Weitere Abmessungen und Werkstoffe auf Anfrage. /  
 Other dimensions and materials on request.

**Angularkompensator mit Losflanschen  
 und Kardangeln**

**Angular expansion joint with loose  
 flanges and gimbal hinge Type 239**

**Typ 239**

## Typ 238 Abmessungen Ausführung 1

### Type 238 Specifications

Der Typ 239 ist ein mehrlagiger Angularkompensator mit Losflanschen, Kardangelenk und ist allseitig beweglich.

Er ist speziell konzipiert für den Betrieb in Anlagen mit Betriebsdrücken bis 25 barg.

Dieser Kompensator lässt allseitige angulare Bewegungen zu.

#### Ausführung

Neben den aufgeführten Standardbaulängen kann die Baulänge speziell auf Ihre Bedürfnisse angepasst gefertigt werden. Dieser Kompensator kann auch in anderen Werkstoffen (siehe Seite 179) gefertigt werden.



Type 239 is a multi-layer angular expansion joint with loose flanges, gimbal hinge and moveable in all direction. This expansion joint has a hinge construction.

It is designed specifically for operation in installations with operating pressures up to 25 barg.

This expansion joint allows angular movements in all directions.

#### Description

In addition to the given standard length, other lengths are available to meet specific requirements. This expansion joint can also be produced in other materials (see page 179).

<b>Einsatzbeispiele</b>	Dampfanlagen, Entwässerung	<b>Application examples</b>	Steam plants, water, drainage, etc.
<b>Standardmäßiger Aufbau</b>	Mehrlagiger Werkstoff 1.4541 mit Anschlagverspannung an Anschweißende ist das Anschweißende montagefertig	<b>Standard design</b>	Multi-layer corrugated tube bellows of 1.4541 with weld ends and gimbal hinge construction of carbon steel. From a weld end thickness of 3.5 mm, these parts are bevelled ready for installation.
<b>Zulässige Betriebsdaten (Standard)</b>	16 barg / 120 °C Höhere Drücke	<b>Permissible operating data</b>	16 barg / 120 °C acc. to EJMA Higher pressures on request.
<b>Hinweis</b>	Bei Verwendung vermindert sich Balgquerschnitt bei Ihrer Planur Medienverträglichkeit verwendenden Kompensatorer	<b>Note</b>	Using internal sleeves will reduce the bellows cross-section. To be noted is that the media compatibility of the expansion joint material to be used should be taken into account in the planning phase.

**Typ 239 Abmessungen  
Ausführung 1**

**Type 239 Specifications**

**Model 1**

**Druckstufe 6 barg (PN 6)  
Design pressure 6 barg (PN 6)**

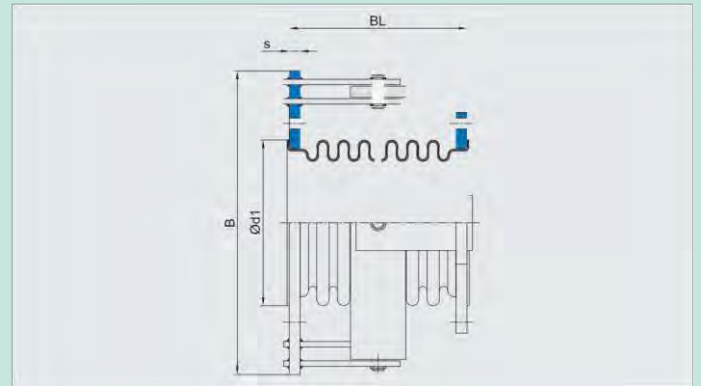

DN	Länge Length	Größe Breite Biggest width	Flansch Flanges		Bewegungsaufnahme Movement angular	Verstellmomentrate Friction rate			Gewicht Weight kg	Artikel Article
	BL mm	B mm	Ød1 mm	s mm		2αN °/deg.	Cα N/mm	Cp N/mm barg		
50	155	260	90	17	49	0,8	0,1	0,4	10,1	239-06-049-0050
50	255	260	90	17	50	0,7	0,2	0,4	11,1	239-06-050-0050
65	145	280	107	17	40	1,1	0,2	0,6	11,5	239-06-040-0065
65	215	280	107	17	50	1,1	0,3	0,6	12,3	239-06-050-0065
80	145	295	122	17	31	1,9	0,2	0,9	14,3	239-06-031-0080
80	190	295	122	17	44	1,1	0,3	0,9	14,8	239-06-044-0080
100	155	330	147	17	30	1,9	0,3	1,5	16,5	239-06-030-0100

## Typ 239 Abmessungen Ausführung 1

### Type 239 Specifications

100	195	330	147	17	44	2,1	0,4	1,5	17,3	239-06-044-0100
125	155	365	178	17	25	3,1	0,4	2,3	20,2	239-06-025-0125
125	205	365	178	17	41	2,8	0,7	2,1	21,5	239-06-041-0125
150	170	395	202	17	24	5,0	0,6	5,1	23,5	239-06-024-0150
150	250	395	202	17	39	8,0	1,3	5,1	26,2	239-06-039-0150
200	185	435	258	22	23	6,3	1,2	8,4	34,8	239-06-023-0200
200	275	435	258	22	37	9,8	2,3	8,4	38,7	239-06-037-0200
250	185	520	312	22	17	15,0	1,7	13,0	48,1	239-06-017-0250
250	275	520	312	22	31	18,0	3,4	13,0	53,6	239-06-031-0250
300	300	585	365	22	32	26,0	5,5	25,0	85,9	239-06-032-0300
350	345	595	410	27	34	32,0	7,5	30,0	86,4	239-06-034-0350
400	310	670	465	27	27	33,0	8,1	39,0	107,0	239-06-027-0400
450	285	730	520	27	19	50,0	9,0	70,0	125,0	239-06-019-0450
500	350	780	570	27	20	64,0	15,0	60,0	138,0	239-06-020-0500
600	385	895	670	37	21	120,0	21,0	86,0	211,0	239-06-021-0600
700	525	1005	775	37	26	186,0	45,0	113,0	300,0	239-06-026-0700
800	495	1120	880	42	19	214,0	52,0	211,0	405,0	239-06-019-0800

Weitere Abmessungen und Werkstoffe auf Anfrage.  
/ Other dimensions and materials on request.

**Typ 239 Abmessungen  
Ausführung 1**

**Type 239 Specifications**

**Model 1**

**Druckstufe 10 barg (PN 10)  
Design pressure 10 barg (PN 10)**

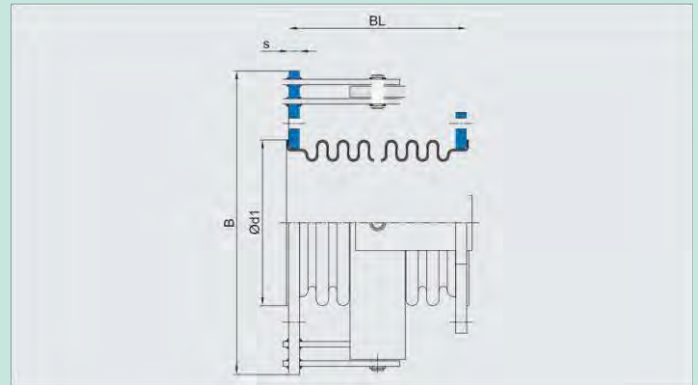

DN	Länge Length	Größte Breite Biggest width	Flansch Flan9es		Bewegungsaufnahme Movement angular	Verstellmomentrate Friction rate			Gewicht Weight kg	Artikel Article
	BL mm	B mm	Ød1 mm	s mm		Cα N/mm	Cp N/mm barg	Cr N/barg		
50	145	260	92	22	32	0,9	0,1	0,4	13,1	239-10-032-0050
50	215	260	92	22	50	0,9	0,2	0,4	13,9	239-10-050-0050
65	145	280	107	22	31	1,4	0,2	0,6	14,7	239-10-031-0065
65	215	280	107	22	49	1,3	0,2	0,6	15,5	239-10-049-0065
80	155	295	122	22	27	2,1	0,2	0,9	17,2	239-10-027-0080
80	240	295	122	22	50	3,6	0,4	0,9	18,8	239-10-050-0080
100	160	330	147	22	29	3,4	0,3	1,5	20,1	239-10-029-0100

## Typ 239 Abmessungen Ausführung 1

## Type 239 Specifications

100	195	330	147	22	35	2,8	0,4	20,6	239-10-035-0100
125	195	365	178	22	30	4,1	0,6	25,3	239-10-030-0125
125	280	365	178	22	42	7,0	1,0	28,4	239-10-042-0125
150	160	395	208	22	19	11,0	0,5	29,3	239-10-019-0150
150	245	395	208	22	33	7,6	1,2	31,7	239-10-033-0150
200	225	435	258	22	25	12,0	1,7	39,7	239-10-025-0200
200	295	435	258	22	39	17,0	2,4	44,2	239-10-039-0200
250	235	520	320	27	23	21,0	2,5	60,4	239-10-023-0250
250	325	520	320	27	33	30,0	4,1	68,6	239-10-033-0250
300	275	585	370	27	26	31,0	4,5	91,8	239-10-026-0300
350	325	610	410	27	29	47,0	6,8	101,0	239-10-029-0350
400	400	695	465	32	29	85,0	12,0	151,0	239-10-029-0400
450	330	750	520	37	21	93,0	10,0	189,0	239-10-021-0450
500	435	805	570	37	26	131,0	19,0	217,0	239-10-026-0500
600	375	955	670	43	19	224,0	19,0	336,0	239-10-019-0600

Weitere Abmessungen und Werkstoffe auf Anfrage.  
/ Other dimensions and materials on request.



## Typ 239 Abmessungen

### Ausführung 1

### Type 239 Specifications

### Model 1

Druckstufe 16 barg (PN 16)

Design pressure 16 barg (PN 16)

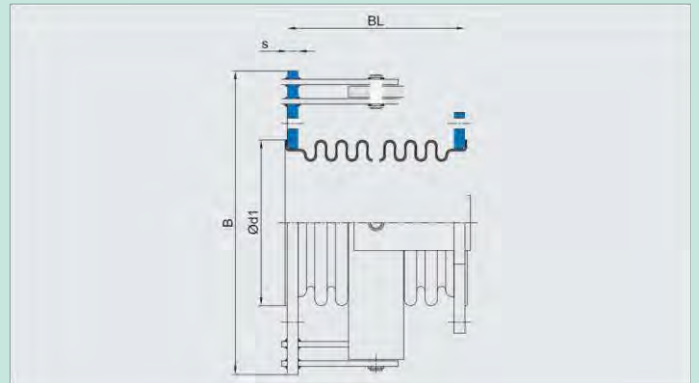

DN	Länge	Größte Breite Biggest width	Flansch Flanges		Bewegungsaufnahme Movement angular	Verstellmomentrate Friction rate			Gewicht Weight	Artikel Article
	Length		B	Ød1		s	2αN	Cα		
	BL	B	Ød1	s	2αN	N/mm	N/mm barg	N/barg	kg	
50	145	260	92	22	32	0,9	0,1	0,4	13,1	239-16-032-0050
50	225	260	92	22	50	1,5	0,2	0,4	14,2	239-16-050-0050
65	145	280	107	22	28	1,4	0,2	0,6	14,7	239-16-028-0065
65	220	280	107	22	50	2,3	0,3	0,6	16,1	239-16-050-0065
80	155	295	122	22	23	2,1	0,2	0,9	17,2	239-16-023-0080
80	240	295	122	22	46	3,6	0,4	0,9	18,8	239-16-046-0080
100	160	330	147	22	24	3,4	0,3	1,5	20,1	239-16-024-0100
100	210	330	147	22	37	4,8	0,5	1,4	21,5	239-16-037-0100
125	190	365	178	22	26	6,5	0,6	2,3	25,9	239-16-026-0125
125	225	365	178	22	32	7,5	0,7	2,1	27,4	239-16-032-0125
150	195	395	208	22	23	9,9	0,8	5,2	33,2	239-16-023-0150
150	265	395	208	22	35	14,0	1,3	5,0	36,4	239-16-035-0150
200	245	435	258	27	25	18,0	1,7	8,4	45,6	239-16-025-0200
200	340	435	258	27	33	32,0	2,8	8,1	52,7	239-16-033-0200
250	225	560	320	32	14	47,0	1,9	18,0	96,3	239-16-014-0250
250	265	560	320	32	21	33,0	2,6	18,0	100,0	239-16-021-0250
300	345	585	375	32	26	63,0	5,8	25,0	115,0	239-16-026-0300
350	255	660	410	37	18	75,0	3,8	30,0	145,0	239-16-018-0350

## Typ 239 Abmessungen Ausführung 1

### Type 239 Specifications

Weitere Abmessungen  
und Werkstoffe auf Anfrage. / Other  
dimensions and materials on request.

#### Druckstufe 25 barg (PN 25) Design pressure 25 barg (PN 25)

DN	Länge Length	Größte Breite Biggest width	Flansch Flan <sup>g</sup> es		Bewegungsaufnahme Movement angular	Verstellmomentrate Friction rate			Gewicht Weight	Artikel Article
	BL mm	B mm	Ød1 mm	s mm	2αN °/deg.	Cα N/mm	Cp N/mm barg	Cr N/barg	kg	
50	140	260	92	22	26	1,0	0,1	0,4	13,1	239-25-026-0050
50	195	260	92	22	43	1,9	0,2	0,4	13,8	239-25-043-0050
65	140	280	107	22	24	1,8	0,2	0,5	14,7	239-25-024-0065
65	235	280	107	22	43	3,5	0,3	0,5	16,2	239-25-043-0065
80	165	295	122	22	23	3,2	0,2	0,9	17,5	239-25-023-0080
80	215	295	122	22	36	4,4	0,3	0,9	18,7	239-25-036-0080
100	155	330	147	22	20	6,0	0,3	1,5	21,3	239-25-020-0100
100	210	330	147	22	30	6,6	0,5	1,4	22,4	239-25-030-0100
125	180	365	178	22	19	9,5	0,5	2,1	27,0	239-25-019-0125
125	220	365	178	22	29	12,0	0,7	2,1	29,4	239-25-029-0125
150	190	395	208	27	16	24,0	0,6	5,1	39,2	239-25-016-0150
150	255	395	208	27	27	19,0	1,2	5,0	42,1	239-25-027-0150
200	250	485	258	32	21	26,0	1,6	12,0	77,0	239-25-021-0200
250	330	560	320	37	22	60,0	3,5	18,0	119,0	239-25-022-0250
300	315	650	375	43	19	79,0	4,5	25,0	175,0	239-25-019-0300
350	315	690	410	42	18	108,0	5,3	29,0	198,0	239-25-018-0350

Weitere Abmessungen und Werkstoffe auf Anfrage.  
/ Other dimensions and materials on  
request.

## Universalkompensator Anschweißenden mit

### Typ 240

Der Typ 240 ist ein mehrlagiger Universalkompensator in Doppelbalgausführung mit Zwischenrohr und Anschweißenden.

Er ist speziell konzipiert für den Betrieb in Anlagen mit geringen Betriebsdrücken (bis maximal 1 barg).

Dieser Kompensator lässt sowohl axiale, laterale wie auch angulare Bewegungen zu.

#### Beschreibung

Die angegebenen Bewegungen gelten nicht in Kombination. Der Gesamtnutzungsfaktor darf 1 nicht überschreiten. Eine 100%ige axiale Verwendung lässt keine laterale Bewegung mehr zu.

Neben den aufgeführten Standardbaulängen kann die Baulänge speziell auf Ihre Bedürfnisse angepasst gefertigt werden. Dieser Kompensator kann auch in anderen Werkstoffen (siehe Seite 179) gefertigt werden.

Die angegebenen Bewegungen stellen die einzelnen Maximalwerte dar. Zur Ermittlung kombinierter Bewegungsmöglichkeiten verwenden Sie bitte das Bewegungsschaubild auf Seite 10.

#### Anwendung

Universalkompensatoren kommen in einer Vielzahl von Anwendungen zum Einsatz, z. B. Turbinenauslassstutzen, Aggregaten, Generatoren, Schiffsantriebe, Erstausrüster-Motoren und Hilfssysteme.

Universalkompensatoren können für jede spezielle Anforderung und Anwendung kundenspezifisch angefertigt werden.

#### Vorteile

- Gasdicht und beständig gegen Korrosion und hohen Temperaturen. ▫ Nimmt Schwingungen auf
- Die leichte Bauweise in Kombination mit sehr niedrigen Federraten verringern die auf die Rohrleitungskomponenten wirksamen Lasten.
- Platzsparend



## Typ 241 (mit Innenleitrohr) Universal expansion joint with weld ends

### Type 240

### Type 241 (with internal sleeve)

Type 240 is a multi-layer universal expansion joint with double bellows with intermediate pipe and weld ends.

It is designed specifically for operation in installations with low operating pressures (up to maximum 1 barg).

This expansion joint allows axial, lateral and angular movements.

#### Description

The specified movements do not apply to combinations. The total utilisation factor must not exceed 1. With 100 % utilisation of the axial movement, no further lateral movement is permissible.

In addition to the given standard lengths, other lengths are available to meet specific requirements. This expansion joint can also be produced in other materials (see page 179).

The specified movements represent the individual maximum values. For determining combined movements, refer to the movement diagram on page 10.

#### Applications

Universal expansion joints are used in a wide range of applications, e.g. turbine exhausts, apparatus, generators, marine propulsion, OEM motors and auxiliary systems.

Universal expansion joints can be made to suit all specific customer requirements and applications.

#### Advantages

- Gas-tight and resistant to corrosion and high temperatures
- Absorb vibrations
- Lightweight design combined with very low spring rates reduce loads exerted on pipeline components
- Space-saving

## Universalkompensator mit Anschweißenden

### Typ 240

## Typ 241 (mit Innenleitrohr) Universal expansion joint

**Einsatzbeispiele** Flüssige und gasförmige Medien im Niederdruckbetrieb, z. B. Abgasanlagen im Schiffbau, Biogasanlagen, Blockheizkraftwerke etc.

**Standardmäßiger Aufbau** Mehrlagiger Wellrohrbalg aus 1.4541 mit Anschweißenden aus 1.0345/P235 (HI) bzw. ab DN 500 1.0425/P265 (HII). Ab einer Anschweißendendicke von 3,5 mm ist dieses montagefertig gefast.

**Zulässige Betriebsdaten** (Standard) max. 2,5 barg / 20 °C / 1000 Lastwechsel  
Höhere Drücke auf Anfrage.

**Zubehör** Innenleitrohr, Außenschutzrohr

**Hinweis** Bei Verwendung von Leitrohren vermindert sich die Möglichkeit der Aufnahme der lateralen oder angularen Bewegungen um mind. 90 %. Bitte beachten Sie bei Ihrer Planung die Medienverträglichkeit der zu verwendenden Kompensatorenmaterialien.

**Application examples** Liquid and gaseous media in low pressure operation, e.g. exhaust systems in shipbuilding, biogas plants, block-type thermal power stations, etc.

**Standard design** Multi-layer corrugated tube bellows of 1.4541 with weld ends of 1.0345/P235 (HI) and from DN 500 1.0425/P265 (HII). From a weld end thickness of 3.5 mm, these parts are bevelled ready for installation.

**Permissible operating data** max. 2.5 barg / 20 °C / 1000 load cycles. Higher pressures on request.

**Accessories** Internal sleeve, external protective sleeve

**Note** When using internal sleeves, the possibility to compensate for lateral or angular movements reduces by minimum 90 %. To be noted is that the media compatibility of the expansion joint material to be used should be taken into account in the planning phase.

with weld ends

Type 240

Type 241 (with internal sleeve)

**Typ 240 Abmessungen  
Ausführung 2**

**Type 240 Specifications  
Model 2**

**Druckstufe 2,5 barg (PN 2,5)  
Design pressure 2.5 barg (PN 2.5)**

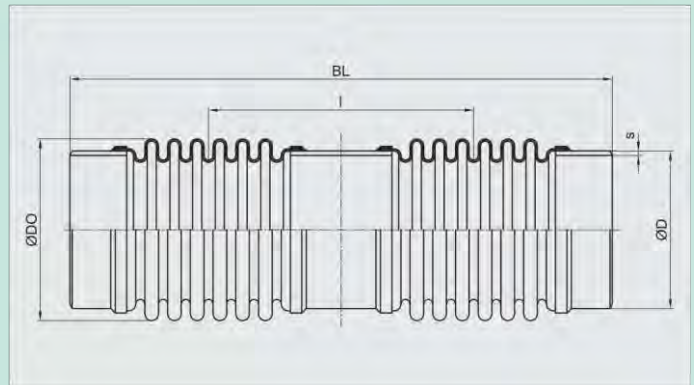

DN	Länge Length	Balg Bellow			Anschweißenden Weld ends			gsaufnahme vement		Ikkrafrate Sprngrate		Gewicht Weight	Artikel Article
		BL mm	ØDO mm	WF* mm	I** cm <sup>2</sup>	ØD mm	s mm	axial 2δN mm	lateral 2λN mm	axial Cδ N/mm	lateral Cλ N/mm		
50	410	69	28	195	60,3	2,9	47	122	47,0	2,1	1,3	240-2,5-047-0050	
65	420	87	46	215	76,1	2,9	54	123	42,0	2,5	1,7	240-2,5-054-0065	
80	415	114	79	248	88,9	3,2	52	123	42,0	3,4	2,9	240-2,5-052-0080	
100	420	145	131	255	114,3	3,6	75	123	26,0	3,2	4,2	240-2,5-075-0100	
125	440	171	188	275	139,7	4,0	76	124	30,0	4,6	6,0	240-2,5-076-0125	
150	470	204	271	294	168,3	4,5	83	121	33,0	6,4	7,4	240-2,5-083-0150	
200	430	262	446	205	219,1	6,3	151	84	45,0	27,0	12,3	240-2,5-151-0200	
250	455	309	663	268	273,0	6,3	101	81	39,0	22,0	15,6	240-2,5-101-0250	
300	445	365	927	253	323,9	7,1	127	80	46,0	41,0	21,6	240-2,5-127-0300	
350	495	396	1104	283	355,6	6,3	120	80	53,0	45,0	22,8	240-2,5-120-0350	
400	560	453	1451	310	406,4	6,3	142	80	52,0	47,0	28,6	240-2,5-142-0400	
450	540	511	1842	310	457,0	6,3	149	81	45,0	53,0	33,6	240-2,5-149-0450	
500	570	566	2263	330	508,0	6,3	164	82	47,0	60,0	38,3	240-2,5-164-0500	
600	630	679	3257	390	610,0	6,0	150	81	84,0	110,0	48,1	240-2,5-150-0600	
700	710	777	4335	450	711,0	6,0	146	81	98,0	129,0	70,8	240-2,5-146-0700	
800	780	886	5654	550	813,0	6,0	124	79	110,0	129,0	96,6	240-2,5-124-0800	
900	830	990	7110	600	914,0	6,0	126	81	113,0	141,0	105,0	240-2,5-126-0900	
1000	710	1098	8765	420	1016,0	6,0	230	80	60,0	181,0	106,0	240-2,5-230-1000	
1100	720	1198	10540	440	1120,0	6,0	169	61	94,0	317,0	114,0	240-2,5-169-1100	
1200	785	1264	11794	472	1220,0	6,0	161	60	106,0	352,0	124,0	240-2,5-161-1200	
1300	785	1364	13818	442	1320,0	6,0	193	60	99,0	430,0	123,0	240-2,5-193-1300	
1400	815	1464	15980	472	1420,0	6,0	192	60	106,0	470,0	138,0	240-2,5-192-1400	
1500	845	1564	18299	502	1520,0	6,0	191	60	113,0	510,0	155,0	240-2,5-191-1500	
1600	875	1664	20776	532	1620,0	6,0	190	61	120,0	550,0	172,0	240-2,5-190-1600	
1700	735	1764	23409	392	1720,0	6,0	189	40	127,0	1190,0	147,0	240-2,5-189-1700	
1800	755	1864	26199	412	1820,0	6,0	189	40	134,0	1280,0	161,0	240-2,5-189-1800	
1900	785	1963	29132	442	1920,0	6,0	185	40	147,0	1350,0	179,0	240-2,5-185-1900	
2000	815	2061	32204	473	2020,0	6,0	177	40	166,0	1490,0	197,0	240-2,5-177-2000	
2100	755	2161	35466	407	2120,0	6,0	223	39	135,0	1770,0	198,0	240-2,5-223-2100	
2200	785	2260	38865	437	2220,0	6,0	218	40	147,0	1840,0	217,0	240-2,5-218-2200	

\*WF = wirksame Fläche / effective area Weitere Abmessungen und Werkstoffe auf Anfrage. / \*\*I = Mittenabstand / center distance Other dimensions and materials on request.

## Universalkompensator mit drehbaren Losflanschen

### Typ 242

### Typ 243 (mit Innenleitrohr)

Der Typ 242 ist ein mehrlagiger Universalkompensator in Doppelbalgausführung mit Zwischenrohr und mit drehbaren Losflanschen.

Er ist speziell konzipiert für den Betrieb in Anlagen mit geringen Betriebsdrücken (bis max. 2,5 barg).

Dieser Kompensator lässt sowohl axiale, laterale wie auch angulare Bewegungen zu.

#### Beschreibung

Neben den aufgeführten Standardbaulängen kann die Baulänge speziell auf Ihre Bedürfnisse angepasst gefertigt werden. Dieser Kompensator kann auch in anderen Werkstoffen (siehe Seite 179) gefertigt werden.

Die angegebenen Bewegungen stellen die einzelnen Maximalwerte dar. Zur Ermittlung kombinierter Bewegungsmöglichkeiten verwenden Sie bitte das Bewegungsschaubild auf Seite 10.

#### Anwendung

Universalkompensatoren kommen in einer Vielzahl von Anwendungen zum Einsatz, z. B. Turbinenauslassstutzen, Aggregaten, Generatoren, Schiffsantriebe, Erstausrüster-Motoren und Hilfssysteme.

Universalkompensatoren können für jede spezielle Anforderung und Anwendung kundenspezifisch angefertigt werden.

#### Vorteile

- Gasdicht und beständig gegen Korrosion und hohen Temperaturen
- Nimmt Schwingungen auf
- Die leichte Bauweise in Kombination mit sehr niedrigen Federraten verringern die auf die Rohrleitungskomponenten wirksamen Lasten
- Platzsparend

## Universal expansion joint with loose flanges

### Type 242

### Type 243 (with internal sleeve)



Type 242 is a multi-layer universal expansion joint with double bellows with intermediate pipe and loose flanges.

It is designed specifically for operation in installations with low operating pressures (up to maximum 2.5 barg).

This expansion joint allows axial, lateral and angular movements.

#### Description

In addition to the given standard lengths, other lengths are available to meet specific requirements. This expansion joint can also be produced in other materials (see page 179).

The specified movements represent the individual maximum values. For determining combined movements, refer to the movement diagram on page 10.

#### Applications

Universal expansion joints are used in a wide range of applications, e.g. turbine exhausts, apparatus, generators, marine propulsion, OEM motors and auxiliary systems.

Universal expansion joints can be made to suit all specific customer requirements and applications.

#### Advantages

- Gas-tight and resistant to corrosion and high temperatures
- Absorb vibrations
- Lightweight design combined with very low spring rates reduce loads exerted on pipeline components
- Space-saving

## Universalkompensator mit drehbaren Losflanschen

### Typ 242

### Typ 243 (mit Innenleitrohr)

### Universal expansion joint

#### Einsatzbeispiele

Flüssige und gasförmige Medien im Niederdruckbetrieb, z. B. Abgasanlagen im Schiffbau, Biogasanlagen, Blockheizkraftwerke etc.

#### Standardmäßiger Aufbau

Mehrlagiger Wellrohrbalg aus 1.4541 mit glatten Flanschen aus C-Stahl (roh) gebohrt nach DIN 86044-1. Der Bördel besteht aus umgeformtem Balgmaterial.

#### Zulässige Betriebsdaten (Standard)

max. 2,5 barg / 20 °C / 1000 Lastwechsel.  
Höhere Drücke auf Anfrage.

#### Zubehör

Innenleitrohr, Außenschutzrohr

#### Hinweis

Bei Verwendung von Leitrohren vermindert sich die Möglichkeit der Aufnahme der lateralen oder angularen Bewegungen um mind. 90 %. Bitte beachten Sie bei Ihrer Planung die Medienverträglichkeit der zu verwendenden Kompensatorenmaterialien.

#### Application examples

Liquid and gaseous media in low pressure operation, e.g. exhaust systems in shipbuilding, biogas plants, block-type thermal power stations, etc.

#### Standard design

Multi-layer corrugated tube bellows of 1.4541 with flat flanges of carbon steel (raw) drilled according to DIN 86044-1. The flange is made from formed bellows material.

#### Permissible operating data

max. 2.5 barg / 20 °C / 1000 load cycles  
Higher pressures on request.

#### Accessories

Internal sleeve, external protective sleeve

#### Note

When using internal sleeves, the possibility to compensate for lateral or angular movements reduces by minimum 90 %. To be noted is that the media compatibility of the expansion joint material to be used should be taken into account in the planning phase.

## with loose flanges

### Type 242

### Type 243 (with internal sleeve)

**Typ 242 Abmessungen**  
**Ausführung 2**

**Type 242 Specifications**  
**Model 2**

**Druckstufe 2,5 barg (PN 2,5)**  
**Design pressure 2.5 barg (PN 2.5)**

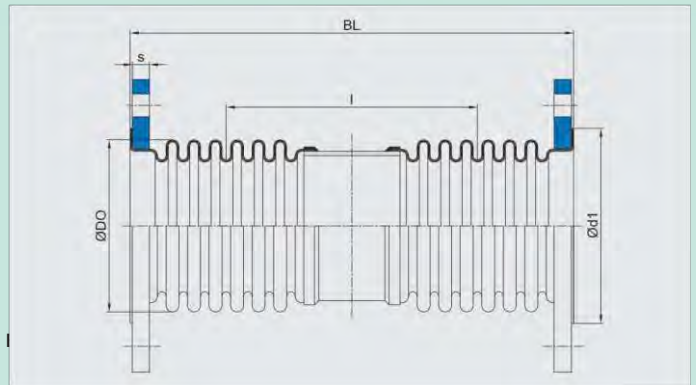

DN	Länge Length	Balg Bellows			Flansch Flanges		gsaufnahme vement		Ilkraftrate ingrate		Gewicht Weight	Artikel Article
		BL mm	ØDO mm	WF* mm	I** cm <sup>2</sup>	Ød1 mm	s mm	axial 2ØN mm	lateral 2λN mm	axial Cδ N/mm		
50	350	69	28	196	90	16	47	123	47	2,1	3,9	242-2,5-047-0050
65	360	87	46	215	107	16	54	122	42	2,5	5,1	242-2,5-054-0065
80	385	114	79	249	122	18	52	124	42	3,7	8,0	242-2,5-052-0080
100	395	145	131	254	147	18	75	119	26	3,7	9,6	242-2,5-075-0100
125	415	171	188	272	178	20	76	123	30	5,4	13,0	242-2,5-076-0125
150	440	204	271	284	202	20	83	120	33	8,0	15,0	242-2,5-083-0150
200	440	257	437	277	258	22	77	81	102	41,0	25,3	242-2,5-077-0200
250	440	309	663	266	312	24	101	80	39	26,0	28,5	242-2,5-101-0250
300	440	365	927	255	365	24	127	81	46	47,0	38,8	242-2,5-127-0300
350	470	396	1104	288	410	26	120	82	53	49,0	51,2	242-2,5-120-0350
400	540	453	1451	312	465	28	142	81	52	54,0	59,6	242-2,5-142-0400
450	525	511	1842	312	520	30	149	80	45	60,0	72,9	242-2,5-149-0450



500	555	566	2263	326	570	30	164	81	47	71,0	79,4	242-2,5-164-0500
600	645	679	3257	395	670	32	150	82	84	135,0	109,0	242-2,5-150-0600
700	700	777	4335	444	775	40	146	79	98	154,0	156,0	242-2,5-146-0700
800	785	886	5654	553	880	44	124	80	110	145,0	218,0	242-2,5-124-0800
900	850	990	7110	596	980	48	126	80	113	165,0	261,0	242-2,5-126-0900
1000	740	1098	8765	422	1080	52	230	76	60	222,0	278,0	242-2,5-230-1000
1200	720	1264	11794	473	1280	60	161	61	106	352,0	361,0	242-2,5-161-1200
1400	715	1464	15980	474	1466	42	192	60	106	468,0	320,0	242-2,5-192-1400
1600	785	1664	20776	534	1666	47	191	61	120	548,0	439,0	242-2,5-191-1600
1800	675	1864	26199	414	1866	52	189	40	134	1270,0	497,0	242-2,5-189-1800
2000	735	2061	32204	473	2066	52	177	40	166	1480,0	565,0	242-2,5-177-2000
2200	715	2260	38865	439	2266	57	218	40	147	1840,0	710,0	242-2,5-218-2200

\*WF = wirksame Fläche / effective area Weitere Abmessungen und Werkstoffe auf Anfrage. / \*\*I = Mittenabstand / center distance Other dimensions and materials on request.

## Universalkompensator mit Festflanschen

### Typ 244

Der Typ 244 ist ein mehrlagiger Universalkompensator in Doppelbalgausführung mit Zwischenrohr und mit Festflanschen.

Er ist speziell konzipiert für den Betrieb in Anlagen mit geringen Betriebsdrücken (bis max. 2,5 barg)

Dieser Kompensator lässt sowohl axiale, laterale wie auch angulare Bewegungen zu.

#### Beschreibung

Neben den aufgeführten Standardbaulängen kann die Baulänge speziell auf Ihre Bedürfnisse angepasst gefertigt werden. Dieser Kompensator kann auch in anderen Werkstoffen (siehe Seite 179) gefertigt werden.

Die angegebenen Bewegungen stellen die einzelnen Maximalwerte dar. Zur Ermittlung kombinierter Bewegungsmöglichkeiten verwenden Sie bitte das Bewegungsschaubild auf Seite 10.

#### Anwendung

Universalkompensatoren kommen in einer Vielzahl von Anwendungen zum Einsatz, z. B. Turbinenauslassstutzen, Aggregaten, Generatoren, Schiffsantriebe, ErstausrüsterMotoren und Hilfssysteme.

## Typ 245 (mit Innenleitrohr)

### Universal expansion joint with fixed flanges

#### Type 244

#### Type 245 (with internal sleeve)

##### Vorteile

- Gasdicht und beständig gegen Korrosion und hohen Temperaturen. ▫ Nimmt Schwingungen auf
- Die leichte Bauweise in Kombination mit sehr niedrigen Federraten verringern die auf die Rohrleitungskomponenten wirksamen Lasten.
- Platzsparend



Type 244 is a multi-layer universal expansion joint with double bellows with intermediate pipe and fixed flanges.

It is designed specifically for operation in installations with low operating pressures (up to maximum 2.5 barg).

This expansion joint allows axial, lateral and angular movements.

### Description

In addition to the given standard lengths, other lengths are available to meet specific requirements. This expansion joint can also be produced in other materials (see page 179).

The specified movements represent the individual maximum values. For determining combined movements, refer to the movement diagram on page 10.

### Applications

Universal expansion joints are used in a wide range of applications, e.g. turbine exhausts, apparatus, generators, marine propulsion, OEM motors and auxiliary systems.

### Advantages

- Gas-tight and resistant to corrosion and high temperatures
- Absorb vibrations
- Lightweight design combined with very low spring rates reduce loads exerted on pipeline components
- Space-saving

## Universalkompensator mit Festflanschen

### Typ 244

### Typ 245 (mit Innenleitrohr)

#### Universal

**Einsatzbeispiele** Flüssige und gasförmige Medien im Niederdruckbetrieb, z. B. Abgasanlagen im Schiffbau, Biogasanlagen, Blockheizkraftwerke etc.

#### Standardmäßiger Aufbau

Mehrlagiger Wellrohrbalg aus 1.4541 mit glatten Flanschen aus C-Stahl (roh) gebohrt nach DIN 86044-1.

**Zulässige Betriebsdaten (Standard)** max. 2,5 barg / 20 °C / 1000 Lastwechsel  
Höhere Drücke auf Anfrage.

**Zubehör** Innenleitrohr, Außenschutzrohr

**Hinweis** Bei Verwendung von Leitrohren vermindert sich die Möglichkeit der Aufnahme der lateralen oder angularen Bewegungen um mind. 90 %. Bitte beachten Sie bei Ihrer Planung die Medienverträglichkeit der zu verwendenden Kompensatorenmaterialien.

## Type 245 (with internal sleeve)

#### Application examples

Liquid and gaseous media in low pressure operation, e.g. exhaust systems in shipbuilding, biogas plants, block-type thermal power stations, etc.

#### Standard design

Multi-layer corrugated tube bellows of 1.4541 with flat flanges of carbon steel (raw) drilled according to DIN 86044-1.

#### Permissible operating data

max. 2.5 barg / 20 °C / 1000 load cycles  
Higher pressures on request.

#### Accessories

Internal sleeve, external protective sleeve

#### Note

When using internal sleeves, the possibility to compensate for lateral or angular movements reduces by minimum 90 %. To be noted is that the media compatibility of the expansion joint material to be used should be taken into account in the planning phase.

## expansion joint with fixed flanges

### Type 244

**Typ 244 Abmessungen  
Ausführung 2**

**Type 244 Specifications  
Model 2**

**Druckstufe 2,5 barg (PN 2,5)  
Design pressure 2.5 barg (PN 2.5)**

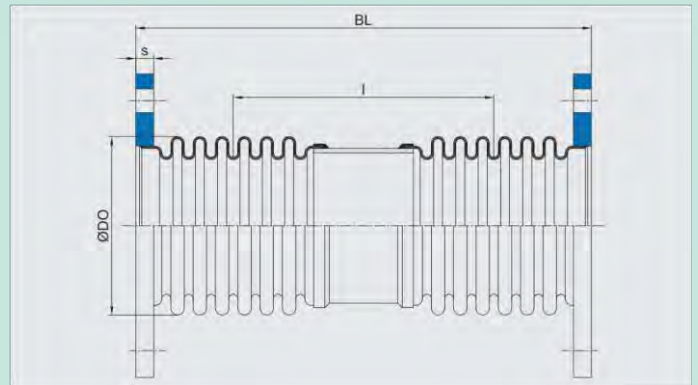

DN	Länge Length	Balg Bellow			Flansch Flanges	gsaufnahme vement		ellkräfte ingrate		Gewicht Weight	Artikel Article
		BL mm	ØDO mm	WF* mm		I** cm <sup>2</sup>	s mm	axial 2δN mm	lateral 2λN mm		
50	340	69	28	194	16	47	123	47,0	2,1	3,9	244-2,5-047-0050
65	350	87	46	214	16	54	122	42,0	2,5	4,9	244-2,5-054-0065
80	365	114	79	250	18	52	124	42,0	3,6	8,0	244-2,5-052-0080
100	370	145	131	252	18	75	119	26,0	3,8	9,4	244-2,5-075-0100
125	395	171	188	273	20	76	123	30,0	5,4	12,6	244-2,5-076-0125
150	420	204	271	285	20	83	120	33,0	8,0	14,6	244-2,5-083-0150
200	415	257	437	276	22	77	81	102,0	42,0	25,3	244-2,5-077-0200
250	415	309	663	264	24	101	80	39,0	26,0	27,5	244-2,5-101-0250
300	420	365	927	256	24	127	81	46,0	47,0	38,8	244-2,5-127-0300
350	450	396	1104	289	26	120	82	53,0	49,0	51,2	244-2,5-120-0350
400	520	453	1451	312	28	142	81	52,0	53,0	59,6	244-2,5-142-0400
450	500	511	1842	310	30	149	80	45,0	60,0	70,7	244-2,5-149-0450
500	535	566	2263	328	30	164	81	47,0	71,0	79,4	244-2,5-164-0500

600	620	679	3257	393	32	150	82	84,0	136,0	109,0	244-2,5-150-0600
700	680	777	4335	445	40	146	79	98,0	153,0	156,0	244-2,5-146-0700
800	765	886	5654	554	44	124	80	110,0	145,0	218,0	244-2,5-124-0800
900	825	990	7110	594	48	126	80	113,0	166,0	251,0	244-2,5-126-0900
1000	720	1098	8765	423	52	230	76	60,0	220,0	265,0	244-2,5-230-1000
1200	745	1264	11794	472	60	161	61	106,0	352,0	361,0	244-2,5-161-1200
1400	740	1464	15980	473	42	192	60	106,0	468,0	320,0	244-2,5-192-1400
1600	810	1664	20776	533	47	191	61	120,0	548,0	438,0	244-2,5-190-1600
1800	700	1864	26199	413	52	189	40	134,0	1270,0	494,0	244-2,5-189-1800
2000	760	2061	32204	473	52	177	40	166,0	1490,0	565,0	244-2,5-177-2000
2200	740	2260	38865	438	57	218	40	147,0	1840,0	707,0	244-2,5-218-2200

\*WF = wirksame Fläche / effective area Weitere Abmessungen und Werkstoffe auf Anfrage. / \*\*I = Mittenabstand / center distance

Other dimensions and materials on request.

## Axialkompensator

### mit Gewindeanschluss

#### Typ 246

Der Typ 246 ist ein einlagiger Heizungskompensator mit Gewindeanschlüssen. Er wird in 2 Ausführungen ausgeführt:

##### Ausführung I

Balg aus nichtrostendem Stahl (1.4541) PN 16 mit Gewindeanschluss (Außengewinde nach DIN ISO 7/1). Rohrende mit Außengewinde aus Stahl S235JRG2 (RSt.37-2).

Auch komplett aus Edelstahl auf Anfrage lieferbar.

##### Ausführung II

Balg aus nichtrostendem Stahl (1.4541) PN 16 mit flachdichtendem Bund, verzinkter Überwurfmutter mit Einschraubteil und Innengewinde aus Temperguss, Gewindeanschluss nach DIN EN 10226 (ISO 7/1).

Auch komplett aus Edelstahl auf Anfrage lieferbar.

## Axial expansion joint

### with thread connection

#### Type 246

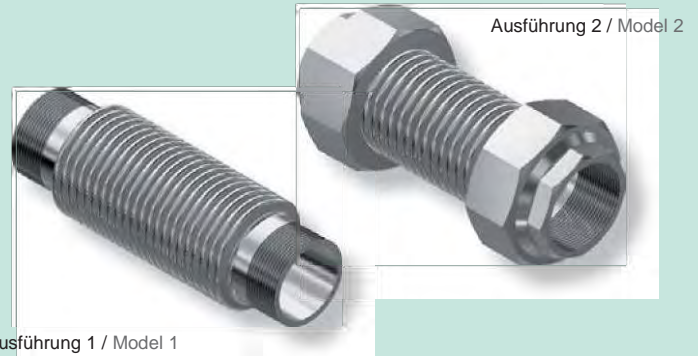

Type 246 is a single layer heating expansion joint with thread connections. It is available in 2 versions:

##### Version I

Stainless steel bellows (1.4541) PN 16 with threaded connection (external thread according to DIN ISO 7/1). Pipe end with external steel thread S235JRG2 (RSt.37-2). All stainless steel versions are available on request.

## Typ 246 Abmessungen

Stainless steel bellows (1.4541) PN 16 with flat sealing flange, galvanized union nut with threaded part and internal thread of malleable cast iron, threaded connection according to DIN EN 10226 (ISO 7/1). All stainless steel version available on request.

<b>Einsatz</b>	Heizungsanlagen
<b>Zulässige Betriebsdaten</b>	max. 16 barg
<b>Hinweis</b>	Auf Anfrage mit DGWV-Zulassung lieferbar. Nicht für Schwingungen geeignet.

<b>Application examples</b>	Heating systems
<b>Permissible operating data</b>	max. 16 barg
<b>Note</b>	Available with DGWV approval on request. Not suitable for vibrations.



## Ausführung 1

### Type 246 Specifications Model 1

**Druckstufe 16 barg (PN 16)**  
Design pressure 16 barg (PN 16)

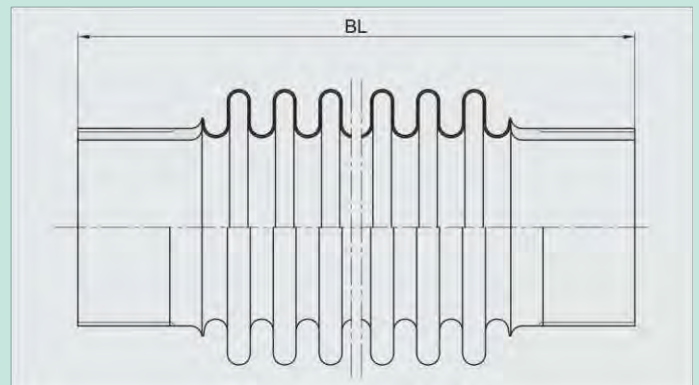

DN	Länge Length BL mm	Bewegungsaufnahme Movement axial +/- mm	Gewicht Weight kg	Artikel Article
15	170	10,0	0,2	20460AG115
20	170	10,0	0,2	20460AG120
25	170	12,5	0,3	20460AG125
32	185	12,5	0,4	20460AG132
40	200	12,5	0,5	20460AG140
50	225	15,0	0,8	20460AG150

Weitere Abmessungen und Werkstoffe auf Anfrage.  
/ Other dimensions and materials on request.

## Typ 246 Abmessungen Ausführung 2

## Type 246 Specifications Model 2

Druckstufe 16 barg (PN 16)  
Design pressure 16 barg (PN 16)

DN	Länge Length BL mm	Bewegungsaufnahme Movement axial +/- mm	Gewicht Weight kg	Artikel Article
15	118	6,0	0,4	2046211510
20	143	9,0	0,5	2046212010
25	145	10,0	0,5	2046212510
32	154	11,0	1,0	2046213210
40	158	11,0	1,2	2046114010
50	204	15,0	1,9	2046215010

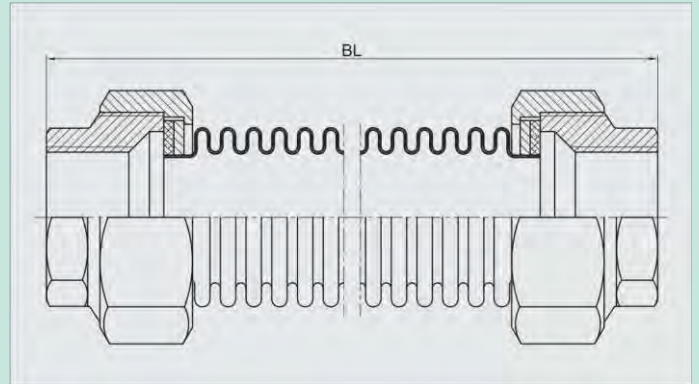

Weitere Abmessungen und Werkstoffe auf Anfrage.  
/ Other dimensions and materials on request.

## Ausbaustück

### Typ 250

### Typ 251 (mit Innenleitrohr)

WILLBRANDT Ausbaustücke dienen ausschließlich zur Unterstützung beim Aus- und Wiedereinbau von Armaturen bei Wartungsarbeiten.

Durch die axiale Bewegung des Balges wird in der Rohrleitung eine Baulücke geschaffen, die eine einfache Montage und/oder Demontage der Rohrkomponenten ermöglicht

Bitte beachten Sie hierzu die gesonderten Montagerichtlinien.

Ausbaustücke basieren auf der Grundausstattung eines Axialkompensators (Balg + Flanschen) und sind zuzüglich mit

verlängerten Gewindestangen sowie einer Außenverspannung über Kontermuttern ausgerüstet.

#### Optionale Ausrüstung

Ausbaustücke können über zusätzliche innere Sechskantmutter zur feststellbaren Variante aufgerüstet werden. Innenleitrohre sind bei abrasiven Medien möglich. Durch die Ausstattung mit einem äußeren Schutzmantel ist ein Erdeinbau möglich.

#### Ausführung

Andere Materialien, Nennweiten und Ausführungen sind auf Anfrage möglich.

Technische Ausführung siehe Typ 212 (mit Losflanschen) oder Typ 214 (mit Festflanschen).

## Anzahl der Zugstangen Numbers of tie rods Dismantling piece

### Type 250 | Type 251 (with internal sleeve)

<b>Nennweiten</b>	DN 40 bis DN 1000 Größere Nennweiten auf Anfrage.
<b>Standardmäßiger Aufbau</b>	Balg 1.4541 oder 1.4571. Anschlüsse aus C-Stahl. Leitrohr und Schutzmantel aus Edelstahl.
<b>Zulässige Betriebsdaten (Standard)</b>	16 barg / 120 °C gem. EJMA Höhere Drücke auf Anfrage.
<b>Zubehör</b>	Innenleitrohr, Außenschutzrohr



dismantling pieces simplify the removal and installation of valves during maintenance.

The axial movement of the bellows creates a gap in the pipeline to facilitate the installation and/or removal of pipe components

Please refer to the separate installation instructions.

Dismantling pieces are basic components of an axial expansion joint (bellows + flanges) and are additionally equipped with extended threaded rods and an external lock with hexagon nuts.

#### Optionale Ausrüstung

Dismantling pieces can be upgraded to a lockable version with additional inner hexagon nuts. Internal sleeves are possible for abrasive media.

<b>Nominal diameter</b>	DN 40 to DN 1000
<b>Standard design</b>	Bellow 1.4541 or 1.4571. Connections of carbon steel. Sleeve and protective cover of carbon steel.
<b>Permissible operating data</b>	16 barg / 120 °C acc. to EJMA Higher pressures on request.
<b>Accessories</b>	Internal sleeve, external protective sleeve

With an outer protective cover underground installation is possible.

#### Versions

Other materials, nominal diameters and designs are available on request.

Technical design see type 212 (with loose flanges) or type 214 (with fixed flanges).

## Ausbaustück

### Typ 250

### Typ 251 (mit Innenleitrohr)

für PN 10 / for PN 10

Anzahl / Piece		
DN	Anzahl / Piece	Gewinde / Thread
40 - 125	4	M16
150 - 350	4	M20
400 - 500	6	M24
600 - 700	8	M27
800 - 900	10	M30
1000 - 1100	12	M33
1200	12	M36

für PN 16 / for DN 16

Anzahl / Piece		
DN	Anzahl / Piece	Gewinde / Thread
40 - 125	4	M16
150 - 200	4	M20
250 - 350	4	M24
400 - 450	4	M27
500	6	M30
600 - 700	8	M33
800 - 900	12	M36
1000 - 1100	12	M39
1200	12	M45



## Axial expansion joint

Type 250

Type 251 (with internal sleeve)

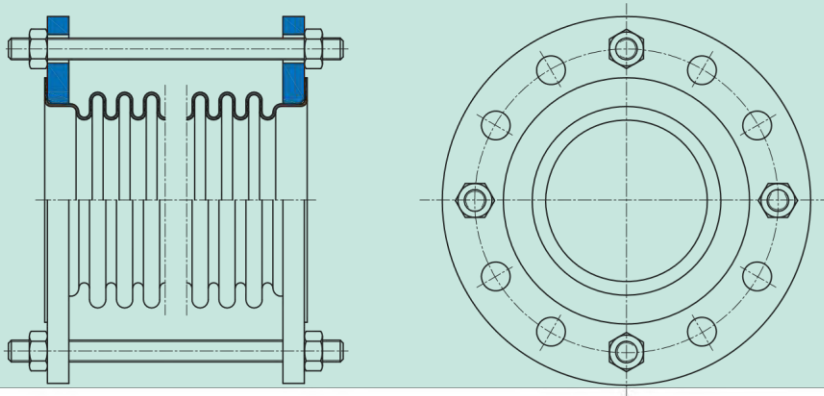



## Vibration absorber



### Schwingungskompensator mit Festflanschen

### with fixed flanges

#### Typ 260

#### Type 260

#### Typ 261 (mit Innenleitrohr)

#### Typ 261 (with internal sleeve)

Der Typ 260 ist ein mehrlagiger Schwingungskompensator mit Festflanschen. Die Verspannung ist auf die Anschlüsse aufgeschweißt.

Er ist speziell konzipiert zur Reduzierung von Schwingungen im System und zur Geräuschreduzierung.

Diese Kompensator lässt nur kleine axiale und laterale Bewegungen zu und ist ausgelegt auf mindestens 1 Mio. Lastwechsel.

#### Ausführung

Andere Nennweiten, Baulängen zur Aufnahme höherer Schwingungsamplituden auf Anfrage.

Type 260 is a multi-layer vibration absorber with fixed flanges.  
This expansion joint has tie rods.

It is designed specifically to reduce vibrations in the system and noise.

This absorber only allows small axial and lateral movements and is designed for minimum 1 million load cycles.

#### Ausführung

Other nominal diameters and lengths to accommodate higher vibration amplitudes on request.



**Einsatzbeispiele** Pumpen, Kompressoren, Brenner, Hausinstallation, Industrieanlagen, Heizungen, Klimaanlage, Ventilatoren, Wärmerückgewinnungsanlagen, Gas-, Wasser- und Abwasseranlagen

**Standardmäßiger Aufbau** Mehrlagiger Wellrohrbalg aus 1.4571, Flanschen aus P265GH, Verspannung Stahl verzinkt, NBR-Gummibuchsen (bis 100 °C) oder Edelstahldrahtkissen (ab 100 °C)

**Nennweite (Standard)** Von DN 40 bis DN 400 für eine allseitige Schwingungsaufnahme von 1 mm.

**Zulässige Betriebsdaten** 16 barg / 120 °C  
(Standard) Höhere Drücke und Temperaturen auf Anfrage.

**Application examples** Pumps, compressors, burners, domestic installation, industrial plants, heating systems, air-conditioning systems, ventilators, heat recovery systems, gas, water and sewerage systems

**Standard design** Multi-layer corrugated tube bellows of 1.4571, flanges of P265GH, steel galvanised tie rods, NBR rubber bushes (up to 100 °C) or stainless steel wire cushions (from 100 °C)

**Nominal diameter (standard)** From DN 40 to DN 400 for absorbing vibrations of 1 mm on all sides.

**Permissible operating data** 16 barg / 120 °C  
Higher pressures on request.

**Typ 260 Abmessungen  
Ausführung 1**

**Type 260 Specifications  
Model 1**

**Druckstufe 16 barg (PN 16)  
Design pressure 16 barg (PN 16)**

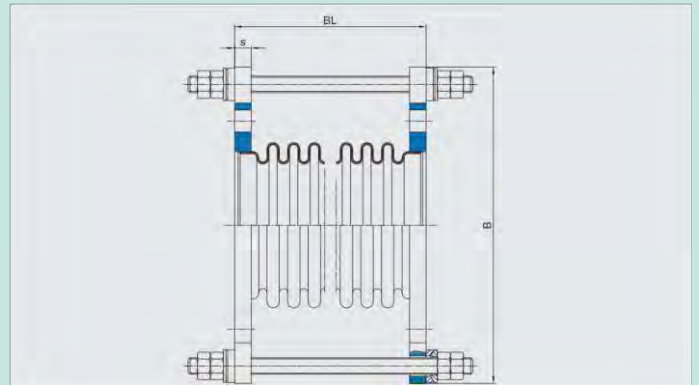

DN	Länge Length	Größte Breite Biggest width	Flansch Flanges	Bewegungsaufnahme Movement lateral	Schwingungen Vibrations alle Richtungen in all plans	Verstellmomentrate Friction rate			Gewicht Weight	Artikel Article
	BL mm	B mm	s mm	2ΔN mm	mm	CΔ N/mm	Cp N/mm barg	Cr N/barg	kg	
50	130	251	18	11	0,5	69	0	9,9	7,6	260-16-011-0050
65	130	271	22	7	0,5	163	0	17,0	9,9	260-16-007-0065
80	130	286	22	9	0,5	163	0	28,0	11,3	260-16-009-0080
100	130	306	22	7	0,5	285	0	45,0	12,4	260-16-007-0100
125	130	336	22	8	0,5	417	0	66,0	15,2	260-16-008-0125
150	130	371	27	5	0,5	1050	0	83,0	21,0	260-16-005-0150
200	130	442	27	5	0,5	1980	0	161,0	28,1	260-16-005-0200
250	130	507	27	4	0,5	4270	0	250,0	38,9	260-16-004-0250
300	130	562	32	2	0,5	13300	0	350,0	52,0	260-16-002-0300

## Kompensator mit Losflanschen

### Typ 262

### Typ 263 (mit Innenleitrohr)

Der Typ 262 ist ein mehrlagiger Schwingungskompensator mit Losflanschen. Die Verspannung ist auf die Anschlüsse aufgeschweißt.

Er ist speziell konzipiert zur Reduzierung von Schwingungen im System und zur Geräuschreduzierung.

Diese Kompensator lässt nur kleine axiale und laterale Bewegungen zu und ist ausgelegt auf mindestens 1 Mio. Lastwechsel.

#### Ausführung

Andere Nennweiten, Baulängen zur Aufnahme höherer Schwingungsamplituden auf Anfrage.

### Vibration absorber

## Compensator with unflanging

### Type 262

### Type 263 (with internal sleeve)



Type 262 is a multi-layer vibration absorber with loose flanges. This expansion joint has tie rods. It is designed specifically to reduce vibrations in the system and noise.

This absorber only allows small axial and lateral movements and is designed for minimum 1 million load cycles.

#### Ausführung

Other nominal diameters and lengths to accommodate higher vibration amplitudes on request.

#### Einsatzbeispiele

Pumpen, Kompressoren, Brenner, Hausinstallation, Industrieanlagen, Heizungen, Klimaanlage, Ventilatoren, Wärmerückgewinnungsanlagen, Gas-, Wasser- und Abwasseranlagen

#### Standardmäßiger Aufbau

Mehrlagiger Wellrohrbalg aus 1.4571, Flanschen aus P265GH, Verspannung Stahl verzinkt, NBR-Gummibuchsen (bis 100 °C) oder Edelstahldrahtkissen (ab 100 °C)

#### Nennweite (Standard)

Von DN 40 bis DN 300 für eine allseitige Schwingungsaufnahme von 1 mm.

#### Zulässige Betriebsdaten

16 barg / 120 °C

(Standard) Höhere Drücke und Temperaturen auf Anfrage.

#### Application examples

Pumps, compressors, burners, domestic installation, industrial plants, heating systems, air-conditioning systems, ventilators, heat recovery systems, gas, water and sewerage systems

#### Standard design

Multi-layer corrugated tube bellows of 1.4571, flanges of P265GH, steel galvanised tie rods, NBR rubber bushes (up to 100 °C) or stainless steel wire cushions (from 100 °C)

#### Nominal diameter (standard)

From DN 40 to DN 300 for absorbing vibrations of 1 mm on all sides.

#### Permissible operating data

16 barg / 120 °C

Higher pressures on request.



150	130		1,0	21,0	262-16-005-0150
200	130		1,0	28,1	262-16-005-0200
250	130		1,0	38,9	262-16-004-0250
300	130		1,0	52,0	262-16-002-0300
<b>Ausführung 1</b>					

**Type 262 Specifications  
Model 1**

**Druckstufe 16 barg (PN 16)  
Design pressure 16 barg**

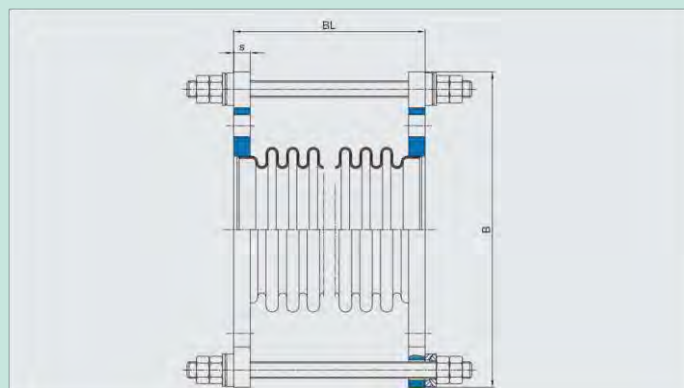

**(PN 16)**

DN	Länge Length  BL mm	Schwingungen Vibrations  alle Richtungen / in all plans  mm	Gewicht Weight  kg	Artikel Article
50	130		7,6	262-16-011-0050
65	130		9,9	262-16-007-0065
80	130		11,3	262-16-009-0080
100	130		12,4	262-16-007-0100
125	130		15,2	262-16-008-0125



## Axialkompensator mit Gewindeanschluss

### Typ 270

Durch die besondere Konstruktion des Balges in Kombination mit dem Innenleitrohr ist ein optimaler Innendurchmesser geschaffen worden, so dass kein höherer Druckverlust als bei herkömmlichen Rohrleitungen entsteht.

Durch den integrierten Bewegungsbegrenzer ist eine problemlose Aufnahme der Axialdehnung von +5 bis -45 mm möglich. Eine Überdehnung ist somit ausgeschlossen. Der Typ 270 wird einbaufertig mit weißbeschichteter Oberfläche geliefert, somit kann ohne Mehraufwand eine offene Installation im Sichtbereich durchgeführt werden.

Der Kompensator ist mit seiner Dehnungsaufnahme so ausgelegt, dass bei einer Betriebstemperatur von 70/90 °C die Dehnung von 30 m C-Stahl-Rohrleitung aufgenommen werden kann. Dies entspricht einem 10-Etagen-Gebäude.

Durch die Schlichtheit des Kompensators ist Typ 270 auch für Wohn- und Arbeitsbereiche hervorragend geeignet.

Der Typ 270 ist jedoch nicht für Geräuschkämpfung geeignet.

### Axial expansion joint with thread flanges

### Typ 270

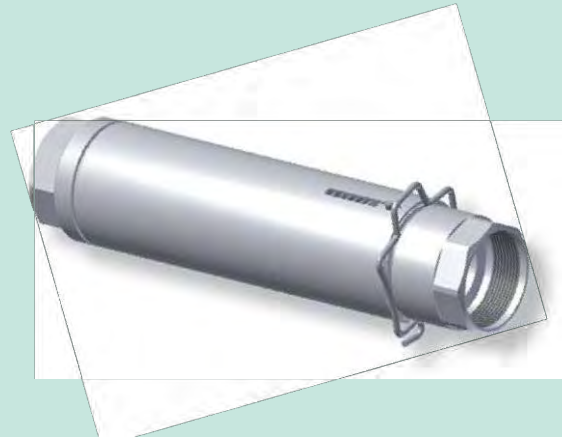

The special design of the bellows in combination with the internal sleeve provides an optimal internal diameter so that the pressure loss is not higher than with conventional pipelines.

The integrated movement limiter facilitates the absorption of axial expansion from +5 to -45 mm so that overexpansion is not possible. Type 270 is supplied ready to install with a white surface for exposed installation in a visible area without additional work and expense.

This expansion joint is capable of absorbing the expansion of a 30 metre long carbon steel pipeline at an operating temperature of 70/90 °C, which corresponds to a ten-storey building.

The simplicity of the type 270 expansion joint makes it ideal also for domestic and work areas.

Type 270 is not suitable for noise reduction however.

## Typ 270 Abmessungen

## Type 270 Specifications

Druckstufe 16 barg (PN 16)

Design pressure 16 barg (PN 16)

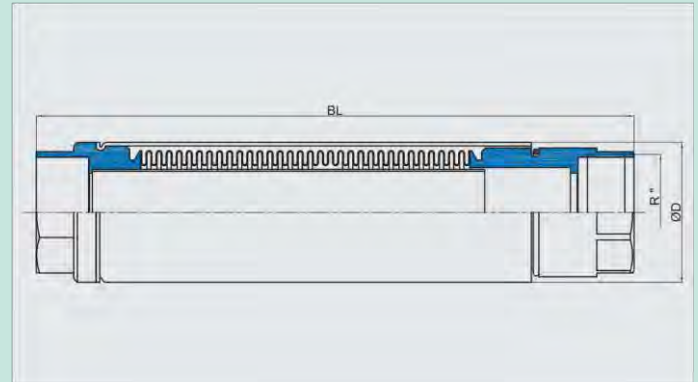

DN	Länge Length	Außendurchmesser Außendurchmesser	Bewegungsaufnahme Movement	Anschlussenden Anschlussenden		Gewicht Weight	Artikel Article
	BL mm	ØD mm	axial 2ØN mm	R"			
15	260	32,0	5/45	BSP	1/2"	0,7	2070411500
20	260	38,0	5/45	BSP	3/4"	0,7	2070112000
25	285	48,3	5/45	BSP	1"	1,0	2070412500
32	320	60,3	5/45	BSP	1 1/4"	2,0	2070413200
40	320	77,0	5/45	BSP	1 1/2"	3,0	2070414400
50	320	77,0	5/45	BSP	2"	2,6	2070415000

Weitere Abmessungen und Werkstoffe auf Anfrage.  
/ Other dimensions and materials on request.



**Einsatzbeispiele** Heizungsanlagen, Ventilations- und Warmwassersysteme in großen Gebäuden wie z. B. Krankenhäusern, Bürohochhäusern, Fabrikanlagen, Produktionsstätten

**Aufbau**

Balg aus:  
AISI 316Ti / 1.4571 Leitrohr aus:  
S 235 JRG2 (RSt 37-2),  
Anschlussenden aus:  
S235 JRG2 (RSt 37-2)  
Außenschutz aus Aluminium mit Bewegungsbegrenzer

**Zulässige Betriebsdaten**

maximale Betriebstemperatur:  
250 °C maximaler Betriebsdruck:  
16 barg  
Gewindeanschluss: BSP  
Dehnungsaufnahme:  
axial 50 mm (+5/-45 mm)

**Hinweis** Beim Einbau sollte ein Drehmomentschlüssel verwendet und Torsion vermieden werden.

**Application examples** Heating systems, ventilation and hot-water systems in large buildings, e.g. hospitals, office high-rises, manufacturing plants, production centres

**Standard design**

Bellow of:  
AISI 316Ti / 1.4571  
Sleeve of:  
S 235 JRG2 (RSt 37-2)  
Connections of:  
S235 JRG2 (RSt 37-2)  
Outer cover of aluminium with movement limiters

**Nominal diameter**

max. operating temperatures:  
250 °C max. operating pressure:  
16 bar seal threaded joint: BSP extension absorption: axial 50 mm (+5/-45)

**Note** A torque wrench should be used during installation and torsion should be avoided.

## Lateralkompensator mit Anschweißenden

### Typ 280

Der Typ 280 ist ein mehrlagiger Lateralkompensator bestehend aus einem Doppelbalg verbunden durch ein Zwischenrohr mit Anschweißenden. Er ist einseitig beweglich.

Die Verspannung ist auf die Anschlüsse aufgeschweißt.

Er ist speziell konzipiert für den Betrieb in Anlagen mit Betriebsdrücken bis 63 barg.

Dieser Kompensator lässt eine einseitige laterale Bewegungen zu.

#### Beschreibung

Neben den aufgeführten Standardbaulängen kann er speziell auf Ihre Bedürfnisse angepasst, gefertigt werden. Dieser Kompensator kann auch in anderen Werkstoffen (siehe Seite 179) gefertigt werden.

## Typ 281 (mit Innenleitrohr) Lateral expansion joint with weld ends

### Type 280

### Typ 281 (with internal sleeve)

#### Anforderungen

▫ Strömungsumlenkung/Umlenkung des Rohrleitungssystems erforderlich

#### Vorteile

- Aufnahme großer Bewegungen in laterale Richtung
- Aufnahme großer lateraler Bewegungen mit nur einem Lateralkompensator
- Verringert die auf alle Festpunkte wirkenden Lasten, da die Gelenkverspannung die Lasten aufnehmen, ohne die axiale Druckkraft auf die Festpunkte zu übertragen



Type 280 is a multi-layer lateral expansion joint consisting of a double bellows connected by an intermediate pipe with weld ends. It is hinged on one side.

This expansion joint has a hinge construction.

It is designed specifically for operation in installations with operating pressures up to 63 barg.

Type 280 allows large lateral movements.

#### **Description**

In addition to the given standard lengths, other lengths are available to meet specific requirements. This expansion joint can also be produced in other materials (see page 179).

#### **Requirements**

- Flow deflection/redirection of pipe system necessary

#### **Advantages**

- Suitable for movements in all lateral directions
- For large lateral movements with only one lateral expansion joint
- Reduces loads exerted on all fixed points, since the tie rods absorb the loads without transmitting the axial compressive force to the fixed points

## Lateralkompensator Anschweißenden joint with weld ends

### Typ 280

### Typ 281 (mit Innenleitrohr)

## Lateral expansion mit

### Typ 280

### Type 281 (with internal sleeve)

<b>Einsatzbeispiele</b>	U- und Z-Rohrleitungssysteme
<b>Standardmäßiger Aufbau</b>	Mehrlagiger Wellrohrbalg aus 1.4541 mit Zwischenrohr. Anschweißenden und Verspannungen sind aus C-Stahl. Ab einer Anschweißendendicke von 3,5 mm ist das Anschweißende montagefertig gefast.
<b>Zulässige Betriebsdaten (Standard)</b>	16 barg / 120 °C Höhere Drücke und Temperaturen auf Anfrage.
<b>Zubehör</b>	Innenleitrohr
<b>Hinweis</b>	Bei Verwendung von Leitrohren vermindert sich der Balgquerschnitt. Bitte beachten Sie bei Ihrer Planung die Medienverträglichkeit der zu verwendenden Kompensatorenmaterialien.

<b>Application examples</b>	U and Z piping systems
<b>Standard design</b>	Multi-layer corrugated tube bellows of 1.4541 with intermediate pipe. Weld ends and tie rods of carbon steel. From a weld end thickness of 3.5 mm, these parts are bevelled ready for installation.
<b>Permissible operating data</b>	16 barg / 120 °C. Higher pressures and temperatures on request.
<b>Accessories</b>	Internal sleeve
<b>Note</b>	Using internal sleeves will reduce the bellows cross-section. To be noted is that the media compatibility of the expansion joint material to be used should be taken into account in the planning phase.

Typ 280 Abmessungen

Type 280 Specifications

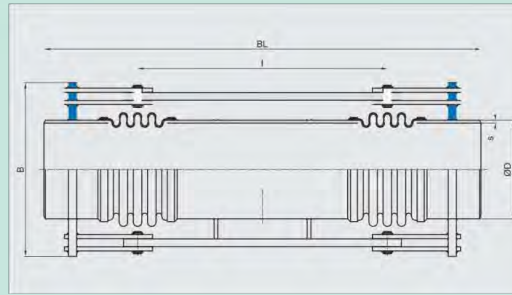

Druckstufe 6 barg (PN 6)  
Design pressure 6 barg (PN 6)

DN	Länge	Größte Breite Biggest width	Balg Bellow	Anschweißenden Weld ends		Bewegungsaufnahme Movement lateral	Verstellmomentrate Friction rate			Gewicht Weight kg	Artikel Article
	BL mm			B mm	l* mm		ØD mm	s mm	2λN mm		
600	815	840	397	610	6,0	61	399,0	6,6	417,0	188	280-06-061-0600
600	1075	840	657	610	6,0	101	148,0	2,4	252,0	216	280-06-101-0600
600	1395	840	977	610	6,0	150	68,0	1,1	170,0	251	280-06-150-0600
600	1715	840	1297	610	6,0	200	39,0	0,7	128,0	286	280-06-200-0600
700	990	945	515	711	6,0	90	155,0	8,3	433,0	228	280-06-090-0700
700	1050	945	575	711	6,0	100	125,0	6,7	388,0	236	280-06-100-0700
700	1340	945	865	711	6,0	151	56,0	3,0	258,0	274	280-06-151-0700
700	1620	945	1145	711	6,0	200	32,0	1,7	195,0	310	280-06-200-0700
800	990	1055	535	813	8,0	95	207,0	8,2	783,0	367	280-06-095-0800
800	1020	1055	565	813	8,0	101	186,0	7,3	742,0	373	280-06-101-0800
800	1300	1055	845	813	8,0	151	84,0	3,3	496,0	428	280-06-151-0800
800	1580	1055	1125	813	8,0	201	48,0	1,9	373,0	484	280-06-201-0800
900	1050	1190	585	914	8,0	91	251,0	8,5	899,0	440	280-06-091-0900
900	1110	1190	645	914	8,0	101	207,0	7,0	815,0	453	280-06-101-0900
900	1430	1190	965	914	8,0	151	93,0	3,2	545,0	526	280-06-151-0900
900	1750	1190	1285	914	8,0	201	53,0	1,8	410,0	599	280-06-201-0900
1000	1120	1265	635	1016	8,0	88	297,0	8,9	1625,0	547	280-06-088-1000
1000	1210	1265	725	1016	8,0	100	229,0	6,9	1423,0	570	280-06-100-1000
1000	1570	1265	1085	1016	8,0	150	103,0	3,1	951,0	660	280-06-150-1000
1000	1930	1265	1445	1016	8,0	200	58,0	1,8	714,0	750	280-06-200-1000
1100	1235	1415	718	1120	8,0	101	305,0	11,0	1090,0	662	280-06-101-1100
1100	1235	1415	718	1120	8,0	101	305,0	11,0	1090,0	662	280-06-101-1100
1100	1585	1415	1068	1120	8,0	150	139,0	4,8	733,0	759	280-06-150-1100
1100	1935	1415	1418	1120	8,0	200	79,0	2,8	552,0	856	280-06-200-1100
1200	1355	1465	802	1220	8,0	104	302,0	9,6	1743,0	752	280-06-104-1200
1200	1355	1465	802	1220	8,0	104	302,0	9,6	1743,0	752	280-06-104-1200
1200	1705	1465	1152	1220	8,0	150	147,0	4,7	1214,0	858	280-06-150-1200
1200	2085	1465	1532	1220	8,0	200	84,0	2,7	913,0	974	280-06-200-1200
1300	1305	1580	792	1320	8,0	67	703,0	7,2	2087,0	880	280-06-067-1300
1300	1410	1580	855	1320	8,0	138	262,0	11,0	1946,0	910	280-06-138-1300
1300	1495	1580	938	1320	8,0	151	219,0	8,6	1774,0	937	280-06-151-1300
1300	1795	1580	1238	1320	8,0	200	126,0	4,9	1344,0	1038	280-06-200-1300
1400	1355	1700	842	1420	8,0	67	767,0	7,3	2271,0	1102	280-06-067-1400
1400	1460	1700	905	1420	8,0	136	289,0	11,0	2126,0	1137	280-06-136-1400
1400	1565	1700	1008	1420	8,0	151	234,0	8,6	1909,0	1175	280-06-151-1400
1400	1890	1700	1335	1420	8,0	201	134,0	4,9	1441,0	1298	280-06-201-1400
1500	1425	1840	892	1520	8,0	66	835,0	7,5	2455,0	1252	280-06-066-1500
1500	1530	1840	955	1520	8,0	132	330,0	11,0	2304,0	1289	280-06-132-1500
1500	1665	1840	1088	1520	8,0	150	254,0	8,4	2024,0	1342	280-06-150-1500
1500	2020	1840	1445	1520	8,0	200	145,0	4,7	1523,0	1486	280-06-200-1500
1600	1475	1945	942	1620	8,0	65	904,0	7,6	2639,0	1397	280-06-065-1600
1600	1580	1945	1005	1620	8,0	126	388,0	11,0	2483,0	1436	280-06-126-1600
1600	1770	1945	1195	1620	8,0	150	275,0	7,8	2088,0	1517	280-06-150-1600
1600	2170	1945	1595	1620	8,0	200	155,0	4,4	1565,0	1685	280-06-200-1600

## Typ 280 Abmessungen Type 280 Specifications

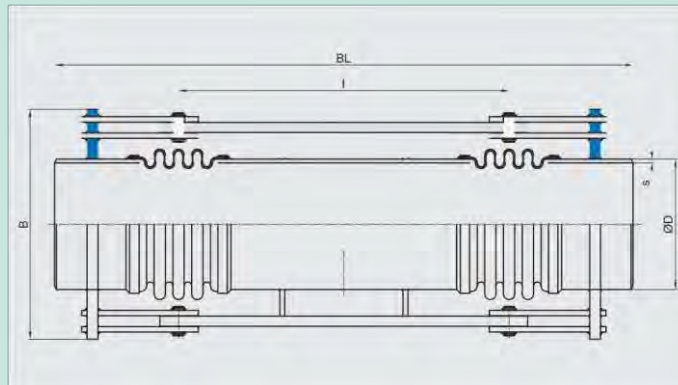

1700	1560	2040	995	1720	8,0	55	1720,0	7,9	3522,0	1691	<b>280-06-055-1700</b>
1700	1640	2040	1060	1720	8,0	116	630,0	12,0	3322,0	1728	<b>280-06-116-1700</b>
1700	1940	2040	1360	1720	8,0	150	384,0	7,0	2590,0	1868	<b>280-06-150-1700</b>
1700	2400	2040	1820	1720	8,0	200	215,0	3,9	1935,0	2082	<b>280-06-200-1700</b>

\*I = Mittenabstand / center distance

Kleinere Nennweiten siehe Typ 220. / For smaller nominal sizes see type 220.

Weitere Abmessungen und Werkstoffe auf Anfrage. /

Other dimensions and materials on request.

### Druckstufe 6 barg (PN 6)

### Design pressure 6 barg (PN 6)

DN	Länge Length	Größte Breite Biggest width	Balg Bellow	Anschweißenden Weld ends		Bewegungsaufnahme Movement lateral	Verstellmomentrate Friction rate			Gewicht Weight kg	Artikel Article
	BL mm	B mm	I* mm	ØD mm	s mm	2λN mm	Cλ N/mm	Cp N/mm barg	Cr N/barg		
1800	1660	2145	1045	1820	8,0	55	1840,0	8,0	3753,0	2070	<b>280-06-055-1800</b>
1800	1730	2145	1110	1820	8,0	117	654,0	12,0	3554,0	2106	<b>280-06-117-1800</b>
1800	2040	2145	1420	1820	8,0	150	401,0	7,2	2778,0	2268	<b>280-06-150-1800</b>
1800	2510	2145	1890	1820	8,0	200	227,0	4,1	2087,0	2515	<b>280-06-200-1800</b>
1900	1820	2245	1095	1920	8,0	64	1430,0	8,1	5201,0	2368	<b>280-06-064-1900</b>

## Typ 280 Abmessungen

## Type 280 Specifications

1900	1890	2245	1160	1920	8,0	116	702,0	12,0	4917,0	2399	<b>280-06-116-1900</b>
1900	2220	2245	1490	1920	8,0	150	426,0	7,3	3828,0	2578	<b>280-06-150-1900</b>
1900	2720	2245	1990	1920	8,0	200	239,0	4,1	2866,0	2850	<b>280-06-200-1900</b>
2000	1880	2350	1145	2020	8,0	64	1520,0	8,2	5503,0	2583	<b>280-06-064-2000</b>
2000	1940	2350	1210	2020	8,0	115	750,0	13,0	5215,0	2609	<b>280-06-115-2000</b>
2000	2300	2350	1570	2020	8,0	150	446,0	7,3	4019,0	2811	<b>280-06-150-2000</b>
2000	2820	2350	2090	2020	8,0	200	252,0	4,1	3019,0	3104	<b>280-06-200-2000</b>

\*l = Mittenabstand / center distance

Kleinere Nennweiten siehe Typ 220. / For smaller nominal sizes see type 220.

Weitere Abmessungen und Werkstoffe auf Anfrage. /

Other dimensions and materials on request.

## Typ 280 Abmessungen

## Type 280 Specifications

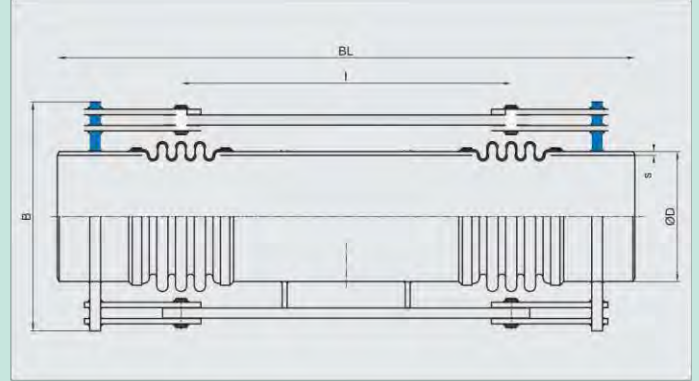

### Druckstufe 10 barg (PN 10) Design pressure 10 barg (PN 10)

DN	Länge	Größte Breite Biggest width	Balg Bellows	Anschweißenden Weld ends		Bewegungsaufnahme Movement lateral	Verstellmomentrate Friction rate			Gewicht Weight	Artikel Article
	BL			B	l*		ØD	s	2ΔN		
	mm	mm	mm	mm	mm	mm	N/mm	N/mm barg	N/barg	kg	
600	825	845	397	610	8,0	57	399,0	6,6	595,0	261	280-10-057-0600
600	1125	845	697	610	8,0	101	132,0	2,2	339,0	309	280-10-101-0600
600	1465	845	1037	610	8,0	150	60,0	1,0	228,0	363	280-10-150-0600
600	1805	845	1377	610	8,0	200	34,0	0,6	172,0	416	280-10-200-0600
700	960	980	490	711	8,0	90	270,0	7,8	656,0	365	280-10-090-0700
700	1010	980	540	711	8,0	100	224,0	6,4	595,0	375	280-10-100-0700
700	1280	980	810	711	8,0	150	101,0	2,9	397,0	425	280-10-150-0700
700	1550	980	1080	711	8,0	200	57,0	1,6	298,0	476	280-10-200-0700
800	1040	1095	540	813	8,0	82	373,0	8,4	780,0	463	280-10-082-0800
800	1160	1095	660	813	8,0	101	251,0	5,6	638,0	490	280-10-101-0800
800	1480	1095	980	813	8,0	150	115,0	2,6	430,0	559	280-10-150-0800
800	1810	1095	1310	813	8,0	200	65,0	1,5	322,0	631	280-10-200-0800
900	1120	1190	595	914	8,0	88	484,0	9,0	1425,0	602	280-10-088-0900
900	1200	1190	675	914	8,0	100	377,0	7,0	1256,0	622	280-10-100-0900
900	1540	1190	1015	914	8,0	151	168,0	3,1	835,0	705	280-10-151-0900
900	1870	1190	1345	914	8,0	200	96,0	1,8	630,0	785	280-10-200-0900
1000	1190	1320	645	1016	8,0	86	551,0	9,4	1612,0	759	280-10-086-1000
1000	1290	1320	745	1016	8,0	100	414,0	7,1	1396,0	787	280-10-100-1000
1000	1660	1320	1115	1016	8,0	150	186,0	3,2	933,0	889	280-10-150-1000
1000	2030	1320	1485	1016	8,0	200	106,0	1,8	700,0	991	280-10-200-1000
1100	1235	1430	663	1120	8,0	67	952,0	8,3	2395,0	955	280-10-067-1100
1100	1555	1430	983	1120	8,0	100	435,0	3,8	1615,0	1056	280-10-100-1100
1100	2045	1430	1473	1120	8,0	150	194,0	1,7	1078,0	1211	280-10-150-1100
1100	2525	1430	1953	1120	8,0	200	111,0	1,0	813,0	1363	280-10-200-1100
1200	1295	1525	748	1220	8,0	75	802,0	7,1	1907,0	1021	280-10-075-1200
1200	1540	1525	990	1220	8,0	100	456,0	4,2	1440,0	1104	280-10-100-1200
1200	2025	1525	1478	1220	8,0	150	205,0	1,9	965,0	1271	280-10-150-1200
1200	2525	1525	1978	1220	8,0	200	115,0	1,1	721,0	1442	280-10-200-1200
1300	1375	1645	798	1320	8,0	74	882,0	7,3	2612,0	1316	280-10-074-1300
1300	1645	1645	1068	1320	8,0	100	493,0	4,1	1952,0	1421	280-10-100-1300
1300	2185	1645	1608	1320	8,0	150	217,0	1,8	1297,0	1630	280-10-150-1300
1300	2715	1645	2138	1320	8,0	200	123,0	1,1	975,0	1836	280-10-200-1300
1400	1510	1745	850	1420	8,0	71	1040,0	7,7	2839,0	1651	280-10-071-1400
1400	1630	1745	950	1420	8,0	154	410,0	13,0	2541,0	1702	280-10-154-1400
1400	1630	1745	950	1420	8,0	154	410,0	13,0	2541,0	1702	280-10-154-1400
1400	1910	1745	1230	1420	8,0	199	246,0	7,3	1962,0	1826	280-10-199-1400

\*l = Mittenabstand / center distance

Kleinere Nennweiten siehe Typ 220. / For smaller nominal sizes see type 220.

Weitere Abmessungen und Werkstoffe auf Anfrage. /  
Other dimensions and materials on request.

## Typ 280 Abmessungen

## Type 280 Specifications

**Druckstufe 16 barg (PN 16)**  
**Design pressure 16 barg (PN 16)**

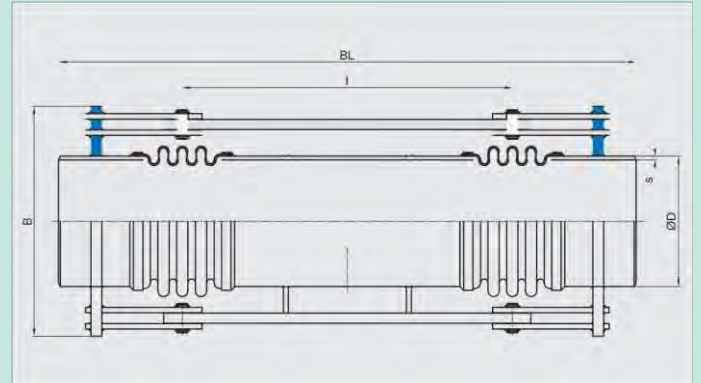

DN	Länge	Größte Breite	Balg	Anschweißenden		Bewegungsaufnahme	Verstellmomentrate			Gewicht	Artikel
	Length	Biggest width	Bellow	Weld ends	Movement		Friction rate				
	BL	B	I*	ØD	s	2ΔN	Cλ	Cp	Cr	kg	
	mm	mm	mm	mm	mm	mm	N/mm	N/mm barg	N/barg		
500	845	735	408	508	8,8	50	703,0	4,0	417,0	242	280-16-050-0500
500	995	735	472	508	8,8	107	281,0	5,9	359,0	258	280-16-107-0500
500	1185	735	662	508	8,8	150	147,0	3,0	256,0	286	280-16-150-0500
500	1405	735	882	508	8,8	200	84,0	1,7	192,0	319	280-16-200-0500
600	885	870	402	610	8,0	54	683,0	6,9	601,0	329	280-16-054-0600
600	1225	870	742	610	8,0	101	204,0	2,1	326,0	386	280-16-101-0600
600	1585	870	1102	610	8,0	150	93,0	1,0	220,0	447	280-16-150-0600
600	1955	870	1472	610	8,0	200	53,0	0,6	165,0	509	280-16-200-0600
700	985	985	463	711	8,0	61	732,0	7,1	1140,0	473	280-16-061-0700
700	1085	985	532	711	8,0	100	384,0	8,9	986,0	488	280-16-100-0700
700	1355	985	802	711	8,0	151	173,0	4,0	654,0	543	280-16-151-0700
700	1615	985	1062	711	8,0	200	99,0	2,3	494,0	596	280-16-200-0700
800	1085	1115	547	813	8,0	73	751,0	8,7	1234,0	618	280-16-073-0800
800	1285	1115	747	813	8,0	100	407,0	4,7	904,0	665	280-16-100-0800
800	1665	1115	1127	813	8,0	151	180,0	2,1	600,0	755	280-16-151-0800
800	2035	1115	1497	813	8,0	200	103,0	1,2	452,0	843	280-16-200-0800
900	1145	1250	602	914	8,0	65	1320,0	9,3	1407,0	826	280-16-065-0900
900	1285	1250	673	914	8,0	116	518,0	12,0	1269,0	874	280-16-116-0900
900	1485	1250	873	914	8,0	151	312,0	6,7	978,0	931	280-16-151-0900
900	1765	1250	1153	914	8,0	199	181,0	3,8	741,0	1010	280-16-199-0900
1000	1265	1370	652	1016	8,0	62	1580,0	9,7	1990,0	1124	280-16-062-1000



## Typ 280 Abmessungen

## Type 280 Specifications

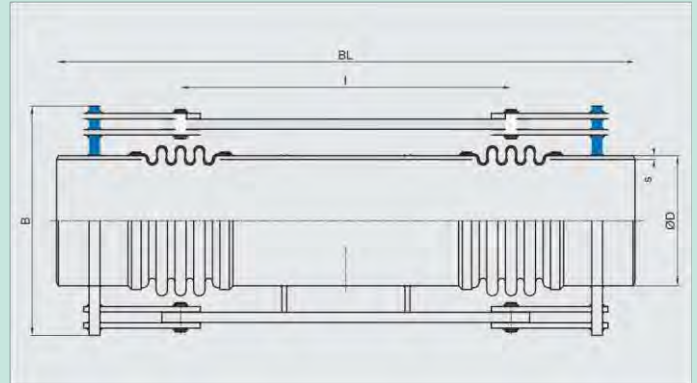

1000	1375	1370	723	1016	8,0	117	604,0	12,0	1809,0	1171	<b>280-16-117-1000</b>
1000	1575	1370	923	1016	8,0	150	374,0	7,3	1417,0	1236	<b>280-16-150-1000</b>
1000	1885	1370	1233	1016	8,0	201	212,0	4,1	1061,0	1338	<b>280-16-201-1000</b>

\*l = Mittenabstand / center distance

Kleinere Nennweiten siehe Typ 220. / For smaller nominal sizes see type 220.

Weitere Abmessungen und Werkstoffe auf Anfrage. /

Other dimensions and materials on request.

### Druckstufe 25 barg (PN 25)

### Design pressure 25 barg (PN 25)

DN	Länge	Größte Breite Biggest width	Balg Bellow	Anschweißenden Weld ends		Bewegungsaufnahme Movement lateral	Verstellmomentrate Friction rate			Gewicht Weight	Artikel Article
	BL mm			B mm	l* mm		ØD mm	s mm	2λN mm		
400	840	625	390	406,4	8,8	59	297,0	2,8	273,0	208,0	<b>280-25-059-0400</b>
400	1110	625	660	406,4	8,8	101	105,0	1,0	161,0	242,0	<b>280-25-101-0400</b>
400	1430	625	980	406,4	8,8	150	48,0	0,5	109,0	282,0	<b>280-25-150-0400</b>
400	1760	625	1310	406,4	8,8	200	27,0	0,3	82,0	324,0	<b>280-25-200-0400</b>
450	935	715	487	457,0	8,8	50	365,0	1,8	280,0	280,0	<b>280-25-050-0450</b>
450	1425	715	977	457,0	8,8	100	92,0	0,5	140,0	352,0	<b>280-25-100-0450</b>
450	1905	715	1457	457,0	8,8	149	42,0	0,2	94,0	422,0	<b>280-25-149-0450</b>
450	2395	715	1947	457,0	8,8	200	24,0	0,2	70,0	494,0	<b>280-25-200-0450</b>
500	895	775	428	508,0	8,8	50	639,0	3,7	398,0	316,0	<b>280-25-050-0500</b>
500	1325	775	858	508,0	8,8	100	161,0	0,9	199,0	388,0	<b>280-25-100-0500</b>
500	1745	775	1278	508,0	8,8	150	73,0	0,5	133,0	458,0	<b>280-25-150-0500</b>
500	2175	775	1708	508,0	8,8	200	41,0	0,3	100,0	530,0	<b>280-25-200-0500</b>
600	1015	890	468	610,0	10,0	50	1130,0	5,4	832,0	491,0	<b>280-25-050-0600</b>
600	1175	890	578	610,0	10,0	100	399,0	5,8	676,0	524,0	<b>280-25-100-0600</b>
600	1465	890	868	610,0	10,0	150	180,0	2,6	450,0	589,0	<b>280-25-150-0600</b>
600	1755	890	1158	610,0	10,0	200	102,0	1,5	338,0	655,0	<b>280-25-200-0600</b>
700	1025	1045	468	711,0	10,0	50	1480,0	7,3	1134,0	689,0	<b>280-25-050-0700</b>
700	1285	1045	683	711,0	10,0	100	598,0	5,7	768,0	753,0	<b>280-25-100-0700</b>
700	1625	1045	1023	711,0	10,0	150	270,0	2,6	513,0	847,0	<b>280-25-150-0700</b>
700	1965	1045	1363	711,0	10,0	201	153,0	1,5	385,0	941,0	<b>280-25-201-0700</b>

\*l = Mittenabstand / center distance

Kleinere Nennweiten siehe Typ 220. / For smaller nominal sizes see type 220.

Weitere Abmessungen und Werkstoffe auf Anfrage. /

Other dimensions and materials on request.

## Typ 280 Abmessungen

## Type 280 Specifications

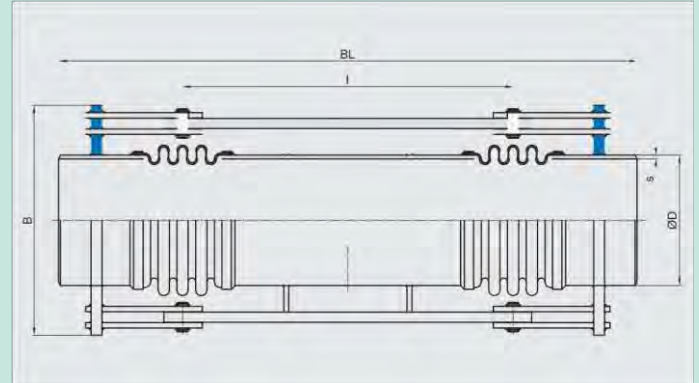

**Druckstufe 40 barg (PN 40)**  
Design pressure 40 barg (PN 40)

## Typ 280 Abmessungen

## Type 280 Specifications

DN	Länge Length	Größte Breite Biggest width	Balg Bellow	Anschweißenden Weld ends		Bewegungsaufnahme Movement	Verstellmomentrate Friction rate			Gewicht Weight	Artikel Article
	BL mm	B mm	l* mm	ØD mm	s mm	lateral 2λN mm	Cλ N/mm	Cp N/mm barg	Cr N/barg		
300	930	580	425	323,9	8,0	50	546,0	1,5	158,0	252,0	280-40-050-0300
300	1360	580	855	323,9	8,0	100	137,0	0,4	79,0	304,0	280-40-100-0300
300	1780	580	1275	323,9	8,0	150	62,0	0,2	53,0	355,0	280-40-150-0300
300	2200	580	1695	323,9	8,0	200	35,0	0,1	40,0	406,0	280-40-200-0300
350	895	600	398	355,6	8,0	60	314,0	2,3	204,0	216,0	280-40-060-0350
350	1165	600	668	355,6	8,0	100	113,0	0,8	122,0	248,0	280-40-100-0350
350	1495	600	998	355,6	8,0	150	51,0	0,4	82,0	286,0	280-40-150-0350
350	1825	600	1328	355,6	8,0	200	29,0	0,2	61,0	325,0	280-40-200-0350
400	940	670	420	406,4	10,0	69	383,0	3,3	254,0	295,0	280-40-069-0400
400	1130	670	610	406,4	10,0	100	184,0	1,6	175,0	325,0	280-40-100-0400
400	1440	670	920	406,4	10,0	151	82,0	0,7	116,0	373,0	280-40-151-0400
400	1740	670	1220	406,4	10,0	201	47,0	0,4	88,0	420,0	280-40-201-0400
450	1005	745	457	457,0	10,0	50	692,0	2,9	475,0	415,0	280-40-050-0450
450	1465	745	917	457,0	10,0	101	174,0	0,8	237,0	501,0	280-40-101-0450
450	1915	745	1367	457,0	10,0	150	79,0	0,4	159,0	586,0	280-40-150-0450
450	2365	745	1817	457,0	10,0	200	45,0	0,2	120,0	670,0	280-40-200-0450
500	1010	780	450	508,0	10,0	50	922,0	3,8	607,0	451,0	280-40-050-0500
500	1460	780	900	508,0	10,0	100	233,0	1,0	304,0	541,0	280-40-100-0500
500	1910	780	1350	508,0	10,0	150	104,0	0,5	203,0	631,0	280-40-150-0500
500	2360	780	1800	508,0	10,0	200	59,0	0,3	152,0	721,0	280-40-200-0500

\*l = Mittenabstand / center distance

Kleinere Nennweiten siehe Typ 220. / For smaller nominal sizes see type 220.

Weitere Abmessungen und Werkstoffe auf Anfrage. /

Other dimensions and materials on request.

## Druckstufe 63 barg (PN 63)

## Design pressure 63 barg (PN 63)

DN	Länge Length	Größte Breite Biggest width	Balg Bellow	Anschweißenden Weld ends		Bewegungsaufnahme Movement	Verstellmomentrate Friction rate			Gewicht Weight	Artikel Article
	BL mm	B mm	l* mm	ØD mm	s mm	lateral 2λN mm	Cλ N/mm	Cp N/mm barg	Cr N/barg		
250	855	510	393	273,0	10,0	50	338,0	1,2	123,0	193,0	280-63-050-0250
250	1245	510	783	273,0	10,0	100	86,0	0,3	62,0	238,0	280-63-100-0250
250	1635	510	1173	273,0	10,0	150	39,0	0,2	41,0	282,0	280-63-150-0250
250	2025	510	1563	273,0	10,0	201	22,0	0,1	31,0	327,0	280-63-201-0250
300	980	580	455	323,9	11,0	50	477,0	1,3	148,0	279,0	280-63-050-0300
300	1420	580	895	323,9	11,0	99	125,0	0,4	75,0	343,0	280-63-099-0300
300	1870	580	1345	323,9	11,0	150	56,0	0,2	50,0	407,0	280-63-150-0300
300	2320	580	1795	323,9	11,0	200	31,0	0,1	38,0	472,0	280-63-200-0300
350	965	610	407	355,6	12,5	52	575,0	2,4	317,0	332,0	280-63-052-0350
350	1335	610	777	355,6	12,5	100	161,0	0,7	166,0	395,0	280-63-100-0350
350	1725	610	1167	355,6	12,5	150	72,0	0,3	111,0	462,0	280-63-150-0350
350	2115	610	1557	355,6	12,5	200	41,0	0,2	83,0	528,0	280-63-200-0350
400	1015	675	458	406,4	14,2	49	981,0	2,5	373,0	438,0	280-63-049-0400
400	1475	675	918	406,4	14,2	100	248,0	0,7	186,0	537,0	280-63-100-0400
400	1935	675	1378	406,4	14,2	150	110,0	0,3	124,0	636,0	280-63-150-0400
400	2395	675	1838	406,4	14,2	200	62,0	0,2	93,0	734,0	280-63-200-0400

\*l = Mittenabstand / center distance

Kleinere Nennweiten siehe Typ 220. / For smaller nominal sizes see type 220.

Weitere Abmessungen und Werkstoffe auf Anfrage. /

Other dimensions and materials on request.



## Lateralkompensator mit Anschweißenden und Kardangelen

### Typ 286

Der Typ 286 ist ein mehrlagiger Lateralkompensator bestehend aus einem Doppelbalg verbunden durch ein Zwischenrohr mit Anschweißenden. Er ist einseitig beweglich.

Die Verspannung ist auf die Anschlüsse aufgeschweißt.

Er ist speziell konzipiert für den Betrieb in Anlagen mit Betriebsdrücken bis 63 barg.

Dieser Kompensator lässt allseitige laterale Bewegungen zu.

#### Beschreibung

Neben den aufgeführten Standardbaulängen kann die Baulänge speziell auf Ihre Bedürfnisse angepasst, gefertigt werden. Dieser Kompensator kann auch in anderen Werkstoffen (siehe Seite 179) gefertigt werden.

#### Anforderungen

▫ Strömungsumlenkung/Umlenkung des Rohrleitungssystems erforderlich

#### Vorteile

▫ Nimmt Bewegungen in verschiedenen Richtungen auf  
▫ Verringert die auf alle Festpunkte wirkenden Lasten

## Typ 287 (mit Innenleitrohr) Lateral expansion joint with weld ends and gimbal hinge

### Type 286

### Type 287 (with internal sleeve)



Type 286 is a multi-layer lateral expansion joint consisting of a double bellows connected by an intermediate pipe with weld ends.

This expansion joint has a gimbal hinge construction.

It is designed specifically for operation in installations with operating pressures up to 63 barg.

This expansion joint allows lateral movements in all directions.

#### Description

In addition to the given standard lengths, other lengths are available to meet specific requirements. This expansion joint can also be produced in other materials (see page 179).

#### Requirements

▫ Flow deflection/redirection of pipe system necessary

#### Advantages

▫ For movements in all directions  
▫ Reduces loads exerted on all fixed points

## Kardangeln

### Typ 286

### Typ 287 (mit Innenleitrohr)

**Einsatzbeispiele** Dampfanlagen, Wasser, Entwässerung etc.

#### Standardmäßiger Aufbau

Mehrlagiger Wellrohrbalg aus 1.4541 mit Zwischenrohr. Anschweißenden und die Kardangeln sind aus C-Stahl. Ab einer Anschweißendendicke von 3,5 mm ist das Anschweißende montagefertig gefast.

**Zulässige Betriebsdaten** (Standard) 16 barg / 120 °C  
Höhere Drücke auf Anfrage.

**Zubehör** Innenleitrohr

**Hinweis** Bei Verwendung von Leitrohren vermindert sich der Balgquerschnitt. Bitte beachten Sie bei Ihrer Planung die Medienverträglichkeit der zu verwendenden Kompensatorenmaterialien.

## hinge

### Type 286

### Type 287 (with internal sleeve)

**Application examples** Steam plants, water, drainage, etc.

#### Standard design

Multi-layer corrugated tube bellows of 1.4541 with intermediate pipe. Weld ends and tie rods of carbon steel. From a weld end thickness of 3.5 mm, these parts are bevelled ready for installation.

#### Permissible operating data

16 barg / 120 °C.  
Higher pressures on request.

#### Accessories

Internal sleeve

#### Note

Using internal sleeves will reduce the bellows cross-section. To be noted is that the media compatibility of the expansion joint material to be used should be taken into account in the planning phase.

## Typ 286 Abmessungen

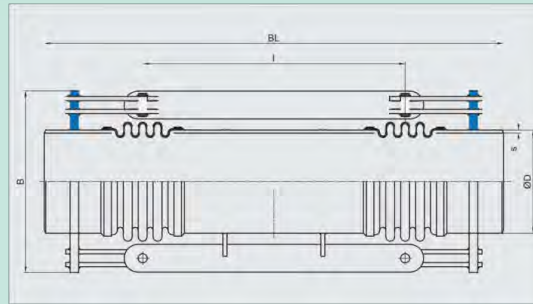

## Type 286 Specifications

**Druckstufe 6 barg (PN 6)**  
**Design pressure 6 barg (PN 6)**

DN	Länge	Größte Breite Biggest width	Balg Bellows	Anschweißenden Weld ends		Bewegungsaufnahme Movement lateral	Verstellmomentrate Friction rate			Gewicht Weight kg	Artikel Article
	Length			B	l*		ØD	s	2ΔN		
	BL	B	l*	ØD	s	2ΔN	N/mm	N/mm barg	N/barg		
600	815	840	397	610	6,0	61	399	6,6	417	196,0	286-06-061-0600
600	1075	840	657	610	6,0	101	148	2,4	252	225,0	286-06-101-0600
600	1395	840	977	610	6,0	150	68	1,1	170	260,0	286-06-150-0600
600	1715	840	1297	610	6,0	200	39	0,7	128	295,0	286-06-200-0600
700	990	950	515	711	6,0	90	155	8,3	433	237,0	286-06-090-0700
700	1050	950	575	711	6,0	100	125	6,7	388	245,0	286-06-100-0700
700	1340	950	865	711	6,0	151	56	3,0	258	282,0	286-06-151-0700
700	1620	950	1145	711	6,0	200	32	1,7	195	318,0	286-06-200-0700
800	990	1080	535	813	8,0	95	207	8,2	783	383,0	286-06-095-0800
800	1020	1080	565	813	8,0	101	186	7,3	742	389,0	286-06-101-0800
800	1300	1080	845	813	8,0	151	84	3,3	496	441,0	286-06-151-0800
800	1580	1080	1125	813	8,0	201	48	1,9	373	494,0	286-06-201-0800
900	1050	1210	585	914	8,0	91	251	8,5	899	469,0	286-06-091-0900
900	1110	1210	645	914	8,0	101	207	7,0	815	482,0	286-06-101-0900
900	1430	1210	965	914	8,0	151	93	3,2	545	555,0	286-06-151-0900
900	1750	1210	1285	914	8,0	201	53	1,8	410	628,0	286-06-201-0900
1000	1100	1300	635	1016	8,0	88	297	8,9	1625	579,0	286-06-088-1000
1000	1190	1300	725	1016	8,0	100	229	6,9	1423	602,0	286-06-100-1000
1000	1550	1300	1085	1016	8,0	150	103	3,1	951	691,0	286-06-150-1000
1000	1910	1300	1445	1016	8,0	200	58	1,8	714	781,0	286-06-200-1000
1100	1235	1440	718	1120	8,0	101	305	11,0	1090	695,0	286-06-101-1100
1100	1235	1440	718	1120	8,0	101	305	11,0	1090	695,0	286-06-101-1100
1100	1585	1440	1068	1120	8,0	150	139	4,8	733	790,0	286-06-150-1100
1100	1935	1440	1418	1120	8,0	200	79	2,8	552	886,0	286-06-200-1100
1200	1355	1495	802	1220	8,0	104	302	9,6	1743	793,0	286-06-104-1200
1200	1355	1495	802	1220	8,0	104	302	9,6	1743	793,0	286-06-104-1200
1200	1705	1495	1152	1220	8,0	150	147	4,7	1214	896,0	286-06-150-1200
1200	2085	1495	1532	1220	8,0	200	84	2,7	913	1007,0	286-06-200-1200
1300	1285	1635	792	1320	8,0	67	703	7,2	2087	947,0	286-06-067-1300
1300	1410	1655	855	1320	8,0	138	262	11,0	1946	1021,0	286-06-138-1300
1300	1495	1655	938	1320	8,0	151	219	8,6	1774	1047,0	286-06-151-1300
1300	1795	1655	1238	1320	8,0	200	126	4,9	1344	1144,0	286-06-200-1300
1400	1355	1735	842	1420	8,0	67	767	7,3	2271	1163,0	286-06-067-1400
1400	1480	1750	905	1420	8,0	136	289	11,0	2126	1241,0	286-06-136-1400
1400	1585	1750	1008	1420	8,0	151	234	8,6	1909	1278,0	286-06-151-1400
1400	1910	1750	1335	1420	8,0	201	134	4,9	1441	1397,0	286-06-201-1400
1500	1405	1860	892	1520	8,0	66	835	7,5	2455	1366,0	286-06-066-1500
1500	1530	1865	955	1520	8,0	132	330	11,0	2304	1415,0	286-06-132-1500
1500	1665	1865	1088	1520	8,0	150	254	8,4	2024	1469,0	286-06-150-1500
1500	2020	1865	1445	1520	8,0	200	145	4,7	1523	1617,0	286-06-200-1500
1600	1455	1960	942	1620	8,0	65	904	7,6	2639	1514,0	286-06-065-1600
1600	1600	1965	1005	1620	8,0	126	388	11,0	2483	1577,0	286-06-126-1600
1600	1790	1965	1195	1620	8,0	150	275	7,8	2088	1659,0	286-06-150-1600
1600	2190	1965	1595	1620	8,0	200	155	4,4	1565	1832,0	286-06-200-1600

1700	1530	2060	995	1720	8,0	55	1720	7,9	2817	1765,0	<b>286-06-055-1700</b>
1700	1660	2070	1060	1720	8,0	116	630	12,0	2658	1857,0	<b>286-06-116-1700</b>
1700	1960	2070	1360	1720	8,0	150	384	7,0	2072	1992,0	<b>286-06-150-1700</b>
1700	2420	2070	1820	1720	8,0	200	215	3,9	1548	2200,0	<b>286-06-200-1700</b>

\*l = Mittenabstand / center distance

Kleinere Nennweiten siehe Typ 220. / For smaller nominal sizes see type 220.

Weitere Abmessungen und Werkstoffe auf Anfrage. /

Other dimensions and materials on request.

## Typ 286 Abmessungen

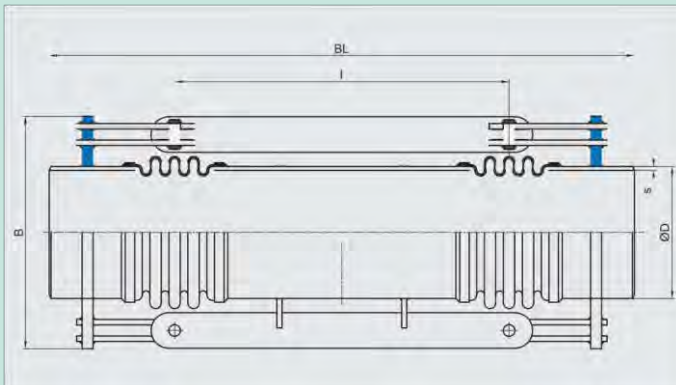

## Type 286 Specifications

**Druckstufe 6 barg (PN 6)**  
**Design pressure 6 barg (PN 6)**

DN	Länge	Größte Breite	Balg	Anschweißenden		Bewegungsaufnahme	Verstellmomentrate			Gewicht	Artikel
	Length			Biggest width	Bellow		Weld ends	Movement	Friction rate		
	BL	B	l*	ØD	s	lateral	Cλ	Cp	Cr	kg	
	mm	mm	mm	mm	mm	2λN	N/mm	N/mm barg	N/barg		
1800	1590	2165	1045	1820	8,0	55	1840	8,0	3003	2077,0	286-06-055-1800
1800	1720	2170	1110	1820	8,0	117	654	12,0	2843	2160,0	286-06-117-1800
1800	2030	2170	1420	1820	8,0	150	401	7,2	2222	2313,0	286-06-150-1800
1800	2500	2170	1890	1820	8,0	200	227	4,1	1670	2545,0	286-06-200-1800
1900	1740	2300	1095	1920	8,0	64	1430	8,1	4001	2430,0	286-06-064-1900
1900	1830	2310	1160	1920	8,0	116	702	12,0	3782	2495,0	286-06-116-1900
1900	2160	2310	1490	1920	8,0	150	426	7,3	2945	2662,0	286-06-150-1900
1900	2660	2310	1990	1920	8,0	200	239	4,1	2205	2916,0	286-06-200-1900
2000	1790	2400	1145	2020	8,0	64	1520	8,2	4233	2675,0	286-06-064-2000
2000	1880	2410	1210	2020	8,0	115	750	13,0	4012	2752,0	286-06-115-2000
2000	2240	2410	1570	2020	8,0	150	446	7,3	3092	2950,0	286-06-150-2000
2000	2760	2410	2090	2020	8,0	200	252	4,1	2322	3238,0	286-06-200-2000

\*l = Mittenabstand / center distance

Weitere Abmessungen und Werkstoffe auf Anfrage. /



## Typ 286 Abmessungen

## Type 286 Specifications

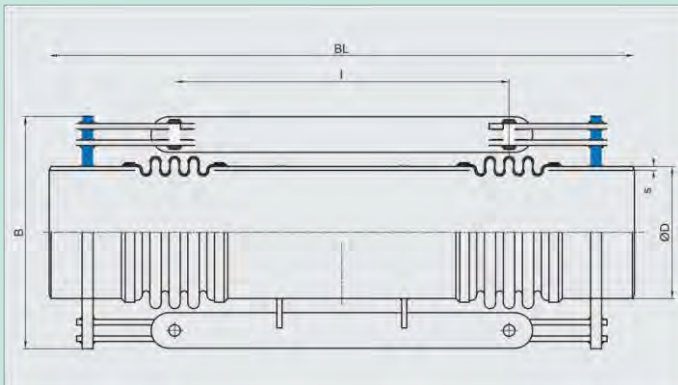

Kleinere Nennweiten siehe Typ 220. / For smaller nominal sizes see type 220.  
Other dimensions and materials on request.

**Druckstufe 10 barg (PN 10)**  
**Design pressure 10 barg (PN 10)**

DN	Länge	Größte Breite	Balg	Anschweißenden		Bewegungsaufnahme	Verstellmomentrate			Gewicht	Artikel
	Length	Biggest width	Bellow	Welde ends	Movement		Friction rate				
	BL	B	l*	ØD	s	lateral	Cλ	Cp	Cr	kg	
	mm	mm	mm	mm	mm	2ΔN	N/mm	N/mm barg	N/barg		
600	825	870	397	610	8,0	57	399	6,6	595	279,0	286-10-057-0600
600	1125	870	697	610	8,0	101	132	2,2	339	323,0	286-10-101-0600
600	1465	870	1037	610	8,0	150	60	1,0	228	374,0	286-10-150-0600
600	1805	870	1377	610	8,0	200	34	0,6	172	424,0	286-10-200-0600
700	960	1000	490	711	8,0	90	270	7,8	656	395,0	286-10-090-0700
700	1010	1000	540	711	8,0	100	224	6,4	595	404,0	286-10-100-0700
700	1280	1000	810	711	8,0	150	101	2,9	397	455,0	286-10-150-0700
700	1550	1000	1080	711	8,0	200	57	1,6	298	506,0	286-10-200-0700
800	1040	1120	540	813	8,0	82	373	8,4	780	496,0	286-10-082-0800
800	1160	1120	660	813	8,0	101	251	5,6	638	522,0	286-10-101-0800
800	1480	1120	980	813	8,0	150	115	2,6	430	590,0	286-10-150-0800
800	1810	1120	1310	813	8,0	200	65	1,5	322	660,0	286-10-200-0800
900	1100	1225	595	914	8,0	88	484	9,0	1425	625,0	286-10-088-0900
900	1180	1225	675	914	8,0	100	377	7,0	1256	643,0	286-10-100-0900
900	1520	1225	1015	914	8,0	151	168	3,1	835	722,0	286-10-151-0900
900	1850	1225	1345	914	8,0	200	96	1,8	630	799,0	286-10-200-0900
1000	1170	1365	645	1016	8,0	86	551	9,4	1612	824,0	286-10-086-1000
1000	1270	1365	745	1016	8,0	100	414	7,1	1396	852,0	286-10-100-1000
1000	1640	1365	1115	1016	8,0	150	186	3,2	933	957,0	286-10-150-1000
1000	2010	1365	1485	1016	8,0	200	106	1,8	700	1062,0	286-10-200-1000
1100	1195	1480	663	1120	8,0	65	952	8,3	2395	1046,0	286-10-065-1100
1100	1515	1480	983	1120	8,0	100	435	3,8	1615	1151,0	286-10-100-1100
1100	2005	1480	1473	1120	8,0	150	194	1,7	1078	1311,0	286-10-150-1100
1100	2485	1480	1953	1120	8,0	200	111	1,0	813	1467,0	286-10-200-1100
1200	1315	1570	748	1220	8,0	75	802	7,1	1907	1164,0	286-10-075-1200
1200	1560	1570	990	1220	8,0	100	456	4,2	1440	1244,0	286-10-100-1200
1200	2045	1570	1478	1220	8,0	150	205	1,9	965	1405,0	286-10-150-1200
1200	2545	1570	1978	1220	8,0	200	115	1,1	721	1571,0	286-10-200-1200
1300	1375	1670	798	1320	8,0	74	882	7,3	2090	1418,0	286-10-074-1300

## Typ 286 Abmessungen

## Type 286 Specifications

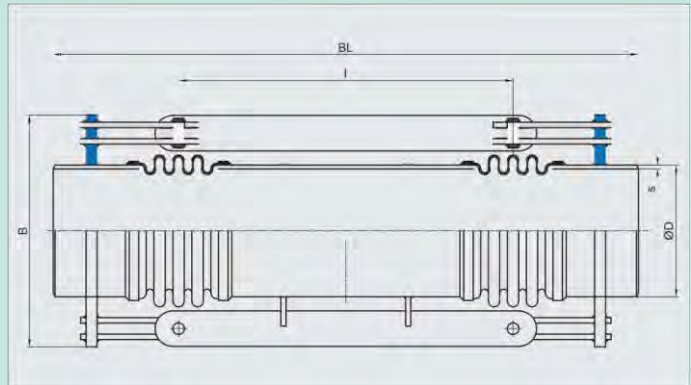

1300	1645	1670	1068	1320	8,0	100	493	4,1	1562	1519,0	286-10-100-1300
1300	2185	1670	1608	1320	8,0	150	217	1,8	1037	1720,0	286-10-150-1300
1300	2715	1670	2138	1320	8,0	200	123	1,1	780	1918,0	286-10-200-1300
1400	1450	1770	850	1420	8,0	71	1040	7,7	2271	1683,0	286-10-071-1400
1400	1630	1780	950	1420	8,0	154	410	13,0	2033	1783,0	286-10-154-1400
1400	1630	1780	950	1420	8,0	154	410	13,0	2033	1783,0	286-10-154-1400
1400	1910	1780	1230	1420	8,0	199	246	7,3	1570	1899,0	286-10-199-1400

\*I = Mittenabstand / center distance

Kleinere Nennweiten siehe Typ 220. / For smaller nominal sizes see type 220.

Weitere Abmessungen und Werkstoffe auf Anfrage. /

Other dimensions and materials on request.

### Druckstufe 16 barg (PN 16)

### Design pressure 16 barg (PN 16)

DN	Länge	Größte Breite Biggest width	Balg Bellow	Anschweißenden Weld ends		Bewegungsaufnahme Movement	Verstellmomentrate Friction rate			Gewicht Weight	Artikel Article
	BL			B	I*		ØD	s	2ΔN		
	mm	mm	mm	mm	mm	mm	N/mm	N/mm barg	N/barg	kg	
500	845	765	408	508	8,8	50	703	4,0	417	256,0	286-16-050-0500
500	995	775	472	508	8,8	107	281	5,9	359	276,0	286-16-107-0500
500	1185	775	662	508	8,8	150	147	3,0	256	302,0	286-16-150-0500
500	1405	775	882	508	8,8	200	84	1,7	192	332,0	286-16-200-0500
600	885	890	402	610	8,0	54	683	6,9	601	359,0	286-16-054-0600
600	1225	890	742	610	8,0	101	204	2,1	326	417,0	286-16-101-0600
600	1585	890	1102	610	8,0	150	93	1,0	220	477,0	286-16-150-0600
600	1955	890	1472	610	8,0	200	53	0,6	165	539,0	286-16-200-0600
700	945	1025	463	711	8,0	61	732	7,1	1140	514,0	286-16-061-0700
700	1085	1030	532	711	8,0	100	384	8,9	986	541,0	286-16-100-0700
700	1355	1030	802	711	8,0	151	173	4,0	654	593,0	286-16-151-0700
700	1615	1030	1062	711	8,0	200	99	2,3	494	643,0	286-16-200-0700
800	1085	1165	547	813	8,0	73	751	8,7	1234	699,0	286-16-073-0800
800	1285	1165	747	813	8,0	100	407	4,7	904	748,0	286-16-100-0800
800	1665	1165	1127	813	8,0	151	180	2,1	600	841,0	286-16-151-0800
800	2035	1165	1497	813	8,0	200	103	1,2	452	931,0	286-16-200-0800
900	1165	1285	602	914	8,0	65	1320	9,3	1407	928,0	286-16-065-0900
900	1285	1300	673	914	8,0	116	518	12,0	1269	997,0	286-16-116-0900

## Typ 286 Abmessungen

## Type 286 Specifications

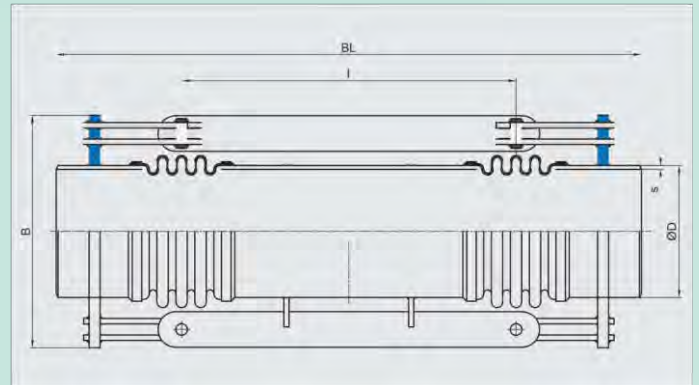

900	1485	1300	873	914	8,0	151	312	6,7	978	1051,0	<b>286-16-151-0900</b>
900	1765	1300	1153	914	8,0	199	181	3,8	741	1127,0	<b>286-16-199-0900</b>
1000	1235	1390	652	1016	8,0	62	1580	9,7	1592	1208,0	<b>286-16-062-1000</b>
1000	1375	1400	723	1016	8,0	117	604	12,0	1448	1252,0	<b>286-16-117-1000</b>
1000	1575	1400	923	1016	8,0	150	374	7,3	1134	1314,0	<b>286-16-150-1000</b>
1000	1885	1400	1233	1016	8,0	201	212	4,1	849	1411,0	<b>286-16-201-1000</b>

\*I = Mittenabstand / center distance

Kleinere Nennweiten siehe Typ 220. / For smaller nominal sizes see type 220.

Weitere Abmessungen und Werkstoffe auf Anfrage. /

Other dimensions and materials on request.

## Druckstufe 25 barg (PN 25)

## Design pressure 25 barg (PN 25)

DN	Länge	Größte Breite Biggest width	Balg Bellows	Anschweißenden Weld ends		Bewegungsaufnahme Movement lateral	Verstellmomentrate Friction rate			Gewicht Weight	Artikel Article
	BL mm			B mm	I* mm		ØD mm	s mm	2AN mm		
400	840	650	390	406,4	8,8	59	297	2,8	273	226,0	<b>286-25-059-0400</b>
400	1110	650	660	406,4	8,8	101	105	1,0	161	257,0	<b>286-25-101-0400</b>
400	1430	650	980	406,4	8,8	150	48	0,5	109	294,0	<b>286-25-150-0400</b>
400	1760	650	1310	406,4	8,8	200	27	0,3	82	333,0	<b>286-25-200-0400</b>
450	935	735	487	457,0	8,8	50	365	1,8	280	310,0	<b>286-25-050-0450</b>
450	1425	735	977	457,0	8,8	100	92	0,5	140	382,0	<b>286-25-100-0450</b>
450	1905	735	1457	457,0	8,8	149	42	0,2	94	452,0	<b>286-25-149-0450</b>
450	2395	735	1947	457,0	8,8	200	24	0,2	70	524,0	<b>286-25-200-0450</b>
500	895	805	428	508,0	8,8	50	639	3,7	398	346,0	<b>286-25-050-0500</b>

## Typ 286 Abmessungen

## Type 286 Specifications

500	1325	805	858	508,0	8,8	100	161	0,9	199	416,0	<b>286-25-100-0500</b>
500	1745	805	1278	508,0	8,8	150	73	0,5	133	484,0	<b>286-25-150-0500</b>
500	2175	805	1708	508,0	8,8	200	41	0,3	100	554,0	<b>286-25-200-0500</b>
600	995	955	468	610,0	10,0	50	1130	5,4	832	554,0	<b>286-25-050-0600</b>
600	1175	970	578	610,0	10,0	100	399	5,8	676	605,0	<b>286-25-100-0600</b>
600	1465	970	868	610,0	10,0	150	180	2,6	450	667,0	<b>286-25-150-0600</b>
600	1755	970	1158	610,0	10,0	200	102	1,5	338	728,0	<b>286-25-200-0600</b>
700	1035	1090	468	711,0	10,0	50	1480	7,3	1134	814,0	<b>286-25-050-0700</b>
700	1285	1090	683	711,0	10,0	100	598	5,7	768	868,0	<b>286-25-100-0700</b>
700	1625	1090	1023	711,0	10,0	150	270	2,6	513	957,0	<b>286-25-150-0700</b>
700	1965	1090	1363	711,0	10,0	201	153	1,5	385	1047,0	<b>286-25-201-0700</b>

\*l = Mittenabstand / center distance

Kleinere Nennweiten siehe Typ 220. / For smaller nominal sizes see type 220.

Weitere Abmessungen und Werkstoffe auf Anfrage. /

Other dimensions and materials on request.

## Typ 286 Abmessungen

## Type 286 Specifications

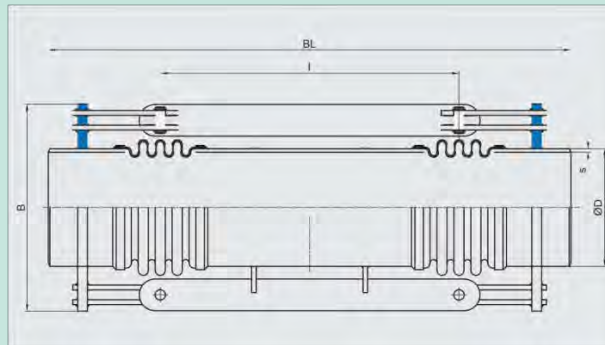

Druckstufe 40 barg (PN 40)  
Design pressure 40 barg (PN 40)

DN	Länge Length	Größte Breite Biggest width	Balg Bellow	Anschweißenden Weld ends		Bewegungsaufnahme Movement lateral	Verstellmomentrate Friction rate			Gewicht Weight	Artikel Article
	BL mm			B mm	I mm		ØD mm	s mm	2ΔN mm		
300	930	605	425	323,9	8,0	50	546	1,5	158	282,0	286-40-050-0300
300	1360	605	855	323,9	8,0	100	137	0,4	79	332,0	286-40-100-0300
300	1780	605	1275	323,9	8,0	150	62	0,2	53	381,0	286-40-150-0300
300	2200	605	1695	323,9	8,0	200	35	0,1	40	430,0	286-40-200-0300
350	895	620	398	355,6	8,0	60	314	2,3	204	245,0	286-40-060-0350
350	1165	620	668	355,6	8,0	100	113	0,8	122	277,0	286-40-100-0350
350	1495	620	998	355,6	8,0	150	51	0,4	82	316,0	286-40-150-0350
350	1825	620	1328	355,6	8,0	200	29	0,2	61	355,0	286-40-200-0350
400	940	700	420	406,4	10,0	69	383	3,3	254	320,0	286-40-069-0400
400	1130	700	610	406,4	10,0	100	184	1,6	175	348,0	286-40-100-0400
400	1440	700	920	406,4	10,0	151	82	0,7	116	396,0	286-40-151-0400
400	1740	700	1220	406,4	10,0	201	47	0,4	88	441,0	286-40-201-0400
450	975	785	457	457,0	10,0	50	692	2,9	475	475,0	286-40-050-0450
450	1435	785	917	457,0	10,0	101	174	0,8	237	565,0	286-40-101-0450
450	1885	785	1367	457,0	10,0	150	79	0,4	159	653,0	286-40-150-0450
450	2335	785	1817	457,0	10,0	200	45	0,2	120	741,0	286-40-200-0450
500	990	850	450	508,0	10,0	50	922	3,8	607	534,0	286-40-050-0500
500	1440	850	900	508,0	10,0	100	233	1,0	304	627,0	286-40-100-0500
500	1890	850	1350	508,0	10,0	150	104	0,5	203	721,0	286-40-150-0500
500	2340	850	1800	508,0	10,0	200	59	0,3	152	814,0	286-40-200-0500

\*I = Mittenabstand / center distance

Kleinere Nennweiten siehe Typ 220. / For smaller nominal sizes see type 220.

Weitere Abmessungen und Werkstoffe auf Anfrage. /

Other dimensions and materials on request.

## Druckstufe 63 barg (PN 63)

## Design pressure 63 barg (PN 63)

DN	Länge Length	Größte Breite Biggest width	Balg Bellow	Anschweißenden Weld ends		Bewegungsaufnahme Movement lateral	Verstellmomentrate Friction rate			Gewicht Weight	Artikel Article
	BL mm			B mm	I* mm		ØD mm	s mm	2ΔN mm		
250	855	530	393	273,0	10,0	50	338	1,2	123	222,0	286-63-050-0250
250	1245	530	783	273,0	10,0	100	86	0,3	62	267,0	286-63-100-0250
250	1635	530	1173	273,0	10,0	150	39	0,2	41	311,0	286-63-150-0250
250	2025	530	1563	273,0	10,0	201	22	0,1	31	356,0	286-63-201-0250
300	980	605	455	323,9	11,0	50	477	1,3	148	313,0	286-63-050-0300
300	1420	605	895	323,9	11,0	99	125	0,4	75	374,0	286-63-099-0300
300	1870	605	1345	323,9	11,0	150	56	0,2	50	436,0	286-63-150-0300
300	2320	605	1795	323,9	11,0	200	31	0,1	38	499,0	286-63-200-0300
350	955	640	407	355,6	12,5	52	575	2,4	317	376,0	286-63-052-0350
350	1325	640	777	355,6	12,5	100	161	0,7	166	435,0	286-63-100-0350
350	1715	640	1167	355,6	12,5	150	72	0,3	111	497,0	286-63-150-0350
350	2105	640	1557	355,6	12,5	200	41	0,2	83	560,0	286-63-200-0350

400	1015	735	458	406,4	14,2	49	981	2,5	373	510,0	286-63-049-0400
400	1475	735	918	406,4	14,2	100	248	0,7	186	612,0	286-63-100-0400
400	1935	735	1378	406,4	14,2	150	110	0,3	124	714,0	286-63-150-0400
400	2395	735	1838	406,4	14,2	200	62	0,2	93	816,0	286-63-200-0400

\*I = Mittenabstand / center distance

Kleinere Nennweiten siehe Typ 220. / For smaller nominal sizes see type 220.

Weitere Abmessungen und Werkstoffe auf Anfrage. /

Other dimensions and materials on request.

## Axialkompensator mit Pressfitting-Anschlussstücken Typ 290

## Axial expansion joint with pressfitting tube

### Type 290

Der Axialkompensator ist mit Pressfitting-Anschlussstücken ausgestattet.  
Er wird zur Aufnahme von Längenänderungen in

Keller- und Steigeleitungen sowie Etagenanschlussleitungen in der Heizungs-  
und Sanitärtechnik verwendet.

#### Beschreibung

Der Typ 290 ist in den Größen 18 mm bis 54 mm lieferbar. Er wird mit der  
gängigen "M-Kontour" geliefert und kann mit allen entsprechenden Werkzeugen  
verpresst werden.

Die Press-Verbindungstechnik verkürzt die Montagezeit erheblich, da das  
Rohrleitungssystem schnell, effizient und ohne Flamme zu installieren ist. Es  
bietet höchste Sicherheit bei gleichzeitiger Kostenersparnis.

Der Kompensator ist nicht für Schwingungen geeignet.



This axial expansion joint uses press fittings. It serves to compensate for  
length variations in cellar and riser pipes as well connecting pipes in  
heating and plumbing.

#### Description

Type 290 is available in the sizes 18 mm to 54 mm. It is supplied with the  
standard "M-contour" and can be press-fitted with all appropriate tools.

**Typ 290 Abmessungen  
Ausführung 1**

**Type 290 Specifications  
Model 1**

**Druckstufe 16 barg (PN 16)**  
Design pressure 16 barg (PN 16)

Using press fittings considerably reduces installation times as pipe systems can be installed quickly, efficiently and without brazing. This system offers the highest safety and also saves costs.

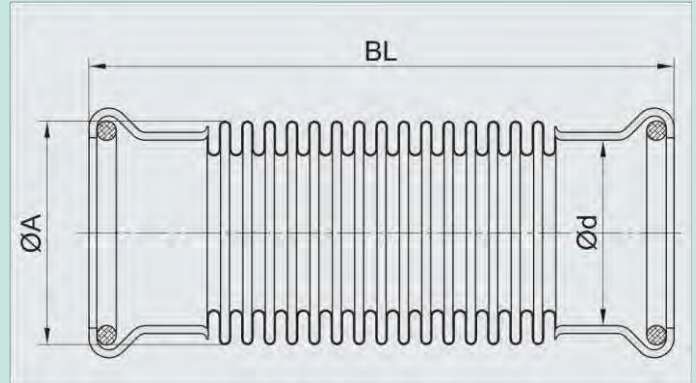

This expansion joint is not suitable for vibrations.

DN	Länge Length		Rohrdurchmesser Tube diameter		Balg Below	Bewegungsaufnahme Movement		Artikel rot Article red	Artikel blau Article blue
	BL mm	Ød mm	ØA mm	axial	2δN mm				
15	147	18	36	9		2090411800	20904118VA		
20	106	22	36	9		2090412200	20904122VA		
25	120	28	42	10		2090412800	20904128VA		
32	139	35	50	10		2090413500	20904135VA		

40	149	42	60	10	2090414200	20904142VA
50	176	54	75	14	2090415400	20904154VA

Weitere Abmessungen und Werkstoffe auf Anfrage. /  
Other dimensions and materials on request.

<b>Einsatzbeispiele</b>	Für Haustechnik, Industrie und Schiffbau
<b>Aufbau</b>	Einlagiger Wellenrohrbalg aus 1.4541 mit Pressmuffen aus C-Stahl (rot) oder Edelstahl (blau), Dichtring aus EPDM.
<b>Zulässige Betriebsdaten</b>	16 barg / 110 °C

<b>Application examples</b>	Building technology, industrie plants, shipbuilding
<b>Design</b>	Single layer corrugated tube bellows of 1.4541 with pressfitting tube of carbon steel (red) or stainless steel (blue). Sealing ring of EPDM
<b>Permissible operating data</b>	16 barg / 110 °C

## Werkstoffprüfung

Zur Einhaltung gleichbleibender Qualität werden auf Wunsch folgende Prüfungen am Produkt durchgeführt und in den Dokumentationen festgehalten:

### Zerstörungsfreie Prüfungen (ZFP)

- Sichtprüfung
- Dichtheitsprüfung
- Farbeindringprüfung
- Röntgenprüfung
- Hydrostatische Prüfung
- Magnetpartikelprüfung
- Ultraschallprüfung
- Verwechslungsprüfung (PMI)
- Heliumdichtigkeitsprüfung
- Wirbelstromprüfung
- Maßprüfung

### Zerstörende Prüfungen (ZP)

- Grenzlastspielzahlprüfung
- Instabilitätsprüfung
- Bewegungsprüfung
- Schwingungsprüfung
- Bersttest
- Metallurgische Tests
- Tiefungsversuch durch Erichsen
- Härteprüfung

## Material testing



Werden in der Regel nicht durchgeführt.

To maintain a consistent quality, the following tests can be carried out on the product and documented on request:

Die in diesem Katalog aufgeführten Kompensatoren können standardmäßig mit folgender Dokumentation geliefert werden:

▫ für Kompensatoren mit Einstufung gemäß DGRL 2014/68/EU



**Non-destructive tests (NDT)**

- Visual test
- Leak tightness test
- Dye penetrant test
- Radiographic examination
- Hydrostatic pressure testing
- Metallurgische Tests
- Magnetic particle examination
- Ultrasonic testing
- Positive material identification (PMI)
- Helium leak testing | Eddy current test
- Dimensional check

- Werkstoff-Abnahmeprüfzeugnis 3.1/EN 10204
- Prüfbescheinigung
- Konformitätsbescheinigung gem. DGRL 2014/68/EU
- HPT-Drucktest
- CE-Kennzeichnung gem. DGRL 2014/68/EU
- NDT gem. DGRL 2014/68/EU
- für Kompensatoren gem. EJMA
- Werkstoff-Abnahmeprüfzeugnis 3.1/EN 10204
- Alternativ: Abnahmeprüfzeugnis 2.1/EN 10204
- Optional HPT-Drucktest
- eine Zertifizierung ist nach EN und/oder ASME möglich

**Destructive tests (DT)**

- Fatigue life testing
- Squirm testing
- Movement test
- Vibration test
- Burst test
- Metallurgy inspections
- Cupping test (Erichsen test)
- Hardness test Usually not

carried out.

**Dokumentation (Standard)**

**Sonstige Dokumentation**

- Prüfbescheinigung
- Werkstoffzertifikat gem. EN 10204/3.1
- Konformitätserklärung
- Konformitätsbescheinigung
- Berichte VT, PT, TP, RT, UT, MPI, PMI
- Bescheinigung NDT-Prüfer (EN 473/ISO 9712)
- Prüfberichte Druck- und Dichtheitsprüfung und Verfahren
- Kalibrierzertifikat für Druckmessgeräte
- Prüf- und Testplan (ITP)
- Messbericht
- Bericht Farbanstrich einschl. Datenblätter
- ISO-Zertifikate (EN ISO 9001, EN ISO 3834-2)
- Zertifikat der Typenzulassungen

- Reinigungszertifikat und Verfahren
- Lieferantenzertifikat EN ISO 9001
- Montageanleitung

#### Dokumente externer Zertifizierungsstellen

- Beiwohnen der Druckprüfung
- Genehmigung der Berechnungen
- Bauartzulassung
- Endabnahme
- Typenzulassung
- Zerstörende Werkstoffprüfung

#### Weiterführende zugehörige Dokumentation (auf Wunsch)

- Gemäß Spezifikationen der Kernenergiebranche
- Gemäß NORSOK-Spezifikationen
- Gemäß Spezifikationen der Öl-/Gasbranche
- Gemäß speziellen Spezifikationen/Anforderungen des Kunden
- Schweißdokumentation

## Dokumentation

### Documentation (Standard)

The expansion joints shown in this catalogue can be supplied with the following documentation as standard:

- for expansion joints with classification according to PED 2014/68/EU
  - Material inspection certificate 3.1/EN 10204
  - Inspection certificate
  - Declaration of conformity according to PED 2014/68/EU
  - HPT pressure test
  - CE mark according to PED 2014/68/EU
  - NDT according to PED 2014/68/EU
- for expansion joints according to EJMA
  - Material inspection certificate 3.1/EN 10204
  - Alternative: Inspection certificate 2.1/EN 10204
  - Optional HPT pressure test
- Certification according to EN and/or ASME is available

### Other documentation

- Inspection certificate
- Material certificates according to EN 10204/3.1
- DoC - Declaration of Conformity

WILLBRANDT Kompensatoren können gem. folgenden Konstruktionsnormen ausgelegt werden:

## Lebensdauer

- EN 14917
- EN 13445
- EN 13480
- AD2000
- ASME B31.1
- ASME B31.3

- CoC - Certificate of Conformity
- VT, PT, TP, RT, UT, MPI, PMI reports
- NDT operator certificate (EN 473/ISO 9712)
- Pressure and tightness test report and procedure
- Pressure gauge calibration certificate
- ITP - Inspection and Test Plan
- Measuring report
- Paint report incl. datasheets
- ISO certificates (EN ISO 9001, EN ISO 3834-2)
- Type approval certificate
- Cleaning certificate and procedure
- Supplier EN ISO 9001 certificate
- Installation instruction

### 3rd party documents

- Witness pressure test
- Calculation approval
- Design approval
- Final inspection

- According to testing
- According to type approval

## Documentation

### Other related documents

- According to nuclear specifications
- According to NORSOK specifications
- According to oil/energy specifications
- According to special customer specifications/requirements
- Welding documentation

## Maß- und Endkontrolle

Vor Auslieferung des Kompensators findet eine Endkontrolle statt, die mind. die Kontrolle der Hauptabmessungen, der Ident-Nr. sowie die Ausführung der Verpackung beinhaltet. Alle Kompensatoren, die unter die Druckgeräterichtlinie (2014/68/EU) fallen, sind CE-gekennzeichnet.

## Dimensionl and final check

Prior to delivery, the expansion joint undergoes a final inspection, which includes at least a check of the main dimensions, identification number and type of packaging. All expansion joints that come under the Pressure Equipment Directive (2014/68/EU) carry a CE mark.

- ASME VIII Div. I
- EJMA

## Service life

- CAD-Zeichnungen
- 3D-Zeichnungen

Standardmäßig sind unsere Bälge für eine Lebensdauer von 1000 Lastwechseln ausgelegt. Ein Lastwechsel bzw. ein Zyklus entspricht der Gesamtbewegung eines Balges von Maximum bis Minimum, bei

bestimmtem Auslegungsdruck und Auslegungstemperatur. Somit lässt sich durch Unterschreiten der Auslegungsdaten und der max. Bewegung die Lastwechselzahl erhöhen (siehe folgende Tabelle).

WILLBRANDT expansion joints can be designed according to the following design standards:

- EN 14917
- EN 13445
- EN 13480
- AD2000
- ASME B31.1
- ASME B31.3
- ASME VIII Div. I
- EJMA
- CAD-Zeichnungen
- 3D-Zeichnungen

Our bellows are designed for a service life of 1,000 load cycles as standard. One load cycle or one cycle corresponds to the total movement of bellows from the maximum to the minimum, at a specific design pressure and design temperature. In this way, the cycles-to-failure is increased if the design data and maximum movement tolerances remain below specific values (see following chart).

Unsere ausgewählten Werkstoffkombinationen für Standardkompensatoren sind für die meisten Anwendungen geeignet. Die Auswahl der Balgwerkstoffe erfolgt in der Regel anhand folgender Aspekte:

- Verformbarkeit (Duktilität)
- Eignung zum Schweißen
- Thermische Stabilität
- Stärke
- Korrosionsbeständigkeit
- Korrosionsfaktoren, wie Prozessmedien, Umgebung, interne Reinigungsmittel
- Mechanische Eigenschaften: Anwendungen mit hohen oder tiefen Temperaturen, Betriebsspannungen
- Herstellungseigenschaften: (Kalt-) Formbarkeit, Kosten und Werkstoffverfügbarkeit.

Insbesondere bei aggressiven Bedingungen sind spezielle Werkstoffe mit hoher Korrosionsbeständigkeit zu verwenden. Die Korrosionsbeständigkeit muss mindestens der des anschließenden Rohres entsprechen. Aufgrund des Bedarfs an hoch flexiblen Kompensatoren kommen insbesondere mehrlagige Bälge zum Einsatz, bei denen besonders dünnwandige Wellen Korrosion verhindern. Im Zweifelsfall empfiehlt sich in Bezug auf die Bälge - zumindest für die

### Lebensdauerdiagramm / Chart of service life

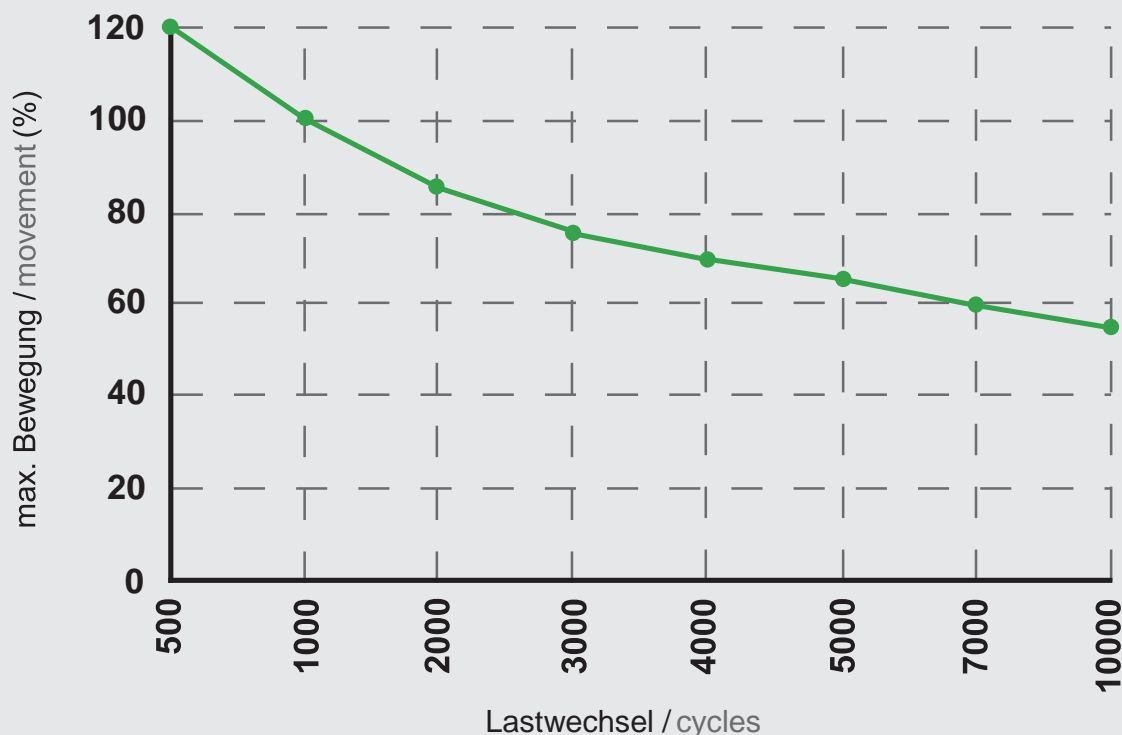

### Balgwerkstoffe

### Bellow materials

innere Lage - die Verwendung eines Werkstoffes mit höherer

Korrosionsbeständigkeit. In vielen Fällen sind Legierungen auf Nickelbasis wie Inconel 600, Inconel 625, Incoloy 825 geeignet.

Die in diesem Katalog bereitgestellten Beständigkeitstabellen können bei der Werkstoffwahl hilfreich sein. Jedoch sollte die Auswahl des geeigneten korrosionsbeständigen Werkstoffes auf Grundlage der

## Druckeinheiten

Erfahrung des Anwenders erfolgen, der mit den speziellen Eigenschaften seiner Anlage und des Betriebsmediums am besten vertraut ist.

### Balgwerkstoffe

Für Druckanwendungen gemäß EN 14917 kann der Temperaturbereich der vorherigen Seite entnommen werden. Für Niederdruckanwendungen und/oder andere Konstruktionsnormen gelten höhere/andere Temperaturbereiche.

Our selected material combinations for standard expansion joints are suitable for the majority of applications. The selection of the bellow material is generally based on the following aspects:

- Formability (Ductility)
- Weld ability
- Thermal stability
- Strength
- Corrosion resistance
- Corrosion properties such as process media, surrounding environment, internal cleaning agents
- Mechanical properties: high temperature service, cryogenic service, operating stresses
- Manufacturing properties: forming and cold working capabilities, cost and material availability.

In particularly aggressive conditions, special materials with high corrosion resistance should be used. The corrosion resistance should be at least equal to that of the adjoining pipe. The demand for highly flexible expansion joints focuses on the use of multi-ply bellows, where very thin-walled convolutions prevent corrosion. Whenever in doubt, it is recommended to choose a material with a higher corrosion resistance for the bellows, at least for the inner ply. In many cases, nickel-based alloys like Inconel 600, Inconel 625, Incoloy 825 are suitable.

The resistance tables provided in this catalogue can be helpful in material selection. However, the choice of a suitable corrosion resistant material should be based on the experience of the user, who is most familiar with the particular features of the system and the operating medium.

### Bellow materials

For pressurised applications according to EN 14917, the temperature range can be seen from the previous page. For lower pressure applications and/or other design codes, higher/other temperature ranges apply.

## Pressure Units

### Absolut und Atmosphär-Relativ

Im Alltagsgebrauch wird der Druck oft mit Bezug auf den atmosphärischen Druck gemessen. D. h. wenn jemand sagt, seine Autoreifen haben einen Druck von 2,3 bar, dann haben sie tatsächlich 3,3 bar, jedoch 2,3 bar über dem atmosphärischen Druck (von ca. 1 bar). Also 2,3 bar Atmosphär-Relativ ist gleich 3,3 bar absolut.

Bei absoluten Druckangaben wird die Einheit "bara" oder "bar(a)" für "bar absolut" verwendet.

Relative Druckangaben erhalten die Einheit bar/ü (bar über atmosphärischen Druck) oder barg (bar gauge [Manometer]).

### Absolute and relative atmospheric pressure

In everyday use, pressure is often measured with reference to

Einheitenzeichen	Name der Einheit	Pa=N/m <sup>2</sup>	bar	m WS	Torr = mm Hg	lbf/in <sup>2</sup>	in Hg	Unit symbol	Unit name
1 Pa = 1 N/m <sup>2</sup>	Pascal / Pascal	1			0,00001	0,0001	0,0075	0,00014	0,000295
1 bar	Bar / bar	100000			1	10,1972	750,062	14,5037	29,53
1 kp/m <sup>2</sup> =1mm WS millimetre water column	Millimeter Wassersäule	9,80665			-	0,001	0,07356	0,00142	0,002918
1 m WS 1 m WC metre water column	Meter Wassersäule metre water column	9806,65			0,09807	1	73,5559	1,42233	2,8959
1 kp/cm <sup>2</sup> =1 at	Technische Atmosphäre technical atmosphere	98066,5			0,98067	10	735,559	14,2233	28,959
1 atm	Physikalische Atmosphäre physical atmosphere	101325			1,01325	10,3323	760	14,696	29,9213
1 Torr = 1 mm Hg	Millimeter Quecksilbersäule millimetre of mercury	133,322			0,00133	0,013595	1	0,01934	0,03937
1 lbf/in <sup>2</sup>	pound-force per square inch pound-force per square inch	6894,76			0,06895	0,70307	51,7149	1	2,03602
1 lbf/ft <sup>2</sup>	pound-force per square foot pound-force per square foot	47,8803			0,00048	0,00488	0,35913	0,00694	0,01414
1 in Hg	inch Quecksilbersäule inch of mercury	3386,39	0,03386	0,34532	25,4	0,49115	1		

atmospheric pressure, i.e. when someone says their car tyres have a pressure of 2.3 bar, they are actually 3.3 bar, but 2.3 bar above atmospheric pressure (approx. 1 bar). So 2.3 bar relative atmosphere is the same as 3.3 bar absolute atmosphere.

The unit "bara" or "bar(a)" is used for absolute pressure.

Relative pressures is given in the unit "barg" (bar gauge [manometer]).

## Typ 286 Abmessungen

### Type 286 Specifications

**Lieferbares Zubehör** Available accessories

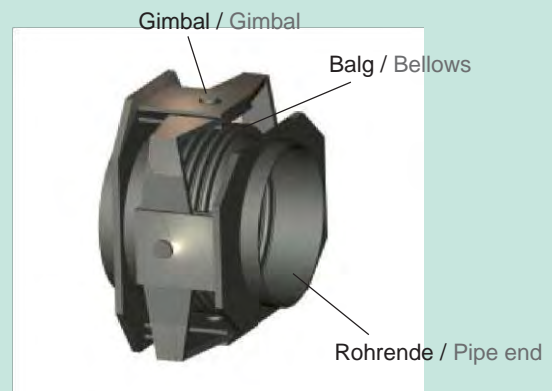
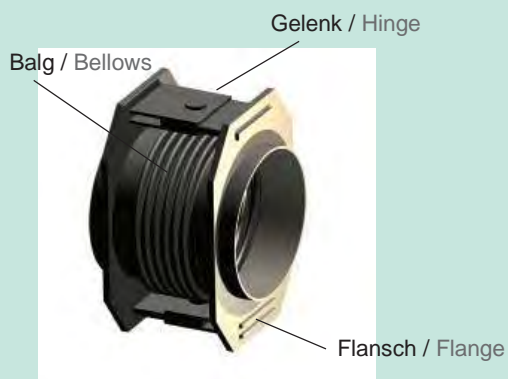
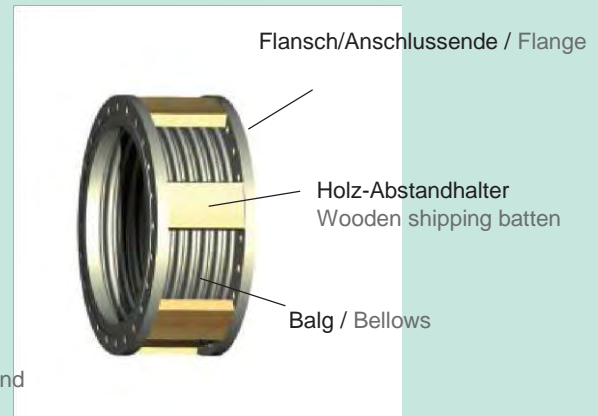
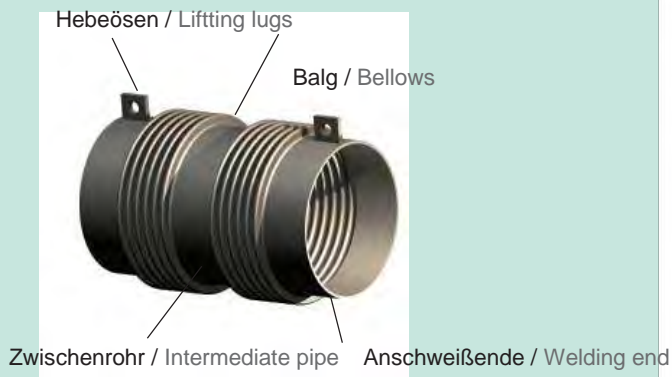

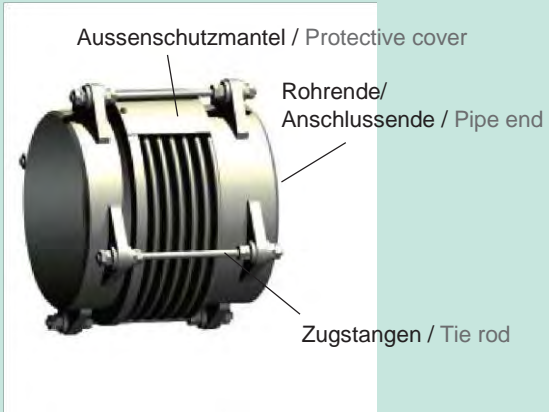

Transportsicherung/Gelb/schwarz-

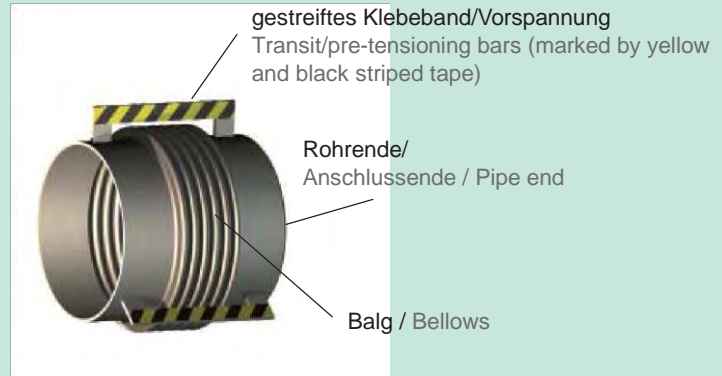

## Beständigkeitstabelle

### Korrosionsverhalten

Die Beständigkeitstabellen erläutern das Korrosionsverhalten der verschiedenen Metalle, die häufig für Bälge und Kompensatoren verwendet werden.

<b>0</b>	<b>Geeignet</b>
	Beständig.
<b>1</b>	<b>Eingeschränkte Eignung</b>
	Gleichmäßige Korrosion mit Verringerung der Stärke von bis zu 1 mm/Jahr.
	P = Risiko Lochkorrosion S = Risiko Spannungskorrosion / Rissbildung
<b>2</b>	<b>Nicht empfohlen</b>
	Kaum beständig .Gleichmäßige Korrosion mit Verringerung der Stärke von mehr als 1 mm/Jahr bis zu 10 mm/Jahr.
<b>3</b>	<b>Ungeeignet</b>
	Nicht beständig. Verschiedene Formen von Korrosion.

## Resistance tables

### Corrosion behaviour

The resistance tables indicate the corrosive behaviour of metals often used for bellows and expansion joints.

<b>0</b>	<b>Suitable</b>
	Resistant
<b>1</b>	<b>Restricted</b>
	Uniform corrosion up to 1 mm/year.
	P = Risk o S = Risk o
<b>2</b>	<b>Not recom</b>
	Hardly resistant. reduction thickness up to 10 mm
<b>3</b>	<b>Unsuitabl</b>
	Not resis

### Abkürzungen in den Tabellen

<b>dr</b>	trocken
<b>mo</b>	feucht
<b>hy</b>	wässrige Lösung
<b>me</b>	geschmolzen
<b>cs</b>	kalt gesättigt (bei Raumtemperatur)
<b>sa</b>	gesättigt (am Siedepunkt)
<b>bp</b>	Siedepunkt
<b>adp</b>	Säuretaupunkt

### Table abbreviations

<b>dr</b>	dry condition
<b>mo</b>	moist cond
<b>hy</b>	hydrous so
<b>me</b>	melted
<b>cs</b>	cold-satura
<b>sa</b>	saturated
<b>bp</b>	boiling point
<b>adp</b>	acid dew

Medium / Medium  
Bezeichnung / Designation

Edelstahl / Stainless steel

Werkstoffe / M  
Nickellegierung





Beständigkeitstabelle

Resistance tables

Chemische Formel / Chemical Formula	Aggregatzustand Aggregate state	Konzentration Concentration	Temperatur Temperature	unlegierte/ niedriglegierte Stähle Non/low-alloy steels	Ferritischen Stähle Ferritic steels	Austenitischen Stähle Austenitic steels	Austenitischen + Mo-Stähle Austenitic + Mo steels	/ Alloy	Alloy 600 2.4816	/ Alloy	2.4610, 2.4619 C-4, C-246	/ Alloy	Nickel Nickel	Titan Titanium	Tantal Tantalum	Aluminium Aluminium
		%	°C													
<b>Acetanilide (Antifebrin)</b> C <sub>8</sub> H <sub>9</sub> NO			<114	0	0	0	0	0	0	0	0	0	0	0	0	0
<b>Acetic Acid</b> CH <sub>3</sub> COOH or C <sub>2</sub> H <sub>4</sub> O <sub>2</sub>		5	20	3	0	0	0	0	1	0	0	1	3	0	0	0
		5	bp	3	3	0	0	0	1	0	0	1	0	0	0	0
		50	20	3	3	0	0	0	1	0	0	1	3	1	0	0
		50	bp	3	3	3	0	0	1	0	0	1	3	0	0	3
		80	20	3	3	P	P	0	1	0	0	1	3	0	0	0
		96	20	3	3	3	P	0	1	0	0	1	3	0	0	0
		98	bp	3	3	3	3	0	1	0	0	1	0	0	0	0
<b>Acetic acid vapour</b>		33	20		3	1	1									
		100	>50		3	3	3	0	1		0	1	3	0		1
		100	<bp		3	3	3	0	3		0	3	3	0		3
<b>Acetic aldehyde</b> CH <sub>3</sub> -CHO		100	bp	1	1	0	0	0	0	0	0	0	0	0	0	0
<b>Acetic anhydride</b> (CH <sub>3</sub> -CO) <sub>2</sub> O		all	20	1	0	0	0	0	1	0	0	1	1	0	0	0
		100	60	3		0	0				0		1	0	0	1
		100	bp	3		0	0		3		0		1	0	0	3
<b>Acetic anilide (antifefarine)</b>			<114	0	0	0	0	0	0	0	0	0	0	0	0	0
<b>Acetone</b> CH <sub>3</sub> COCH <sub>3</sub>		100	bp	1	0	0	0	0	0	0	0	0	0	0	0	0
<b>Acetyl chloride</b> CH <sub>2</sub> COCl			20	1	1	1	1	1	1	0	0	1	1		0	1
<b>Acetylene</b> C <sub>2</sub> H <sub>2</sub>	dr		20	0	0	0	0	0	0	0	0	0	0	0	0	0
	dr		200	1	0	0	0	0	0	0	0	0	3	0	0	1
<b>Acetylen dichloride</b> C <sub>2</sub> H <sub>2</sub> Cl <sub>2</sub>	hy	5	20													1
	dr	100	20	0	P	P	P	0	0	0		0	0		0	0
<b>Acetylen tetrachloride</b> CHCl <sub>2</sub> -CHCl <sub>2</sub>	dr	100	20	0	0	0	0				0		0	0		0
	dr	100	bp	0	0	0	0				0		0	1		3
	mo		bp	1									1			3
<b>Adipic acid</b> HOOC(CH <sub>2</sub> ) <sub>4</sub> COOH		all	200	0	0	0	0	0	0	0	0	0	0	0	0	0
<b>Alcohol</b> see ethyl or methyl alcohol													0			
<b>Allyl alcohol</b> CH <sub>2</sub> CHCH <sub>2</sub> OH		100	bp			0	0	0	0	0	1	0	0			
<b>Allyl chloride</b> CH <sub>2</sub> =CHCH <sub>2</sub> Cl		100	25				0	0	0	0		0	0			
<b>Alum</b> KAl (SO <sub>4</sub> ) <sub>2</sub>		100	20	1	1	0	0	0	1	0	0				0	1
	hy	10	20	1	0	0	0				1		0	0		1
	hy	10	<80	1	1	0	0				1		0	0		
	sa				3	3	1				3					

**Beständigkeitstabelle**

**Resistance tables**

<b>Aluminium</b> Al	me		750	3	3	3	3		
<b>Aluminium acetate</b> (CH <sub>3</sub> -COO) <sub>2</sub> Al(OH)	hy	3	20	3	0	0	0		
<b>Aluminium chloride</b> AlCl <sub>3</sub>	hy	5	20	3	3	3	P	1	1
<b>Aluminium fluoride</b> AlF <sub>3</sub>	hy	10	25	3	3	3	3		
<b>Aluminium formate</b> Al(HCOO) <sub>3</sub>				1	0	0	0	0	0
<b>Aluminium hydroxide</b> Al(OH) <sub>3</sub>	hy	10	20	1	3	0	0	0	
<b>Aluminium nitrate</b> Al(NO <sub>3</sub> ) <sub>3</sub>				0	0	0	0	0	0
<b>Aluminium oxide</b> Al <sub>2</sub> O <sub>3</sub>			20	1	1	0	0	0	

Medium / Medium				Edelstahl / Stainless steel				Werkstoffe / M	
Bezeichnung / Designation	Aggregatzustand / Aggregate state	Konzentration / Concentration	Temperatur / Temperature	unlegierte / niedriglegierte Stähle / Non/low-alloy steels	Ferritischen Stähle / Ferritic steels	Austenitischen Stähle / Austenitic steels	Austenitischen + Mo-Stähle / Austenitic + Mo steels	/ Alloy	2.4816 Alloy 600 / Alloy
Chemische Formel / Chemical Formula		%	°C						
<b>Aluminium potassium sulphate</b> see alum									
<b>Aluminium sulphate</b> Al <sub>2</sub> (SO <sub>4</sub> ) <sub>3</sub>	hy	10	3	<bp	3	3	0	0	1
	hy	15	3	50	3	3	1		1
<b>Ammonia</b> NH <sub>3</sub>	dr	10	20	0	0	0	0		0
	hy	2	20	0	0	0	0		0
	hy	20	40	0	0	0	0	0	1
	hy	sa	bp	0	0	0	0	0	3
<b>Ammonia bromide</b> NH <sub>4</sub> Br	hy	10	25	3	P	P	P	0	
<b>Ammonium acetate</b> CH <sub>3</sub> -COONH <sub>4</sub>				1	0	0	0		
<b>Ammonium alum</b> NH <sub>4</sub> Al(SO <sub>4</sub> ) <sub>2</sub>	hy	cs	20			0	0		
<b>Ammonium bicarbonate</b> (NH <sub>4</sub> )HCO <sub>3</sub>	hy			0	0	0	0	1	3
<b>Ammonium bifuoride</b> NH <sub>4</sub> HF <sub>2</sub>	hy	10	25	3	3	3	3		
	hy	100	50	3	3	0	0		
<b>Ammonium bromide see ammonia bromide</b>									
<b>Ammonium carbonate</b> (NH <sub>4</sub> ) <sub>2</sub> CO <sub>3</sub>	hy	1	20	0	0	0	0	0	0
		50	bp	0	0	0	0	0	0
<b>Ammonium chloride</b> NH <sub>4</sub> Cl	hy	1	20	1	P	P	P	0	0
	hy	10	100	1	P	P	P	0	0
	hy	50	bp	1	P	P	P	0	1

aterials  
n /



Beständigkeitstabelle

Resistance tables

<b>Ammonium fluoride</b>		10	25	1	1	0	0				0			1	0
NH <sub>4</sub> F	hy	sa	70	3											
	hy	20	80	3		3	3				0			0	
<b>Ammonium fluosilicate</b> (NH <sub>4</sub> ) <sub>2</sub> SIF <sub>6</sub>	hy	20	40	3		1	0	0	0	0	0	0	0		
<b>Ammonium formate</b> HCOONH <sub>4</sub>	hy	10	20	1	0	0	0	0	0	0	0	0	0	0	0
		10	70											0	0
<b>Ammonium hydroxide</b> NH <sub>4</sub> OH		100	20		0	0	0	0	0	0	0	3	0	0	0
											0				1
<b>Ammonium nitrate</b> NH <sub>4</sub> NO <sub>3</sub>	hy	5	20	3	0	0	0	0	1	0	0	3		0	0
	hy	100	bp	3	0	0	0	0			0	3		0	0
<b>Ammonium oxalate</b> (COONH <sub>4</sub> ) <sub>2</sub>	hy	10	20	1	1	0	0		1	0	0	1		0	0
	hy	10	bp	3	3	1	0		1	0		1		1	0
<b>Ammonium perchlorat</b> NH <sub>4</sub> ClO <sub>4</sub>	hy	10	20		P	P	P				1			0	
<b>Ammonium persulphate</b> (NH <sub>4</sub> ) <sub>2</sub> S <sub>2</sub> O <sub>8</sub>	hy	5	20		0	0	0	0	1	0	0	3	3	0	0
	hy	10	25	3	1	1	1				0	3	3	0	3
<b>Ammonium phosphate</b> NH <sub>4</sub> H <sub>2</sub> PO <sub>4</sub>	hy	5	25	0	1	1	0	0	1	0	0	1	1	0	0
<b>Ammonium rhodanide</b> NH <sub>4</sub> CNS		70		0	0	0								0	0
<b>Ammonium sulphate</b> (NH <sub>4</sub> ) <sub>2</sub> SO <sub>4</sub>	hy	1	20	0	0	0	0	0	1	0	0	1	1	0	0
	hy	10	20	0	1	1	0	0	3		1	1	1	3	0
	hy	sa	bp	1		0					3	2		0	0
<b>Ammonium sulphite</b> (NH <sub>4</sub> ) <sub>2</sub> SO <sub>3</sub>		cs	20		1	0	0	3	3			3	3	0	0
		sa	bp		3	1	1	3	3			3	3	0	0
<b>Ammonium sulphocyanate</b> see ammonium rhodanide															
<b>Amyl acetate</b> CH <sub>3</sub> -COOC <sub>5</sub> H <sub>11</sub>		all	20					1	1	1	1	1	1		1
		100	bp	1		1	1		0	1	1	0	0		0
<b>Amyl alcohol</b> C <sub>5</sub> H <sub>11</sub> OH		100	20	0	0	0	0		0	0	0	0	0	0	
		100	bp	1	0	0	0							0	1

Medium / Medium

Werkstoffe / Materials

Bezeichnung / Designation	Medium / Medium			Edelstahl / Stainless steel				Nickellegierungen / Nickel alloys				Reinmetalle / Pure metals				
	Aggregatzustand / Aggregate state	Konzentration / Concentration	Temperatur / Temperature	unlegierte/ niedriglegierte Stähle / Non/low-alloy steels	Ferritischen Stähle / Ferritic steels	Austenitischen Stähle / Austenitic steels	Austenitischen + Mo-Stähle / Austenitic + Mo steels	/ Alloy	Alloy 600	2.4816	/ Alloy	2.4610, 2.4619 C-4, C-246	/ Alloy	Nickel / Nickel	Titan / Titanium	Tantal / Tantalum
<b>Amyl chloride</b> CH <sub>3</sub> (CH <sub>2</sub> ) <sub>3</sub> CH <sub>2</sub> Cl		100	bp	1		P	P	0	1	0	0	1	1	0	0	3
<b>Amyl thiol</b>		100	160			0	0				0					



Beständigkeitstabelle

Resistance tables

<b>Aniline</b>		100	20			0	0	0	1
C <sub>6</sub> H <sub>5</sub> NH <sub>2</sub>		100	180			1	1	0	
<b>Anilin chloride</b>	hy	5	20		P	P	P		
C <sub>6</sub> H <sub>5</sub> NH <sub>2</sub> HCl	hy	5	100		P	P	P		
<b>Anilin hydrochloride see anilin chloride</b>									
<b>Anilin sulphate</b>			20				0		
<b>Anilin sulphite</b>	hy	10	20				0		1
	hy	cs	20				0		
<b>Antifreeze (Glysantine)</b>			20		0	0	0	0	0
<b>Antimony</b>	me	100	650	3					
Sb									
<b>Antimon trichloride</b>	dr		20	0	3	3	3		
SbCl <sub>3</sub>	hy		100	1	3	3	3		
<b>Aqua regia</b>			20	3	3	3	3		3
3 HCl+HNO <sub>3</sub>									
<b>Arsenic</b>			65			0	0		
As			110			1	1		
<b>Arsenic acid</b>	hy		20	3		0	0		
H <sub>3</sub> AsO <sub>4</sub>	hy	90	110		3	3	3		3
<b>Asphalt</b>			20	0	0	0	0		
<b>Azobenzene</b>			20	0	0	0	0	0	0
C <sub>6</sub> H <sub>5</sub> -N=N-C <sub>6</sub> H <sub>5</sub>									
<b>Baking powder</b>	mo			1	0	0	0	0	0
<b>Barium carbonate</b>			20	3	0	0	0	0	
BaCO <sub>3</sub>									
<b>Barium chloride</b>	hy	5	20		P	P	P	1	1
BaCl <sub>2</sub>	hy	25	bp		P	P	P	1	1
<b>Barium hydroxide</b>	solid	100	20	0	0	0	0	0	1
Ba(OH) <sub>2</sub>	hy	all	20	0	0	0	0	0	1
	hy	all	bp	0	0	0	0		
		100	815	0	0	0	0	0	1
	hy	cs	20	0	0	0	0		
	hy	sa	bp	0	0	0	0		
		50	100	0	0	0	0	0	1
<b>Barium nitrate</b>	hy	all	bp		0	0	0	0	1
Ba(NO <sub>3</sub> ) <sub>2</sub>									
<b>Barium sulphate</b>			25	0	0	0	0	0	
BaSO <sub>4</sub>									
<b>Barium sulphide</b>			25		0	0	0		
BaS									
<b>Basic aluminium acetat see aluminium acetat</b>									



Beständigkeitstabelle

Resistance tables

Beer		100	20	3	0	0	0	0	0	0	0	0	0	0	0	0
		100	bp	3	0	0	0	0	0	0	0	0	0	0	0	0
Benzaldehyde C <sub>6</sub> H <sub>5</sub> -CHO	dr		bp		0	0	0							1	0	0
Benzene		100	20		0	0	0	0	0	0	1	0	0	0	0	0
		100	bp		0	0	0		1	1	1	1	1	1	0	1
Benzenesulfonic acid C <sub>6</sub> H <sub>5</sub> -SO <sub>3</sub> H	hy	5	40	3	0	0	0									
	hy	5	60	3	3	1	1									
Benzine		100	25		0	0	0	0	0	0	0	0		0		1
Benzoic acid C <sub>6</sub> H <sub>5</sub> -COOH	hy	all	20	1	0	0	0	0	0	0	0	0	0	0	0	0
	hy	all	bp	3	0	0	0	0	0	0	0	0	0	0	0	3

Medium / Medium

Werkstoffe / Materials

Bezeichnung / Designation  Chemische Formel / Chemical Formula	Medium / Medium			Edelstahl / Stainless steel				Nickellegierungen / Nickel alloys					Reinmetalle / Pure metals			
	Aggregatzustand Aggregate state	Konzentration Concentration	Temperatur Temperature	unlegierte/ niedriglegierte Stähle Non/low-alloy steels	Ferritischen Stähle Ferritic steels	Austenitischen Stähle Austenitic steels	Austenitischen + Mo-Stähle Austenitic + Mo steels	/ Alloy	Alloy 600 2.4816	/ Alloy	2.4610, 2.4619 C-4, C-246	/ Alloy	Nickel Nickel	Titan Titanium	Tantal Tantalum	Aluminium Aluminium
Benzyl alcohol C <sub>6</sub> H <sub>5</sub> -CH <sub>2</sub> OH		all	20	1	1	0	0	0	0	0	0	0	0	0	0	0
Biphenyl C <sub>6</sub> H <sub>5</sub> -C <sub>6</sub> H <sub>5</sub>		100	20	0	0	S	S	0	0	0	0	0	0	0	0	0
		100	400	0	0	S	S	0	0	0	0	0	0	0	0	0
Blood			20	3	0	0	0	0	0	0	0	0	0	0		
Boiled oil			20	1	0	0	0	0	0	0	0	0	0	0		0
Borax Na <sub>2</sub> B <sub>4</sub> O <sub>7</sub>	hy	cs		1	0	0	0							0	0	0
	hy	sa		3	0	0	0							0	0	1
Boric acid H <sub>3</sub> BO <sub>3</sub>	hy	50	100	3	0	0	0	0	1	0	0	1	1	0	0	1
	hy	50	150	3	1	0	0	0	1	0	0	1	1	0	0	1
	hy	70	150	3	1	1	1	0	1	0	0	1	1	0	0	1
Boron B			20	0	0	0	0									
			900	0												
Bromine Br	dr	100	20	P	P	P	P	1	0	0	0	0	0	3		3
	mo	100	20	P	P	P	p		3		3	0	0	0		3
Bromine water		0,03	20		P	P	P									
		1	20		P	P	P									
Bromoform CHBr <sub>3</sub>	dr		20	0	0	0	0	0	0	0	0	0				3
	mo			3	0	0	0	0	0	0	0	0				3
1,3 - Butadiene CH <sub>2</sub> =CHCH=CH <sub>2</sub>								0	0	0		0	0			0
Butane C <sub>4</sub> H <sub>10</sub>		100	20	0	0	0	0	0	0	0	0	0	0			1
		100	120		1	0	0				1					
Butanol CH <sub>3</sub> -CH <sub>2</sub> -CH <sub>2</sub> -CH <sub>2</sub> OH		100	20	0	0	0	0	0	0	0	0	0	0	0	0	0
		100	bp	0	0	0	0	0	0	0	0	0	0	0	0	0



Beständigkeitstabelle

Resistance tables

Butter			20	3	0	0	0	0	0
Buttermilk			20	3	0	0	0	0	0
Butylacetate			20	1	0	0	0	0	0
CH <sub>3</sub> COOC <sub>4</sub> H <sub>9</sub>			bp	1	0	0	0	0	0
Butyric acid	hy	cs	20	3	0	0	0	1	3
CH <sub>3</sub> -CH <sub>2</sub> -CH <sub>2</sub> -COOH	hy	sa	bp	3	3	3	0	1	3
Cadmium Cd	me					3	3		
Calcium Ca			850	3		3	3		
Calcium bisulphite		cs	20	3	3	0	0		
CaSO <sub>3</sub>		sa	bp	3	3	3	0		
Calcium carbonate CaCO <sub>3</sub>			20	1	0	0	0	0	0
Calcium chlorate	hy	10	20		P	P	P	1	1
Ca(ClO <sub>3</sub> ) <sub>2</sub>	hy	10	100		3	3	P	1	1
Calcium chloride CaCl <sub>2</sub>	hy	5	100	3	P	P	P		
	hy	10	20	3	P	P	P	0	0
		cs		3	P	P	P	0	0
		sa		3	3	P	P	0	0
Calcium hydroxide Ca(OH) <sub>2</sub>				0	0	0	0	1	1
Calcium hypochlorite Ca(OCl) <sub>2</sub>	hy	2	20	3	3	3	P	0	3
	hy	cs		3	3	3	P		
Calcium nitrate Ca(NO <sub>3</sub> ) <sub>2</sub>			20	3	0	0	0	0	0
		all	100	3	0	0	0	0	0
Calcium oxalate (COO) <sub>2</sub> Ca	mo		20	1	0	0	0	0	0
Calcium oxide CaO			20	0	0	0	0	0	0
Calcium sulphate CaSO <sub>4</sub>	mo		20	1	0	0	0	0	0
	mo		bp	1	0	0	0	0	0

Medium / Medium				Edelstahl / Stainless steel				Werkstoffe / M	
Bezeichnung / Designation	Aggregatzustand Aggregate state	Konzentration Concentration	Temperatur Temperature	unlegierte/ niedriglegierte Stähle Non/low-alloy steels	Ferritischen Stähle Ferritic steels	Austenitischen Stähle Austenitic steels	Austenitischen + Mo-Stähle Austenitic + Mo steels	/ Alloy	Alloy 600 / Alloy
Chemische Formel / Chemical Formula		%	°C						
Calcium sulphite CaSO <sub>3</sub>	hy	cs		0	0	0	0		
	hy	sa		0	0	0	0		
Carbolic acid C <sub>6</sub> H <sub>5</sub> (OH)			20	0	0	0	0	0	1
	hy	90	bp	3	3	3	0		
Carbon dioxide	dr	100	<540	0	1	0	0	0	0



Beständigkeitstabelle

Resistance tables

CO <sub>2</sub>	dr	100	1000	3					3						0	
	mo	20	25	1	1	0	0	0	0	0	0	0	0	0	0	3
	mo	100	25	3	1	0	0	0	1	0	0	1	1	0	0	3
<b>Carbon monoxide</b>		100	20	0	0	0	0	0	0	0	0	0	0	0	0	0
CO		100	<540	3	0	0	0	0	3	0	1	3	0	0	1	
<b>Carbon tetrachloride</b>	dr		20	0	0	0	0	0	0	0	0	0	0	0	0	0
CCl <sub>4</sub>	dr		bp	1	0	0	0	0	0	0	0	0	0	0	0	3
	mo		25	1	1	1	1	0	0	0	0	0	0	0	0	3
	mo		bp	3			1									3
<b>Carbonic acid see carbon dioxide</b>																
<b>Caustic-soda solution see sodium hydroxide</b>																
<b>Chilean nitrate see sodium nitrate</b>																
<b>Chloral</b>			20								0				0	3
CCl <sub>3</sub> -CHO																
<b>Chloramine</b>				3	3	1	0	0		0	0	0				
<b>Choric acid</b>	hy		20	3	3	3	3	0			0			0	0	3
HClO <sub>3</sub>																
<b>Chlorianted lime see calcium hypochlorite</b>																
<b>Chlorine</b>	dr	100	200	0	0	0	0		0	0	0	0	0	1	0	0
Cl <sub>2</sub>	dr	100	300	3	3	3	0		0	0	0	0				
	dr	100	400	3	3	3	3		0	0	0	0				
	mo		20	3	3	3	3	0			0			0	0	3
	mo		150	3	3	3	3				0			0	0	3
<b>Chlorine dioxide</b>	hy	0,5	20	3	3	3	3				1			0	0	
ClO <sub>2</sub>																
<b>Chloroacetic acid</b>		all	20	3	3	3	P	3		1	1	3		0	0	3
CH <sub>2</sub> -Cl-COOH	hy	30	80	3	3	3	3		3		0		1	0	0	3
<b>Chlorbenzene</b>	dr			0	0	0	0				0					
C <sub>6</sub> H <sub>5</sub> Cl	mo	100	20	0	P	P	P	0	0	0	0	0	1	0	0	1
<b>Chloroethane</b>				0	S	S	S	0	0	0	1	0	0		0	1
C <sub>2</sub> H <sub>5</sub> Cl																
<b>Chloroform</b>	dr			1	1	1	1	0	0	0	0	0	0	0	0	0
CHCl <sub>3</sub>	mo			3	P	P	P	0	0	0		0		0	0	3
<b>Chloronaphtaline</b>				0	0	0	0	0	0	0	0	0		0	0	0
C <sub>10</sub> H <sub>7</sub> Cl																
<b>Chlorophenol</b>				1	0	0	0				0					
C <sub>6</sub> H <sub>4</sub> (OH)Cl																
<b>Chlorophonic acid</b>	dr	100	20	0	0	0	0	0	0	0	0	0	0	0	0	0
HSO <sub>3</sub> Cl	mo		20	3	3	3	1	1	1	1			3	3	0	3
<b>Chrome alum</b>	hy	1	20	3	3	0	0					1		0		1
KCr(SO <sub>4</sub> ) <sub>2</sub>	cs			3	3	1	0		0			0	1	0		3
	sa			3	3	3	3		0			1	3	0		3



Beständigkeitstabelle

Resistance tables

Medium / Medium				Edelstahl / Stainless steel				Werkstoffe / M	
Bezeichnung / Designation	Aggregatzustand Aggregate state	Konzentration Concentration	Temperatur Temperature	unlegierte/ niedriglegierte Stähle Non/low-alloy steels	Ferritischen Stähle Ferritic steels	Austenitischen Stähle Austenitic steels	Austenitischen + Mo-Stähle Austenitic + Mo steels	/ Alloy	2.4816 Alloy 600 / Alloy
Chemische Formel / Chemical Formula		%	°C						
<b>Chromic acid</b> H <sub>2</sub> CrO <sub>4</sub>	hy	5	20	3	3	0	0	1	3
	hy	5	90	3	3	3	3		
	hy	10	20	3	0	0	0	1	3
	hy	10	65	3	3	3	3		
	hy	10	bp	3	3	3	3	1	3
	hy	50	bp	3	3	3	3	3	3
	hy	60	20	3	3	3	3	1	3
<b>Chromic-acid anhydride</b> see chromium oxide									
<b>Chromium oxide</b> CrO <sub>3</sub>				0	0	0	0	0	0
<b>Chromium sulphate</b>  Cr <sub>2</sub> (SO <sub>4</sub> ) <sub>3</sub>	cs			3	0	0	0		0
	sa			3	0	1	1		1
<b>Cider</b>			20	3	0	0	0	0	0
			bp	3	0	0	0	0	0
<b>Citric acid</b>  C <sub>6</sub> H <sub>8</sub> O <sub>7</sub>	hy	all	<80	3	3	0	0		0
	hy	all	bp	3	3	3	0		0
<b>Combustion gases</b> freee from S or H <sub>2</sub> SO <sub>4</sub> and Cl			<=400	0	0	0	0		
	with S or H <sub>2</sub> SO <sub>4</sub> and Cl		>adp and <=400	0	0				
						0	0		
<b>Copper (II) acetate</b>  Cu <sub>2</sub> (CH <sub>3</sub> COO) <sub>4</sub>	hy		20	3	0	0	0	0	1
	hy		bp	3	0	0	0		
<b>Copper (II) chloride</b>  CuCl <sub>2</sub>	hy	1	20	3	3	P	P	0	3
	hy	cs		3	3	3	3	3	3
<b>Copper (II) nitrate</b>  Cu(NO <sub>3</sub> ) <sub>2</sub>	hy	1	20		0	0	0	0	3
	hy	50	bp		0	0	0		3
	hy	cs			0	0	0	0	3
<b>Copper (II) sulphate</b>  CuSO <sub>4</sub>	hy	cs		3	0	0	0	0	3
	hy	sa		3	1	0	0	0	3
<b>Cresol</b>  C <sub>6</sub> H <sub>4</sub> (CH <sub>3</sub> )OH		all	20	3	1	0	0		0
		all	bp	3	1	1	0		0
<b>Crotonaldehyde</b>  CH <sub>3</sub> -CH=CH-CHO			20	3		0	0	0	0
			bp			1	0	0	0
<b>Cyclohexane</b> (CH <sub>2</sub> ) <sub>6</sub>				0	0	0	0	0	0
<b>Diammonium phosphate</b> see ammonium phosphate									





Beständigkeitstabelle

Resistance tables

<b>Dibromethane</b> CH <sub>2</sub> Br-CH <sub>2</sub> Br				1		0	0						0			3
<b>Dichlorflourmethane</b> CF <sub>2</sub> Cl <sub>2</sub>	dr		bp			0	0	0	0	0	0	0			0	0
	dr		20			0	0	0	0	0	0	0			0	0
	mo		20			0	0	0	0	0	0	0			0	0
<b>Dichloroethane</b> CH <sub>2</sub> Cl-CH <sub>2</sub> Cl	dr	100	20	0	P	P	P	1	0					0	0	0
	mo	100	20		P	P	P							0		
<b>Dichloroethylene</b> see acetylene dichloride																
<b>Diethyl ether</b> (C <sub>2</sub> H <sub>5</sub> ) <sub>2</sub> O				0	0	0	0	0	0	0	1	0	0	0	0	0
<b>Ethane</b> CH <sub>3</sub> -CH <sub>3</sub>			20	0	0	0	0	0	0	0	0	0	0	0	0	0
<b>Ether</b> see diethyl ether																
<b>Ethereal oils</b>			20	1	0	0	0	0	0	0	0	0	0	0	0	0
<b>Ethyl alcohol</b> C <sub>2</sub> H <sub>5</sub> OH		all	20	0	0	0	0	0	0	0	0	0	0	0	0	0
		all	bp	1	0	0	0	0	0	0	0	0	0	0	0	0

Medium / Medium				Werkstoffe / Materials												
Bezeichnung / Designation	Aggregatzustand / Aggregate state	Konzentration / Concentration	Temperatur / Temperature	Edelstahl / Stainless steel				Nickellegierungen / Nickel alloys			Reinmetalle / Pure metals					
Chemische Formel / Chemical Formula	%	°C		unlegierte/ niedriglegierte Stähle / Non/low-alloy steels	Ferritischen Stähle / Ferritic steels	Austenitischen Stähle / Austenitic steels	Austenitischen + Mo-Stähle / Austenitic + Mo steels	/ Alloy	Alloy 600 / 2.4816	/ Alloy	2.4610, 2.4619 / C-4, C-246	/ Alloy	Nickel / Nickel	Titan / Titanium	Tantal / Tantalum	Aluminium / Aluminium
<b>Ethylbenzene</b> C <sub>6</sub> H <sub>5</sub> -C <sub>2</sub> H <sub>5</sub>				1	0	0	0	0	0	0	0	0	0	0	0	0
<b>Ethyl chloride</b> see chloroethane																
<b>Ethylene</b> CH <sub>2</sub> =CH <sub>2</sub>			20	0	0	0	0									0
<b>Ethylene dibromide</b> see dibromethane																
<b>Ethylene dichloride</b> see dichloroethane																
<b>Ethylene glycol</b> CH <sub>2</sub> OH-CH <sub>2</sub> OH	100		20	0	0	0	0	0	1	0	0	1	1	0	0	0
<b>Exhaust gases</b> see combustion gases																
<b>Fats</b>				0	0	0	0	0	0	0	0	0	0	0	0	0
<b>Fatty acid</b> C <sub>17</sub> H <sub>33</sub> COOH	100		20	0	0	0	0	0	0	0	0	1	0	0	0	0
	100		60	3	0	0	0	0	0	0	0	0	0	0	0	1
	100		150	3	3	0	0	0	0	0	0	1	0	0	0	3
	100		180	3	3	3	0	0	0	0	0	1	0	0	0	3
	100		300	3	3	3	0	0	0	0	0		0	0	0	3
<b>Fixing salt</b> see sodium thiosulphate																



Beständigkeitstabelle

Resistance tables

<b>Flue gases</b> see combustion gases									
<b>Fluorine</b>	mo		20	3	3	3	3		
F	dr	100	20	0	0	0	0		
	dr	100	200	0	0	P	p		
	dr	100	500	3					
<b>Fluorosilicic acid</b>		100	20	3	3	P	P		
H <sub>2</sub> (SiF <sub>6</sub> )		25	20	3	3	3	3	1	1
		70	20	3	3	3	3		
	Dampf			3	3	3	3		
<b>Formaldehyde</b>	hy	10	20	3	0	0	0	0	0
CH <sub>2</sub> O	hy	40	20	3	0	0	0	0	0
	hy	all	bp	3	0	0	0		
<b>Formic acid</b>		10	20	3	3	1	0	0	1
HCOOH		10	bp	3	3	3	1	0	1
		80	bp	3	3	3	3	0	1
		85	65	3	3	3	3	0	1
<b>Fuels</b>									
Benzine			20		0	0	0	0	0
			bp		0	0	0	0	0
Benzene			20		0	0	0	0	0
			bp		0	0	0	0	0
Benzine-alcohol mixture			20		0	0	0	0	0
Diesel oil			20		0	0	0	0	0
<b>Furfural</b>		100	25	1	1	1	1		
		100	bp	3	1	1	1		
<b>Gallic acid</b>	hy	1	20	1	0	0	0		
C <sub>6</sub> H <sub>2</sub> (OH) <sub>3</sub> COOH		100	20	3	0	0	0		
		100	bp	3	0	0	0		3
<b>Gelantine</b>			20	0	0	0	0		0
			80	1	0	0	0		0
<b>Glacial acetic acid</b> see acetic acid									
<b>Glass</b>	me		1200	1		1	1		

Medium / Medium				Edelstahl / Stainless steel				Werkstoffe / M		
Bezeichnung / Designation				Edelstahl / Stainless steel				Nickellegierungen		
Chemische Formel / Chemical Formula				unlegierte/ niedriglegierte Stähle Nom/low-alloy steels	Ferritischen Stähle Ferritic steels	Austenitischen Stähle Austenitic steels	Austenitischen + Mo-Stähle Austenitic + Mo steels	/ Alloy	Alloy 600	/ Alloy
Aggregatzustand Aggregate state				Konzentration Concentration	Temperatur Temperature					
				%	°C					
<b>Glauber salt</b> see sodium sulphate										



Beständigkeitstabelle

Resistance tables

<b>Gluconic acid</b> CH <sub>2</sub> OH(CHOH) <sub>4</sub> -COOH		100	20	1	0	0	0	0	0	0	0	0	0	0	0
<b>Glucose</b> C <sub>6</sub> H <sub>12</sub> O <sub>6</sub>	hy		20		0	0	0							0	0
<b>Glutamic acid</b> HOOC-CH <sub>2</sub> -CH <sub>2</sub> -CHNH <sub>2</sub> -COOH			20	1	P	P	0	0	1	0	0	1	1		
			80	3	P	P	0		1		1				
<b>Glycerine</b> CH <sub>2</sub> OH-CHOH-CH <sub>2</sub> OH		100	20	0	0	0	0	0	0	0	0	0	0	0	0
		100	bp	1	1	0	0		0	0	0		0	0	0
<b>Glycol</b> see ethylen glycol															
<b>Glycolic acid</b> CH <sub>2</sub> OH-COOH			20	3	1	1	1				0			0	1
			bp	3	3	3	3				0			0	1
<b>Glysanitine</b> see antifreeze															
<b>Hexachlorethane</b> CCl <sub>3</sub> -CCl <sub>3</sub>			20			0	0	0	0	0	0	0		0	3
<b>Hexamethylentetramin</b> (CH <sub>2</sub> ) <sub>6</sub> N <sub>4</sub>	hy		20	60	1		0	0			0				
	hy		80	60	3		0	0			0				
<b>Household ammonia</b> see ammonium hydroxide															
<b>Hydrazene</b> N <sub>2</sub> N-NH <sub>2</sub>			20	0		0		3	3			3	3		1
<b>Hydrazine sulphate</b> (NH <sub>2</sub> ) <sub>2</sub> H <sub>2</sub> SO <sub>4</sub>	hy	10	bp	3		3	3								
<b>Hydrobromic acid</b> Aqueous solution of hydrogen bromide (HBr)			20	3	3	3	3	3	3	3	3	3		0	3
<b>Hydrochloric acid</b> HCl		0,2	20	3	3	P	P				0		P	0	0
		0,5	20	3	3	3	P				0			0	0
		0,5	bp	3	3	3	3				3			1	0
		1	20	3	3	3	P	3	3		0	1	1	0	0
		2	65	3	3	3	3				0			0	0
		5	20	3	3	3	3	3	3		0	1	3		3
		15	20	3	3	3	3	3	3		0	3	3	3	0
		32	20	3	3	3	3				0			3	0
		32	bp	3	3	3	3				3			3	0
<b>Hydrochloric acid gas</b> see hydrogen chloride															
<b>Hydrofluoric acid</b> HF		10	20	3	3	3	3	1	1	0	0	1	1	3	3
		50	20	1				1	1	1	1	1	1	3	3
		80	bp								1	1		3	3
		90	30					1	1			0	1	3	3
<b>Hydrogen</b>			<300	0		0	0				0				0



Beständigkeitstabelle

Resistance tables

H			>300	3		0	0		
Hydrogen bromide	dr	100	20	0	0	0	0		
HBr	mo	30	20	3	3	3	3		
Hydrogen chloride	dr		20	0	3	1	1	0	0
HCl	dr		100	0	3	3	3	0	0
	dr		250	1	3	3	3	0	0
	dr		500	3	3	3	3		1
Hydrogen cyanide	dr		20	3	0	0	0	0	1
HCN	hy	20	20	3	1	0	0	0	1
	hy	cs	20	3	1	0	0	0	0
Hydrogen fluoride		5	20		3	3	3	3	0
HF		100	500	3	3	3	3	3	3

Medium / Medium				Edelstahl / Stainless steel				Werkstoffe / M		
Bezeichnung / Designation		Aggregatzustand Aggregate state	Konzentration Concentration	Temperatur Temperature	unlegierte/ niedriglegierte Stähle Non/low-alloy steels	Ferritischen Stähle Ferritic steels	Austenitischen Stähle Austenitic steels	Austenitischen + Mo-Stähle Austenitic + Mo steels	/ Alloy	Alloy 600 2.4816
Chemische Formel / Chemical Formula			%	°C						/ Alloy
Hydrogen peroxide			all	20	3	3	0	0	0	1
H <sub>2</sub> O <sub>2</sub>										
Hydrogen sulphide		dr	100	20	1	S	0	0	0	1
H <sub>2</sub> S		dr	100	100	3	S	0	0		
		dr	100	200	3	3	0	0		
		mo		20	3	3	0	0		0
Hydroiodic acid		dr		20	0	0	0	0		
		mo		20	3	3	3	3		
Hypochlorous acid				20	3	3	3	3		
HOCl										
Indol				20	0	0	0	0	0	0
Ink see gallic acid										
Iodine		dr	100	20	0	P	P	P		
J <sub>2</sub>		mo		20	3	3	3	3		
		mo		bp	3	3	3	3		
Iodoform		dr		60	0	0	0	0		
CH <sub>3</sub> I		mo		20	3	3	P	P		
Iron (II) chloride		hy	10	20	0		P	P		
FeCl <sub>2</sub>		hy	cs						3	3
Iron (III) chloride		dr	100	20	0	P	P	P	1	3
FeCl <sub>3</sub>		hy	5	25	3	3	3	3	3	3
		hy	10	65	3	1	1	1		
		hy	50	20	3	3	3	3		3
Iron (III) nitrate		hy	10	20	3	0	0	0		



Beständigkeitstabelle

Resistance tables

Fe(NO <sub>3</sub> ) <sub>3</sub>	hy	all	bp	3	0	0	0	3	3	3	3	3	0		
<b>Iron (II) sulphate</b> FeSO <sub>4</sub>	hy	all	bp	0	0	0	0				0	0	3	0	3
<b>Iron (III) sulphate</b> Fe(SO <sub>4</sub> ) <sub>3</sub>	hy	<30	20	3	0	0	0	0	3		0	1	3	0	0
<b>Isatine</b> C <sub>8</sub> H <sub>5</sub> NO <sub>2</sub>	hy	all	bp	3	1	0	0				0			0	0
<b>Kalinite</b> see alum			20	1	0	0	0	0	0	0	0	0	0	0	0
<b>Ketene</b> R <sub>2</sub> C=C=O			20		0	0	0	0	0	0	0		0	0	0
<b>Lactic acid</b> C <sub>3</sub> H <sub>6</sub> O <sub>3</sub>	hy	1	20	3	3	0	0	0		0	0			0	0
	hy	all	20	3	3	1	0				0			0	0
	hy	10	SP	3	3	3	3	0	3		0	3	3	0	0
	hy	all	SP	3	3	3	1				0			0	0
<b>Lactose</b> C <sub>12</sub> H <sub>22</sub> O <sub>11</sub>	hy		20	0	0	0	0	0	0	0	0	0	0	0	0
<b>Lead</b> Pb	me		388	3	1	1	1		0			3		0	0
			900	3	3	3	3				0				
<b>Lead acetate</b> (CH <sub>3</sub> -COO) <sub>2</sub> Pb	me			3	0	0	0				0	0			3
<b>Lead acide</b> Pb(N <sub>3</sub> ) <sub>2</sub>		<20	<30					0	0	0		1	1		
<b>Lead nitrate</b> Pb(NO <sub>3</sub> ) <sub>2</sub>	hy		100	1	0	0	0	0	0	0	0	0		0	0
<b>Lime</b> see calcium oxide															
<b>Lithium</b> Li	me		300	0	0	0	0	0	0	0	0	3		0	3
<b>Lithium chloride LiCl</b>	hy	cs		3	3	3	L	0	0	0	0	1	0	0	

Medium / Medium

Werkstoffe / Materials

Bezeichnung / Designation	Medium / Medium			Edelstahl / Stainless steel				Nickellegierungen / Nickel alloys				Reinmetalle / Pure metals				
	Aggregatzustand Aggregate state	Konzentration Concentration	Temperatur Temperature	unlegierte/ niedriglegierte Stähle Non/low-alloy steels	Ferritischen Stähle Ferritic steels	Austenitischen Stähle Austenitic steels	Austenitischen + Mo-Stähle Austenitic + Mo steels	/ Alloy	2.4816 Alloy 600	/ Alloy	2.4610, 2.4619 C-4, C-246	/ Alloy	Nickel Nickel	Titan Titanium	Tantal Tantalum	Aluminium Aluminium
<b>Lithium hydroxide</b> LiOH	hy	all	20	1	0	0	0	0	0	0	0	0	0	0	0	0
<b>Magnesium</b> Mg	me		650		1	3	3	3	3	3	3	3	3	0	0	3
<b>Magnesium carbonate</b> MgCO <sub>3</sub>	hy		20	0	0	0	0	0	0	0	0	0	0	0	0	1
	hy		bp	0	0		0	0	0	0	0	0	0	0	0	1
<b>Magnesium chloride</b> MgCl <sub>2</sub>	hy	5	20	3	3	P	P	0	0	0	0	0	0	0	0	3
	hy	5	bp	3	3	3	3	0	0	0	0	0	0	0	0	3
	hy	50	bp	3	3	3	3	0	0	0	0	0	0	0	0	3
<b>Magnesium hydroxide</b>	hy	cs		0		0	0	0	0	0	0	0	0	0	0	3



Beständigkeitstabelle

Resistance tables

Mg(OH) <sub>2</sub>	hy	sa		0		0	0	0	0
<b>Magnesium nitrate</b> Mg(NO <sub>3</sub> ) <sub>2</sub>		cs		0	0	0	0	3	3
<b>Magnesium oxide MgO</b> see magnesium hydroxide									
<b>Magnesium sulphate</b> MgSO <sub>4</sub>	hy	0,1	20	0	1	0	0		
	hy	5	20	3	1	0	0	0	1
	hy	50	bp	3	1	0	0		
<b>Maleic acid</b> HOOC-HC=CHCOOH	hy	5	20	3	0	0	0	0	1
	hy	50	100	3	0	0	0		1
<b>Maleic anhydride</b>		100	285						
<b>Mallic acid</b>	hy		20	3	3	0	0	0	1
	hy	50	100	3	3	0	0	0	1
<b>Malonic acid</b> CH <sub>2</sub> (COOH) <sub>2</sub>			20			1	1	1	1
			50					1	1
			100					3	3
<b>Manganese (II)-chloride</b> MnCl <sub>2</sub>	hy	5	100	3	P	P	P	1	1
	hy	50	20	1	3	P	P	1	1
<b>Manganese (II)-sulphate</b> MnSO <sub>4</sub>		cs		0	0	0	0	0	0
<b>Maritime climate</b>	mo			2P	1P	1P	0	0	0
<b>Menthol</b> C <sub>10</sub> H <sub>19</sub> OH					0	0	0	0	0
<b>Mercury</b> Hg	dr	100	20	0	P	P	P		0
		all	<500	1	1	1	0		0
<b>Methane</b> CH <sub>4</sub>			200	0	0	0	0	0	0
			600						
<b>Methanol</b> see methyl alcohol									
<b>Methyl acetate</b> CH <sub>3</sub> COOCH <sub>3</sub>		60	20	0		0	0		
		60	bp	0		0	0		
<b>Methyl alcohol</b> CH <sub>3</sub> OH		<100	20		0	0	0	0	0
		100	bp	1	3	1	1		0
<b>Methylamine</b> CH <sub>3</sub> -NH <sub>2</sub>	hy	25	20	1	0	0	0	0	
<b>Methyl chloride</b> CH <sub>3</sub> Cl	dr	100	20	0	0	0	0		0
	mo		20	3	P	P	P		0
	mo		100		P	P	P		0
<b>Methyldehyde</b> see formaldehyde									
<b>Methylen dichloride</b> CH <sub>2</sub> Cl <sub>2</sub>	dr		20	0	P	P	P		
	mo		20		P	P	P	0	
	mo		bp		P	P	P	1	



Beständigkeitstabelle

Resistance tables

Milk of lime				20	0	1	0	0												0
Ca(OH) <sub>2</sub>				bp	0	1	0	0												0

Medium / Medium				Edelstahl / Stainless steel				Werkstoffe / Materials				Reinmetalle / Pure metals					
Bezeichnung / Designation		Aggregatzustand / Aggregate state	Konzentration / Concentration	Temperatur / Temperature	unlegierte / niedriglegierte Stähle / Non/low-alloy steels	Ferritischen Stähle / Ferritic steels	Austenitischen Stähle / Austenitic steels	Austenitischen + Mo-Stähle / Austenitic + Mo steels	/ Alloy	Alloy 600	/ Alloy	2,4610, 2,4619 C-4, C-246	/ Alloy	Nickel / Nickel	Titan / Titanium	Tantal / Tantalum	Aluminium / Aluminium
Chemische Formel / Chemical Formula			%	°C													
<b>Milk suger</b> see lactose																	
<b>Mixed acids</b>																	
HNO <sub>3</sub>	H <sub>2</sub> SO <sub>4</sub>																
%	%																
90	10			20	0		0	0	1			3	3	0			1
50	50			20			0	30						0			3
50	50			20			0	0									
50	50			60			1	0									
50	60			120		3	3	1	3								
38	75			50		3	0	00									
25	75			50		3	1	0									
25	75			50		3	1	00									
25	75			90		3	3	00									
15	20	H <sub>2</sub> O		157		3	3	0									
15	20	%		20		3	0	1									
15	70	-		80		3	1	1									
10	70	-		50		3	0										
10	30	-		90	3	3	1										
5	30	-		20		3	0										
5	30	2		90		3	0										
5	15	-		bp		3	3										
5	-	-		134		3	1										
	-	-				3											
	65	-				3											
	65	-				3											
	20	-				3											
	20	-															
	65	-															
	65	-															
	65	-															
	80	-															
<b>Molasses</b>							0	0	0	0	0	0	0	0	0	0	0
<b>Monochloroacetic acid</b> see chloroacetic acid																	
<b>Naphtaline</b>			100	20	0	0	0	0						0			1
C <sub>10</sub> H <sub>8</sub>			100	390	0	0	0	0									
<b>Naphtaline chloride</b>			100	45								0					
			100	200								0					
<b>Naphtaline-sulphonic acid</b>			100	20	0		0	0				0					
C <sub>10</sub> H <sub>7</sub> SO <sub>2</sub> H			100	bp		3	3	3				0					
<b>Naphtenic acid</b>			100	20		P	P	P	0	0	0	0	1				0
<b>Nickel (II) chloride</b>		hy	10	20	3	P	P	PP	0	1	0	0	1	1	00		
NiCl <sub>2</sub>		hy	10	bp	3	3	P	0				0					
			sa	70								1					
<b>Nickel (II) nitrate</b>		hy	10	25	3	0	0	0	0	0	0	0	3	0	0	0	3
Ni(NO <sub>3</sub> ) <sub>2</sub>		hy	<100	25	3	0	0	0	0	3	1	3	3	0	0	0	3
<b>Nickel (II) sulphate</b>		hy		20	3	0	0	00	0	1	1	1	3	00			
NiSO <sub>4</sub>		hy		bp	3	0	0		0	0	1	1	3				



Beständigkeitstabelle

Resistance tables

Nitric acid HNO <sub>3</sub>		1	20	3	0	0	0 0 0			
		1	bp	3	0	0	0 0			
		5	20	3	0	0	0			
		5	bp	3	1	0	0	0	3	
		10	bp	3	1	0	1 0			
		15	bp	3	1	0	3 3 3			
		25	bp	3	3	0	3			
		50	bp	3	3	3				
		65	20	3	0	0		0		
		65	bp	3	3	3			3	
		99	bp	3	3	3		0	0	
		20	290	3	3	3		0	3	
		40	200	3	3	3			3	
Nitrobenzene C <sub>6</sub> H <sub>5</sub> (NO <sub>2</sub> ) <sub>y</sub>				0	0	0	0	0	0	0
Nitrobenzoic acid C <sub>6</sub> H <sub>4</sub> (NO <sub>2</sub> )COOH	hy		20	1	0	0	0	0	0	0
Nitroglycerine C <sub>3</sub> H <sub>5</sub> (ONO <sub>2</sub> ) <sub>3</sub>			20	0	0	0	0			

Medium / Medium				Edelstahl / Stainless steel				Werkstoffe / M	
Bezeichnung / Designation	Aggregatzustand / Aggregate state	Konzentration / Concentration	Temperatur / Temperature	unlegierte / niedriglegierte Stähle / Non/low-alloy steels	Ferritischen Stähle / Ferritic steels	Austenitischen Stähle / Austenitic steels	Austenitischen + Mo-Stähle / Austenitic + Mo steels	/ Alloy	2.4816 Alloy 600 / Alloy
Chemische Formel / Chemical Formula		%	°C						
Nitrogen N		100	20	0		0	0		0
Nitrous acid HNO <sub>2</sub> similar to nitric acid		100	900	1					
Oleic acid see fatty acid									
Oleum see sulfur trioxide									
Oxalic acid C <sub>2</sub> H <sub>2</sub> O <sub>4</sub>	hy	all	20	3	3	0	0	1	1
	hy	10	bp	3	3	3	3	0	1
	hy	sa		3	3	3	3	1	1
Oxygen O			500	1	0	0	0		
Ozone					0	0	0	0	0
Paraffin C <sub>n</sub> H <sub>2n+2</sub>	me		20	0	0	0	0		
			120	0	0	0	0		
Perchloroethylene C <sub>2</sub> Cl <sub>4</sub>			20	0	0	0	0		
			bp	0	1	1	1		





Beständigkeitstabelle

Resistance tables

Bezeichnung / Designation	Medium / Medium			Edelstahl / Stainless steel				Nickellegierungen / Nickel alloys				Reinmetalle / Pure metals				
	Aggregatzustand / Aggregate state	Konzentration / Concentration	Temperatur / Temperature	unlegierte/ niedriglegierte Stähle / Non/low-alloy steels	Ferritischen Stähle / Ferritic steels	Austenitischen Stähle / Austenitic steels	Austenitischen + Mo-Stähle / Austenitic + Mo steels	/ Alloy	2.4816 Alloy 600	/ Alloy	2.4610, 2.4619 C-4, C-246	/ Alloy	Nickel / Nickel	Titan / Titanium	Tantal / Tantalum	Aluminium / Aluminium
Chemische Formel / Chemical Formula	%	°C														
Perchloroethane see hexachlorethane	mo			3	P	P	P									
Perchloric acid (60%)		10	20	3	3	3	3							0		3
HClO <sub>4</sub>		100	20	3	3	3	3							0		
Perhydrol see hydrogen superoxide																
Petroleum			20	0	0	0	0		0	0	0	0	0	0	0	0
			bp	0	0	0	0		0	0	0	0	3	0	0	0
Petrol see benzene																
Phenol see carbolic acid																
Phloroglucinol			20		0	0	0	0	0	0	0	0		0	0	0
H <sub>6</sub> H <sub>3</sub> (OH) <sub>3</sub>																
Phosgene	dr		20		0	0	0	0	0	0	0	0		0	0	0
COCl <sub>2</sub>																
Phosphoric acid	hy	1	20	3	0	0	0	0	0	0	0	1	0	0	0	3
H <sub>3</sub> PO <sub>4</sub>	hy	10	20	3	3	0	0				0			0	0	
	hy	30	bp	3	3	1	1			1	1		3	3	0	3
	hy	60	bp	3	3	3	3			1				3	0	
	hy	80	20	3	3	1	0	0	0	0				3	0	
	hy	80	bp	3	3	3	3	0	0	3			3	3	0	
Phosphorous P	dr		20	0	0	0	0									
Phosphorous pentachlorite	dr	100	20	0	0	0				0			1			
PCl <sub>5</sub>																
Phtalic acid and phtalic anhydride			20	0		0	0			0	0	0				0
			200		0	3	0			0	0	0				
C <sub>6</sub> H <sub>4</sub> (COOH) <sub>2</sub>	dr		bp			0	0	0							0	0
Picric acid	hy	3	20	3	0	0	0							0		1
C <sub>6</sub> H <sub>2</sub> (OH)(NO <sub>2</sub> ) <sub>3</sub>	hy	cs		3	0	0	0	3	3	0	3	3	3	0		0
	me		150	3	0	0	0							0		3
Plaster see calcium sulphate																
Potash lye see potassium hydroxide																



Beständigkeitstabelle

Resistance tables

<b>Potassium</b>	me		604	0		0	0		
K			80			0	0		
<b>Potassium acetate</b>	me	100	292	1		0	0		
CH <sub>3</sub> -COOK	hy		20	1	0	0	0		0
<b>Potassium bisulphate</b>	hy	5	20	3	3	2	0		
KHSO <sub>4</sub>	hy	5	90	3	3	3	3		
<b>Potassium bitartrate</b>	hy	cs		3	3	0	0		
KC <sub>4</sub> H <sub>5</sub> O <sub>6</sub>	hy	sa		3	3	3	1		
<b>Potassium bromide</b>	hy	5	30	3	P	P	P	0	1
KBr									
<b>Potassium carbonate</b>	hy	50	20	1	0	0	0	0	0
K <sub>2</sub> CO <sub>3</sub>	hy	50	bp	3	3	0	0	0	0
<b>Potassium chlorate</b>	hy	5	20	3	0	0	0	0	1
KClO <sub>3</sub>	hy	sa		3	0	0	0	0	3
<b>Potassium chloride</b>	hy	10	20	3	3	P	P	0	0
KCl	hy	10	<bp	3	3	P	P		
	hy	30	bp	3	3	P	P		
	hy	cs		3	P	P	P		
	hy	sa		3	3	P	P		
<b>Potassium chromate</b>	hy	10	20	0		0	0	0	0
K <sub>2</sub> CrO <sub>4</sub>	hy	10	bp	1		0	0		
<b>Potassium cyanide</b>	hy	10	20	3	0	0	0	0	3
KCN	hy	10	bp	3	0	0	0		
<b>Potassium dichromate</b>	hy	10	40	3	0	0	0	1	1
K <sub>2</sub> Cr <sub>2</sub> O <sub>7</sub>	hy	25	40	3	3	0	0	1	1
	hy	25	bp	3	3	0	0		
<b>Potassium ferricyanide</b>	hy	1	20	0	0	0	1	1	0
K <sub>3</sub> (Fe(CN) <sub>6</sub> )	hy	cs			0	0	0		0
	hy	sa		3	0	P	0		0
<b>Potassium ferrocyanide</b>	hy	1	20		0	0	0	1	1
K <sub>4</sub> (Fe(CN) <sub>6</sub> )	hy	25	20		0	0	0	0	0
	hy	25	bp		1	1	0	0	0
<b>Potassium fluoride</b>	hy	cs		0	0	0	0		
KF	hy	sa		1	0	0	0		
<b>Potassium hydroxide</b>	hy	10	20		0	S	S	1	1
	hy	20	bp		0	S	S	1	1
	hy	30	bp		3	S	S	1	3
	hy	50	20	S	0	S	S	1	1
	hy	50	bp	S	3	3	3	1	3
	hy	sa		S	3	S	S		
	me	100	360	S	3	3	3		3
<b>Potassium hypochlorite</b>	hy	all	20		P	P	P	3	3
KClO	hy	all	bp		P	P	P	3	3
<b>Potassium iodide</b>	hy		20	0	P	P	P	0	1
KJ	hy		bp	0	3	P	P	0	1
<b>Potassium nitrate</b>	hy	all	20		0	0	0	0	1

**Beständigkeitstabelle**

**Resistance tables**

KNO <sub>3</sub>	hy	all	bp		0	0	0				1			0		1
<b>Potassium nitrite</b> KNO <sub>2</sub>		all	bp	1	0	0	0	1	0	0	0	0	1			
<b>Potassium permanganate</b> KMnO <sub>4</sub>	hy	10	20	0	0	0	0				0	1	0	0	0	0
<b>Potassium persulphate</b> K <sub>2</sub> S <sub>2</sub> O <sub>8</sub>	hy	all	bp	3	1	1	1	0	1	1	1	1	0	0	0	0
<b>Potassium silicate</b> K <sub>2</sub> SiO <sub>3</sub>		10	50	3	3	0	0		0		0	3	3	0		3
<b>Potassium sulphate</b> K <sub>2</sub> SO <sub>4</sub>	hy		20	1	0	0	0	0	0	0	0	0	0	0		3
	hy	10	25	3	0	0	0	0	0	0	0	0	1	0	0	0
	hy	all	bp	0	0	0	0	0	0	0	0	0	0	0	0	1

Medium / Medium				Edelstahl / Stainless steel				Werkstoffe / Materials					Reinmetalle / Pure metals				
Bezeichnung / Designation		Aggregatzustand / Aggregate state	Konzentration / Concentration	Temperatur / Temperature	unlegierte/ niedriglegierte Stähle / Non/low-alloy steels	Ferritischen Stähle / Ferritic steels	Austenitischen Stähle / Austenitic steels	Austenitischen + Mo-Stähle / Austenitic + Mo steels	Nickellegierungen / Nickel alloys		2.4610, 2.4619 / C-4, C-246		Titan / Titanium		Aluminium / Aluminium		
Chemische Formel / Chemical Formula			%	°C					/ Alloy	Alloy 600	/ Alloy	/ Alloy	Nickel / Nickel	Titan / Titanium	Tantal / Tantalum	Aluminium / Aluminium	
<b>Propionic acid</b> see acetic acid																	
<b>Protein solutions</b>				20	1	0	0	0	0	0	0	0	0	0	0	0	
<b>Prussic acid</b> see hydrogen cyanide																	
<b>Pyridine</b> C <sub>5</sub> H <sub>5</sub> N		dr		20		0	0	0						0		0	
			all	bp		0	0	0		0	0	0	0	0	0	0	
<b>Pyrogallol</b> C <sub>6</sub> H <sub>3</sub> (OH) <sub>3</sub>			all	20	3	0	0	0						0		0	
			all	bp	3	0	0	0				1		0		0	
<b>Quinine bisulphate</b>		dr		20	3	3	3	0	0		0	0	1	0	0		
<b>Quinine sulphate</b>		dr		20	3	0	0	0	0		0	0	1	0	0		
<b>Quinol</b> HO-C <sub>6</sub> H <sub>4</sub> -OH					3		0	0	0	0	0		1	1		0	
<b>Salicytic acid</b> HOC <sub>6</sub> H <sub>4</sub> COOH		dr	100	20	1	0	0	0	0	1	0	0	1	1	0	0	
		mo	100	20	3		0	0				1	0	0		0	
		hy	cs		3		0	0	0	1	0	0	0	0		1	
<b>Salmiac</b> see ammonium chloride																	
<b>Salpetre</b> see potassium nitrate																	
<b>Seawater</b> at flow velocity v (m/s): 0 < v ≤ 1,5									0		0						
				20	1	P	P	P		P		0	P	P			
				20	1	0	0	0	0	0	0	0	0	1			
<b>Siliceous flux acid</b> see fluorsilicic acid																	
<b>Silver nitrate</b>		hy	10	20	3	0	0	0	0	1	1	1	3	3	0	0	3



Beständigkeitstabelle

Resistance tables

AgNO <sub>3</sub>	hy	10	bp	3	0	0	0		
	hy	20	60	3	0	0	0		
	hy	40	20	3	0	0	0		
	me	100	250	3	3	0	0		
<b>Soap</b>	hy	1	20	0	0	0	0		0
	hy	1	75	0	0	0	0		
	hy	10	20	0	0	0	0		
<b>Sodium (O<sub>2</sub>£0,005%)</b>			200	0	0	0	0		
Na	me		600	3	1	0	0		
<b>Sodium acetate</b>	hy	10	25	0	0	0	0		0
CH <sub>3</sub> -COONa	hy	sa		3	0	0	0		
<b>Sodium aluminate</b>		100	20	0	0	0	0		
Na <sub>2</sub> AlO <sub>3</sub>	hy	10	25	0	0	0	0		
<b>Sodium arsenate</b>	hy	cs		0	0	0	0		
Na <sub>2</sub> HAsO <sub>4</sub>									
<b>Sodium bicarbonate</b>		100	20		0	0	0		
NaHCO <sub>3</sub>	hy	10	20	0	0	0	0	0	1
	hy	cs			0	0	0	0	1
	hy	sa			0	0	0		
<b>Sodium bisulphate</b>	hy	all	20	3	3	3	0	0	1
NaHSO <sub>4</sub>	hy	all	bp	3	3	3	1	0	1
<b>Sodium bisulphite</b>	hy	10	20	3	3	0	0		
NaHSO <sub>3</sub>	hy	50	20	3	0	0	0		
	hy	50	bp	3	3	3	0		
<b>Sodium borate</b>	hy	cs			0	0	0	0	
Na <sub>2</sub> B <sub>4</sub> O <sub>7</sub>	me			3	3	3	3		
<b>Sodium bromide</b>	hy	all	20	3	3	3	P		
NaBr	hy	all	bp	3	3	3	P		

Medium / Medium				Edelstahl / Stainless steel				Werkstoffe / M			
Bezeichnung / Designation		Aggregatzustand / Aggregate state	Konzentration / Concentration	Temperatur / Temperature	unlegierte/ niedriglegierte Stähle / Non/low-alloy steels	Ferritischen Stähle / Ferritic steels	Austenitischen Stähle / Austenitic steels	Austenitischen + Mo-Stähle / Austenitic + Mo steels	/ Alloy	Alloy 600	/ Alloy
Chemische Formel / Chemical Formula			%	°C						2.4816	
<b>Sodium carbonate</b>		hy	1	20	3	0	0	0	0	1	
Na <sub>2</sub> CO <sub>3</sub>		hy	all	bp		0	0	0	0	0	
		hy		400	3	3	3	3			
		me		900	3	3	3	3			
<b>Sodium chloride</b>		hy	0,5	20		P	P	P	0	1	
NaCl		hy	2	20		P	P	P	0	1	



Beständigkeitstabelle

Resistance tables

	hy	cs		3	P	P	P	0	1	0	0	0	1	0	0	2
	hy	sa		3	3	3	P	0	1	0	1	0	1	0	0	3
<b>Sodium chlorite</b>	dr	100	20	3	P	P	0		0					0		
NaClO <sub>2</sub>	hy	5	20			3	P							0		
	hy	5	bp			3	3				1			0		
	hy	10	80	3		3	P		0		1			0		
<b>Sodium chromate</b>	hy	all	bp	0	0	0	0	0	0	0	0	0				0
Na <sub>2</sub> CrO <sub>4</sub>																
<b>Sodium cyanide</b>	me		600	1								3				3
NaCN	hy	cs		1	0	0	0					3	0	0		3
<b>Sodium fluoride</b>	hy	10	20	0		0	0									0
NaF	hy	10	bp	0		0	0									
<b>Sodium hydrogensulfit</b> see sodium bisulphate																
<b>Sodium hydrogensulphate</b> see sodium bisulphate																
<b>Sodium hydroxide</b>	solid	100	all	0	0	0	0		0	0	0	0	0			
NaOH	hy	<10	<60	0	0	0	0		0	0	0	0	0			
	hy	<10	<bp	3	3	0	0		0	0	0	0	0			
	hy	<20	<60	0	0	0	0		0	0	0	0	0			
	hy	<20	<bp	3	3	0	0		0	0	0	0	0			
	hy	<40	<60	0	0	0	0		0	0	0	0	0			
	hy	<40	<100	3	3	0	0		0	0	0	0	0			
	hy	<40	>100	3	3	3	3		0	0	0	0	0			
	hy	<50	<60	0	0	0	0		0	0	0	0	0			
	hy	<50	<100	3	3	0	0		0	0	0	0	0			
	hy	<50	>100	3	3	3	3		0	0	0	0	0			
	hy	<60	<90	3	3	0	0		0	0	0	0	0			
	hy	<60	<140	3	3	3	3		0	0	0	0	0			
	hy	<60	>140	3	3	3	3		3	0	3	0	0			
<b>Sodium hypochloride</b>	hy	5	20	3	3	3	P	0	3		0	3	3	0		3
NaOCl	hy	10	50	3		P	P		0		1			0		3
<b>Sodium hyposulphite</b>		all	20		3	0	0	0	1	1	1	1	1		0	
Na <sub>2</sub> S <sub>2</sub> O <sub>4</sub>		all	bp		3	0	0	0	1	1	1	1	1		0	
<b>Sodium iodide</b>							P	P	P	0	0	0	0			1
NaJ																
<b>Sodium nitrate</b>	hy	5	20	3	0	0	0	0	0	0	0	1	1	0	0	0
NaNO <sub>3</sub>	hy	10	20	1	0	0	0	0	0	0	1	1	1	0	0	0



Beständigkeitstabelle

Resistance tables

	hy	<10	bp	3	0	0	0		
	hy	30	20	1	0	0	0	0	0
	hy	30	bp	1	0	0	0	0	0
	me		320	3	0	0	0		
<b>Sodium nitrite</b> Na <sub>2</sub> O <sub>2</sub>	hy		20			0	0	1	0
<b>Sodium perborate</b> NaBO <sub>2</sub>	hy	10	20	3	0	0	0		
	hy	10	bp	3	0	0	0		
<b>Sodium perchlorate</b> NaClO <sub>4</sub>	hy	10	20	3	3	0	0	1	
	hy	10	bp	3		0	0	1	
<b>Sodium peroxide</b> Na <sub>2</sub> O <sub>2</sub>	hy	10	20	3	1	0	0	1	1
	hy	10	bp	3	3	0	0	1	1
	me		460					3	1

Medium / Medium				Edelstahl / Stainless steel				Werks	
Bezeichnung / Designation		Aggregatzustand / Aggregate state	Konzentration / Concentration	Temperatur / Temperature	unlegierter/ niedriglegierte Stähle / Non/low-alloy steels	Ferritischen Stähle / Ferritic steels	Austenitischen Stähle / Austenitic steels	Austenitischen + Mo-Stähle / Austenitic + Mo steels	/ Alloy
Chemische Formel / Chemical Formula		%	°C						
<b>Sodium phosphate</b> Na <sub>2</sub> HPO <sub>4</sub>	hy	10	20			0	0	0	0
	hy	10	bp			0	0	0	0
	hy	cs				0	0	0	0
<b>Sodium salicylate</b> C <sub>6</sub> H <sub>4</sub> (OH)COONa	hy	all	20			0	0	0	0
<b>Sodium silicofluoride</b> Na <sub>2</sub> (SiF <sub>6</sub> )	hy	cs			3	3	3	3	0
<b>Sodium sulphate</b> Na <sub>2</sub> SO <sub>4</sub>	hy	10	20		3	0	0	0	0
	hy	cs			3	1	0	0	0
	hy	sa			3	3	0	0	0
<b>Sodium sulphide</b> Na <sub>2</sub> S	hy	1	20		3	0	0	0	0
	hy	cs	20		3	3	3	0	0
	hy	sa			3	3	3	1	
<b>Sodium sulphite</b> Na <sub>2</sub> SO <sub>3</sub>	hy	10	20		3	1	0	0	
	hy	50	bp		3	3	0	0	
<b>Sodium superoxide</b> see sodium peroxide									
<b>Sodium tetraborat</b> see borax									
<b>Sodium thiosulphate</b> Na <sub>2</sub> S <sub>2</sub> O <sub>3</sub>	hy	1	20		1	0	0	0	
	hy	10	20		3	0	0	0	
	hy	25	bp		3	P	P	P	
		cs			3	3	0	0	
<b>Spirit of turpentine</b>		100	20		3	0	0	0	
		100	bp		3	0	0	0	

## Beständigkeitstabelle

## Resistance tables

<b>Spirits</b>			20	1	0	0	0	0
			bp	3	0	0	0	0
<b>Steam</b>								
O <sub>2</sub> < 1 ppm; Cl < 10 ppm			<560	1	1	1	0	
O <sub>2</sub> < 1 ppm; Cl < 10 ppm			<315	S	S	S	S	
O <sub>2</sub> < 15 ppm; Cl < 3 ppm			>450	S	S	S	S	
<b>Stearic acid</b>								
CH <sub>3</sub> (CH <sub>2</sub> ) <sub>16</sub> COOH		100	20	1	0	0	0	
		100	95	3	0	0	0	0
		100	180					
<b>Succinic acid</b>								
HOOC-CH <sub>2</sub> -COOH			bp	1	0	0	0	0
<b>Sulphur</b>	dr	100	60	0	0	0	0	
S	me		130	1	0	0	0	
	me		240	3	0	0	0	
	mo		20	3	2	1	0	
<b>Sulphur dioxide</b>	dr	100	20	0	0	0	0	0
SO <sub>2</sub>	dr	100	60	3	3	1	1	
	dr	100	400	3	3	3	0	
	dr	100	800	3	3	3	3	
	mo	100	20	3	3	3	0	0
	mo	100	60	3	3	3	0	
	mo	100	60	3	3	3	0	
	mo	100	70	3	3	3	3	



Medium / Medium				Edelstahl / Stainless steel				Werkstoffe / M	
Bezeichnung / Designation	Aggregatzustand / Aggregate state	Konzentration / Concentration	Temperatur / Temperature	unlegierter / niedriglegierte Stähle / Non/low-alloy steels	Ferritischen Stähle / Ferritic steels	Austenitischen Stähle / Austenitic steels	Austenitischen + Mo-Stähle / Austenitic + Mo steels	/ Alloy	2.4816 Alloy 600 / Alloy
Chemische Formel / Chemical Formula		%	°C						
<b>Sulphuric acid</b>		0,05	20	3	1	0	0		
H <sub>2</sub> SO <sub>4</sub>		0,05	bp	3	1	1	0		
		0,1	20	3	3	0	0		
		0,2	bp	3	3	3	0		
		0,8	bp	3	3	3	3		
		1	20	3	3	1	0		1
		3	bp	3	3	3	3		
		5	bp	3	3	3	3	1	3
		7,5	20	3	3	1	0		
		10	bp	3	3	3	3	1	3
		25	20	3	3	3	3		
		25	bp	3	3	3	3		
		40	20	3	3	3	3		
		40	bp	3	3	3	3		
		50	20	3	3	3	3	1	3
		50	bp	3	3	3	3	3	3
		60	20	3	3	3	3		
		80	20	3	3	1	1		
		90	20	3	3	1	0		
		96	20	1	1	1	0		
<b>Sulphurous acid</b>	hy	1	20	3	3	0	0		1
H <sub>2</sub> SO <sub>3</sub>	hy	cs		3	3	0	0		
	hy	sa		3	3	1	0		
<b>Tannic acid</b>	hy	5	20	3	0	0	0		0
C <sub>76</sub> H <sub>52</sub> O <sub>46</sub>	hy	25	100	3	3	0	0		
	hy	50	bp	3	3	0	0		
<b>Tar</b>			20	0	0	0	0		
<b>Tartaric acid</b>	hy	10	20	1	0	0	0	0	1
	hy	10	bp	3	1	0	0	0	3
	hy	25	20	3	1	0	0		0
	hy	25	bp	3	3	1	0		0
	hy	50	20	3	3	0	0		
	hy	50	bp	3	3	3	3		
<b>Tetrachloroethane see acetylen tetrachloride</b>									
<b>Tetrachloroethylen</b>	pure	100	20	0	0	0	0		
CHCl=CCl <sub>2</sub>	pure	100	bp			0	0		
	mo		20	3	3	P	P		
	mo		bp	3	3	P	P		
<b>Tin chloride</b>		5	20	3	3	3	3	3	3





Beständigkeitstabelle

Resistance tables

SnCl <sub>2</sub> :SnCl <sub>4</sub>		sa		3	3	3	3										
<b>Toluene</b>		100	20	0	0	0	0					0		0			0
C <sub>6</sub> H <sub>5</sub> -CH <sub>3</sub>		100	bp	0	0	0	0					0		0			0
<b>Town gas</b>				0	0	0	0	0	0	0	0	0	1	1			
<b>Trichloroacetaldehyde</b> see chloral																	
<b>Trichloroacetic acid</b> see chloroacetic acid																	
<b>Trichloroethylene</b>	pure	100	20	0	0	0	0					0		0	0		0
CHCl=CCl <sub>2</sub>	pure	100	bp				0	0				0		0	0		0
	mo		20	3	3	P	P					0		0	0		3
	mo		bp	3	3	P	P					0		0	0		3
<b>Trichloromethane</b> see chloroform																	
<b>Tricresylphosphate</b>				0	0	0	0	0	0	0	0						
<b>Trinitrophenol</b> see picric acid																	

Medium / Medium

Werkstoffe / Materials

Bezeichnung / Designation				Edelstahl / Stainless steel				Nickellegierungen / Nickel alloys				Reinmetalle / Pure metals				
Chemische Formel / Chemical Formula	Aggregatzustand Aggregate state	Konzentration Concentration	Temperatur Temperature	unlegierte/ niedriglegierte Stähle Non/low-alloy steels	Ferritischen Stähle Ferritic steels	Austenitischen Stähle Austenitic steels	Austenitischen + Mo-Stähle Austenitic + Mo steels	/ Alloy		/ Alloy		Nickel Nickel	Titan Titanium	Tantal Tantalum	Aluminium Aluminium	
								2.4816	Alloy 600	2.4610, 2.4619 C-4, C-276	/ Alloy					
<b>Urea</b>		100	20	0	0	0	0					0	0	0	0	0
CO(NH <sub>2</sub> ) <sub>2</sub>		100	150	3		1	0	3				1	1	1	0	3
<b>Uric acid</b>	hy		20	3	0	0	0	0	1	0	0	0	0	0	0	3
C <sub>5</sub> H <sub>4</sub> O <sub>4</sub> N <sub>3</sub>	hy		100	3	0	0	0	0	1	0	0	0	0	0	0	3
<b>Vinyl chloride</b>	dr		20	0	0	0	0					0				0
CH <sub>2</sub> =CHCl			<400	0	0	0	0					0		0		
<b>Water vapour</b> see steam																
<b>Wine</b>			20	3	0	0	0	0				3		0		3
			bp	3	0	0	0	0				3		0		3
<b>Yeast</b>			20	1	0	0	0	0	0	0	0	0	0	0	0	0
<b>Yellow potassium prussiate</b> see potassium ferricyanide																
<b>Zinc chloride</b>	hy	5	20	3	P	P	P	0	1	0	0	1	1	0	0	3
ZnCl <sub>2</sub>	hy	5	bp	3	3	3	3	0	3		1	3	1	0	0	3
	hy	10	20	3	P	P	P					3	0	0	0	0
	hy	20	20	3	P	P	P							0	0	
	hy	75	20	3	3	P	P							0	0	
<b>Zinc sulphate</b>	hy	2	20	3	0	0	0					0		0	0	0
ZnSO <sub>4</sub>	hy	20	bp	3	0	0	0					1		0	0	3
	hy	30	bp	3	3	0	0					1		0	0	3
	hy	cs		3	0	0	0	0	1	0	1	1	1	0	0	1

**Beständigkeitstabelle**

**Resistance tables**

	hy	sa		3	3	0	0				1			0	0	3
--	----	----	--	---	---	---	---	--	--	--	---	--	--	---	---	---



Flanschanschluss-Maße

Flange connection dimensions

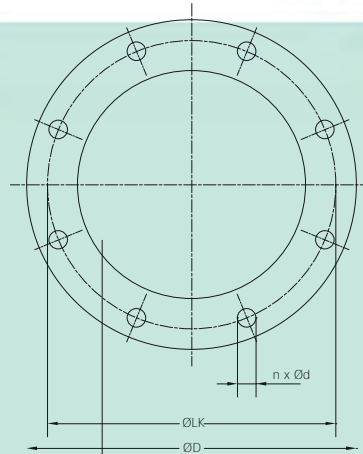

Flanschtabelle

Flange table

DN	Zoll	N 6 n				PN 1				PN 1				PN 2			
		ØD mm	ØLK mm	n	Ød mm	ØD mm	ØLK mm	n	Ød mm	ØD mm	ØLK mm	n	Ød mm	ØD mm	ØLK mm	n	Ød mm
20		90	65	4	11	105	75	4	14	105	75	4	14	105	75	4	
25	1	100	75	4	11	115	85	4	14	115	85	4	14	115	85	4	
32	1 ¼	120	90	4	14	140	100	4	18	140	100	4	18	140	100	4	
40	1 ½	130	100	4	14	150	110	4	18	150	110	4	18	150	110	4	
50	2	140	110	4	14	165	125	4	18	165	125	4	18	165	125	4	
65	2 ½	160	130	4	14	185	145	8	18	185	145	8	18	185	145	8	
80	3	190	150	4	18	200	160	8	18	200	160	8	18	200	160	8	
100	4	210	170	4	18	220	180	8	18	220	180	8	18	235	190	8	
125	5	240	200	8	18	250	210	8	18	250	210	8	18	270	220	8	
150	6	265	225	8	18	285	240	8	22	285	240	8	22	300	250	8	
175	7	295	255	8	18	315	270	8	22	315	270	8	22	330	280	12	
200	8	320	280	8	18	340	295	8	22	340	295	12	22	360	310	12	
250	10	375	335	12	18	395	350	12	22	405	355	12	26	425	370	12	
300	12	440	395	12	22	445	400	12	22	460	410	12	26	485	430	16	
350	14	490	445	12	22	505	460	16	22	520	470	16	26	555	490	16	
400	16	540	495	16	22	565	515	16	26	580	525	16	30	620	550	16	
450	18	595	550	16	22	615	565	20	26	640	585	20	30	670	600	20	
500	20	645	600	20	22	670	620	20	26	715	650	20	33	730	660	20	
600	24	755	705	20	26	780	725	20	30	840	770	20	36	845	770	20	
700	28	860	810	24	26	895	840	24	30	910	840	24	36	960	875	24	
800	32	975	920	24	30	1015	950	24	33	1025	950	24	39	1085	990	24	

## Flanschanschluss-Maße

### Flange connection dimensions

900	36	1075	1020	24	30	1115	1050	28	33	1125	1050	28	39	1185	1090	28
1000	40	1175	1120	28	30	1230	1160	28	36	1255	1170	28	42	1320	1210	28
1200	48	1405	1340	32	33	1455	1380	32	39	1485	1390	32	48	-	-	-
1300	52	1520	1450	32	36	1565	1485	32	42	1585	1490	36	48	-	-	-
1400	56	1630	1560	36	36	1675	1590	36	42	1685	1590	36	48	-	-	-
1500	60	1730	1660	36	36	1795	1705	36	48	1810	1705	36	56	-	-	-
1600	-	1830	1760	40	36	1915	1820	40	48	1930	1820	40	56	-	-	-
1700	-	1940	1865	40	39	2015	1920	44	48	2030	1920	44	56	-	-	-
1800	72	2045	1970	44	39	2115	2020	44	48	2130	2020	44	56	-	-	-
1900	-	2155	2075	44	42	2220	2125	48	48	2240	2125	44	62	-	-	-
2000	-	2265	2180	48	42	2325	2230	48	48	2345	2230	48	62	-	-	-
2100	84	2375	2285	48	42	2440	2335	48	56	-	-	-	-	-	-	-
2200	-	2475	2390	52	42	2550	2440	52	56	2555	2440	52	62	-	-	-
2400	96	2685	2600	56	42	2760	2650	56	56	2765	2650	56	62	-	-	-
2500	-	2795	2705	56	48	2860	2750	56	56	2865	2750	60	62	-	-	-
2600	-	2905	2810	60	48	2960	2850	60	56	2965	2850	60	62	-	-	-
2800	-	3115	3020	64	48	3180	3070	64	56	-	-	-	-	-	-	-
3000	120	3315	3220	68	48	3405	3290	68	62	-	-	-	-	-	-	-
3200	-	3525	3430	72	48	-	-	-	-	-	-	-	-	-	-	-
3400	-	3735	3640	76	48	-	-	-	-	-	-	-	-	-	-	-
3600	144	3970	3860	80	56	-	-	-	-	-	-	-	-	-	-	-
3800	-	-	-	-	-	-	-	-	-	-	-	-	-	-	-	-
4000	-	-	-	-	-	-	-	-	-	-	-	-	-	-	-	-

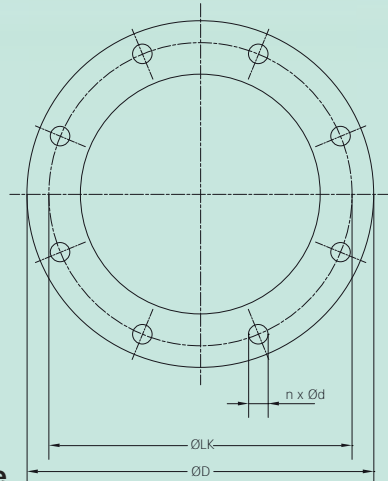

**Flanschanschluss-Maße**

**Flange connection dimensions**

**Flanschtabelle**

**Flange table**

DN	Zoll	16.5-150 lbs				Serie A 150 I				A C207 Class D			
		ØD mm	ØLK mm	n ASME B	Ød mm	ØD mm	ØLK mm	n ASME B 16.47	Ød mm	bs	ØD mm	ØLK mm	n AWW
20	3/4	-	-	-	-	-	-	-	-	-	-	-	-
25	1	108,0	79,2	4	15,7	-	-	-	-	-	-	-	-
32	1 1/4	117,0	89,0	4	15,7	-	-	-	-	-	-	-	-
40	1 1/2	127,0	98,4	4	15,7	-	-	-	-	-	-	-	-
50	2	152,4	120,6	4	19,0	-	-	-	-	-	-	-	-
65	2 1/2	177,8	139,7	4	19,0	-	-	-	-	-	-	-	-
80	3	190,5	152,4	4	19,0	-	-	-	-	-	-	-	-
100	4	228,6	190,5	8	19,0	-	-	-	-	-	-	-	-
125	5	254,0	215,9	8	22,2	-	-	-	-	-	-	-	-
150	6	279,4	241,3	8	22,2	-	-	-	-	-	-	-	-
-	7	311,2	269,9	8	22,2	-	-	-	-	-	-	-	-
200	8	342,9	298,4	8	22,2	-	-	-	-	-	-	-	-
250	10	406,4	361,9	12	25,4	-	-	-	-	-	-	-	-
300	12	482,6	431,8	12	25,4	-	-	-	-	482,6	431,8	12	25
350	14	533,4	476,2	12	28,6	-	-	-	-	533,4	476,3	12	28
400	16	596,9	539,7	16	28,6	-	-	-	-	596,9	539,8	16	28
450	18	635,0	577,8	16	31,8	-	-	-	-	635,0	577,9	16	31
500	20	698,5	635,0	20	31,8	-	-	-	-	698,5	635,0	20	31
550	22	749,3	692,2	20	34,9	-	-	-	-	749,3	692,2	20	34
600	24	812,8	749,3	20	34,9	-	-	-	-	812,8	749,3	20	34
650	26	-	-	-	-	870,0	806,4	24	34,9	870,0	806,4	24	34

## Flanschanschluss-Maße

### Flange connection dimensions

700	28	-	-	-	-	927,1	863,6	28	34,9	927,1	863,6	28	34
750	30	-	-	-	-	984,3	914,4	28	34,9	984,3	914,4	28	34
800	32	-	-	-	-	1060,5	977,9	28	41,3	1060,5	977,9	28	41
850	34	-	-	-	-	1111,3	1028,7	32	41,3	1111,3	1028,7	32	41
900	36	-	-	-	-	1168,4	1085,8	32	41,3	1168,4	1085,9	32	41
950	38	-	-	-	-	1238,3	1149,4	32	41,3	1238,3	1149,4	32	41
1000	40	-	-	-	-	1289,1	1200,2	36	41,3	1289,1	1200,2	36	41
1050	42	-	-	-	-	1346,2	1257,3	36	41,3	1346,2	1257,3	36	41
1100	44	-	-	-	-	1403,4	1314,5	40	41,3	1403,4	1314,5	40	41
1150	46	-	-	-	-	1454,2	1365,3	40	41,3	1454,2	1365,3	40	41
1200	48	-	-	-	-	1511,3	1422,4	44	41,3	1511,3	1422,4	44	41
1250	50	-	-	-	-	1568,5	1479,6	44	47,6	1568,5	1479,6	44	47
1300	52	-	-	-	-	1625,6	1536,7	44	47,6	1625,6	1536,7	44	47
1350	54	-	-	-	-	1682,7	1593,8	44	47,6	1682,7	1593,8	44	47
1400	56	-	-	-	-	1746,3	1651,0	48	47,6	1746,3	1651,0	48	47
1450	58	-	-	-	-	1803,4	1708,2	48	47,6	1803,4	1708,2	48	47
1500	60	-	-	-	-	1854,2	1758,9	52	47,6	1854,2	1759,0	52	47
1650	66	-	-	-	-	-	-	-	-	2032,0	1930,4	52	47
1800	72	-	-	-	-	-	-	-	-	2197,1	2095,5	60	47
1950	78	-	-	-	-	-	-	-	-	2362,2	2260,6	64	54
2100	84	-	-	-	-	-	-	-	-	2533,7	2425,7	64	54
2250	90	-	-	-	-	-	-	-	-	2705,1	2590,8	68	61
2400	96	-	-	-	-	-	-	-	-	2876,5	2755,9	68	61
2550	102	-	-	-	-	-	-	-	-	3048,0	2908,3	72	68
2700	108	-	-	-	-	-	-	-	-	3219,5	3067,1	72	68
2850	114	-	-	-	-	-	-	-	-	3390,9	3219,5	76	74
3000	120	-	-	-	-	-	-	-	-	3562,4	3371,9	76	74
3150	126	-	-	-	-	-	-	-	-	3734,0	3537,0	80	81
3300	132	-	-	-	-	-	-	-	-	3905,0	3702,0	80	81
3450	138	-	-	-	-	-	-	-	-	4077,0	3861,0	84	87

# Flanschanschluss-Maße

## Flange connection dimensions

3600	144	-	-	-	-	-	-	-	-	4248,0	4020,0	84	87
------	-----	---	---	---	---	---	---	---	---	--------	--------	----	----

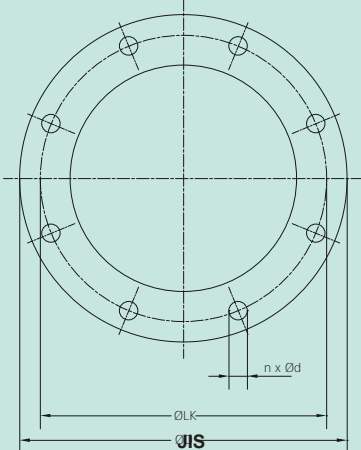

Flanschtabelle

Flange table JIS B

DN	Zoll	B 2220 5K				2220 10K n				DIN 86044 n			
		ØD mm	ØLK mm	n	Ød mm	ØD mm	ØLK mm	Ød mm	ØD mm	ØLK mm	Ød mm		
20	3/4	85	65	4	12	100	75	4	15	-	-	-	-
25	1	95	75	4	12	125	90	4	19	-	-	-	-
32	1 ¼	115	90	4	15	135	100	4	19	-	-	-	-
40	1 ½	120	95	4	15	140	105	4	19	150	110	4	-
50	2	130	105	4	15	155	120	4	19	165	125	4	-
65	2 ½	155	130	4	15	175	140	4	19	185	145	8	-
80	3	180	145	4	19	185	150	8	19	200	160	8	-
90	-	190	155	4	19	195	160	8	19	-	-	-	-
100	4	200	165	8	19	210	175	8	19	220	180	8	-
125	5	235	200	8	19	250	210	8	23	250	210	8	-
150	6	265	230	8	19	280	240	8	23	285	240	8	-
-	7	300	260	8	23	305	265	12	23	-	-	-	-
200	8	320	280	8	23	330	290	12	23	320	280	8	-
250	10	385	345	12	23	400	355	12	25	375	335	12	-
300	12	430	390	12	23	445	400	16	25	440	395	12	-
350	14	480	435	12	25	490	445	16	25	490	445	12	-
400	16	540	495	16	25	560	510	16	27	540	495	16	-
450	18	605	555	16	25	620	565	20	27	595	550	16	-
500	20	655	605	20	25	675	620	20	27	645	600	20	-

## Flanschanschluss-Maße

### Flange connection dimensions

550	22	720	665	20	27	745	680	20	33	703	650	20
600	24	770	715	20	27	795	730	24	33	754	700	20
650	26	825	770	24	27	845	780	24	33	805	750	20
700	28	875	820	24	27	905	840	24	33	856	600	24
750	30	945	880	24	33	970	900	24	33	907	850	24
800	32	995	930	24	33	1020	950	28	33	958	900	24
850	34	1045	980	24	33	1070	1000	28	33	1010	950	28
900	36	1095	1030	24	33	1120	1050	28	33	1060	1010	28
950	38	-	-	-	-	-	-	-	-	1110	1060	28
1000	40	1195	1130	28	33	1235	1160	28	39	1166	1110	32
1050	42	-	-	-	-	-	-	-	-	-	-	-
1100	44	1305	1240	28	33	1345	1270	28	39	1266	1210	32
1150	46	-	-	-	-	-	-	-	-	-	-	-
1200	48	1420	1350	32	33	1465	1380	32	39	1366	1310	36
1250	50	-	-	-	-	-	-	-	-	-	-	-
1300	52	-	-	-	-	-	-	-	-	1466	1410	40
1350	54	1575	1505	32	33	1630	1540	36	45	-	-	-
1400	56	-	-	-	-	-	-	-	-	1566	1510	40
1450	58	-	-	-	-	-	-	-	-	-	-	-
1500	60	1730	1660	36	33	1795	1700	40	45	1666	1610	44
1600	64	-	-	-	-	-	-	-	-	1766	1710	48
1700	68	-	-	-	-	-	-	-	-	1866	1810	48
1800	72	-	-	-	-	-	-	-	-	1966	1910	52
1900	76	-	-	-	-	-	-	-	-	2066	2010	56
2000	80	-	-	-	-	-	-	-	-	2166	2110	56
2100	84	-	-	-	-	-	-	-	-	2266	2210	60
2200	88	-	-	-	-	-	-	-	-	2366	2310	64
2300	92	-	-	-	-	-	-	-	-	2466	2410	64
2400	96	-	-	-	-	-	-	-	-	2566	2510	68



## Flanschanschluss-Maße

### Flange connection dimensions

2500	100	-	-	-	-	-	-	-	-	-	2666	2610	72
2600	104	-	-	-	-	-	-	-	-	-	2766	2710	72
2700	108	-	-	-	-	-	-	-	-	-	2866	2810	75